



The Signature of Quality

FEDERAL INDUSTRIES

A Standex Company
215 Federal Avenue
Belleville, WI 53508-9201

Phone: 800-356-4206
Fax: 608-424-3234
Email: geninfo@federalind.com
Website: www.federalind.com

Project Name: _____

Item #: _____

Model #: _____ Qty: _____

Approval: _____

AIA#

SIS#

CURVED GLASS NON-REFRIGERATED BAKERY CASE

Sleek curved-glass styling blends with traditional design elements to maximize performance. Designed for continuous case line-ups without middle end glass.



MODEL	DIMENSIONS (Includes End Panels)
<input type="checkbox"/> CGD3148	31.13 x 35.31 x 48 (in) 791 x 897 x 1219 (mm)
<input type="checkbox"/> CGD3642	36.13 x 35.31 x 42 (in) 918 x 897 x 1067 (mm)
<input type="checkbox"/> CGD3648	36.13 x 35.31 x 48 (in) 918 x 897 x 1219 (mm)
<input type="checkbox"/> CGD5042	50.13 x 35.31 x 42 (in) 1273 x 897 x 1067 (mm)
<input type="checkbox"/> CGD5048	50.13 x 35.31 x 48 (in) 1273 x 897 x 1219 (mm)
<input type="checkbox"/> CGD5942	59.13 x 35.31 x 42 (in) 1502 x 897 x 1067 (mm)
<input type="checkbox"/> CGD5948	59.13 x 35.31 x 48 (in) 1502 x 897 x 1219 (mm)
<input type="checkbox"/> CGD7742	77.13 x 35.31 x 42 (in) 1959 x 897 x 1067 (mm)
<input type="checkbox"/> CGD7748	77.13 x 35.31 x 48 (in) 1959 x 897 x 1219 (mm)

STANDARD FEATURES

Model Features

- Curved glass styling.
- Tempered tilt-out front glass for easy cleaning. Front glass is curved for high visual product display.
- Tempered glass ends and doors.
- Removable sliding rear doors, shelf lights, shelf supports, and shelves.
- 31" and 36" have two swing doors.
- Steel base construction with a choice of six standard laminates on base. Other finishes optional.
- Scratch-resistant, corrosion-proof white vented display deck.
- Designed for continuous line-ups.
- Black trim.
- Adjustable Leg Levelers

Shelving

- Adjustable white wire shelves. Shelves are adjustable up and down and can also be tilted in three positions. 48" models have three tiers of shelves; 42" models have two tiers of shelves.

Lighting

- 3500K LED top light and shelf lights.
- DLC Certified, IP66 rated

Agency Approvals

- UL Safety and UL Sanitation listed
- DOE 2017 Compliant.

OPTIONAL ACCESSORIES

- Special Base Finish
- Rear Wrapping Board
- Cord & Plug (NEMA 5-15P)
- Fan Kit
- Glass, Black, Gold, or Chrome Shelves
- Reflective Ends
- White or Mirrored Interior
Ends with Laminated Exterior
- Reflective Rear Doors
- Casters (Cord & Plug Included)
- Top Cutting Board, White
- Package Shelf
- Light Below Package Shelf
- Front Glass & Rear Door Locks
- Joining Kit for Continuous Line-ups
- Hot Display Packages
- Legs

WARRANTY*

One year Parts and Labor
2nd thru 5th year part
only service compressor
(U.S.A and Canada)



Note: Information is subject to change at any time.
Visit www.federalind.com for the most current specs.

AIA#

CURVED GLASS NON-REFRIGERATED BAKERY CASE

SIS#

Product Specifications

DIMENSION: xx"/(mm)

DIMENSION TOLERANCE +/- 0.25 (6.4)

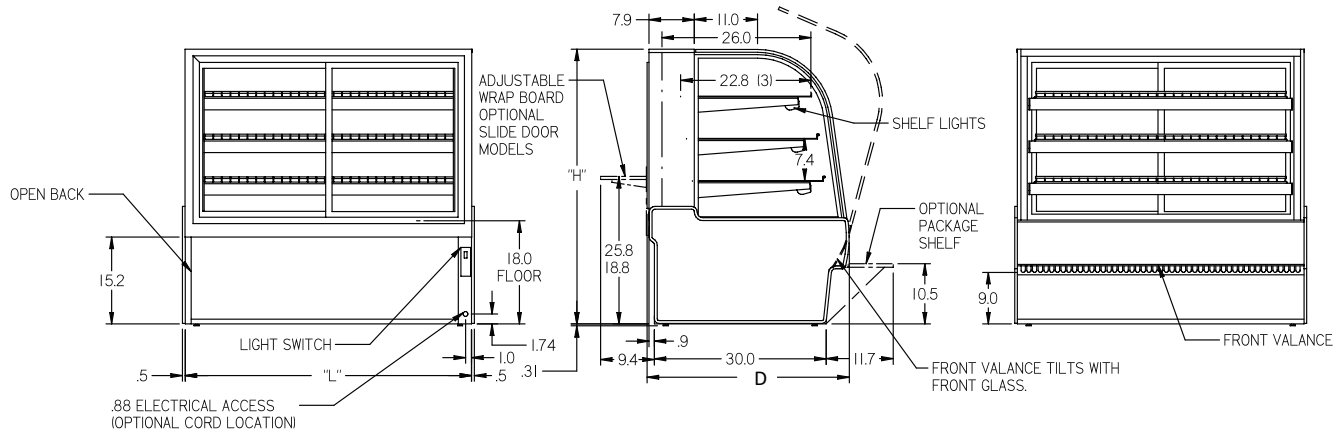

MODEL	DIMENSIONS				CAPACITY (BAKERY PAN)	REMOTE 120/60/1
	L	D	H1	UNITS		
CGD3148	31.13	35.31	48	in.	4 (18" X 26") & 4 (9" X 26")	1.5 AMPS
	791	897	1219	mm.		
CGD3642	36.13	35.31	42	in.	3 (18" X 26") & 3 (9" X 26")	1.5 AMPS
	918	897	1067	mm.		
CGD3648	36.13	35.31	48	in.	4 (18" X 26") & 4 (9" X 26")	1.5 AMPS
	918	897	1219	mm.		
CGD5042	50.13	35.31	42	in.	6 (18" X 26") & 3 (9" X 26")	1.5 AMPS
	1273	897	1067	mm.		
CGD5048	50.13	35.31	48	in.	8 (18" X 26") & 4 (9" X 26")	1.5 AMPS
	1273	897	1219	mm.		
CGD5942	59.13	35.31	42	in.	9 (18" X 26")	1.5 AMPS
	1502	897	1067	mm.		
CGD5948	59.13	35.31	48	in.	12 (18" X 26")	1.5 AMPS
	1502	897	1219	mm.		
CGD7742	77.13	35.31	42	in.	12 (18" X 26")	1.5 AMPS
	1959	897	1067	mm.		
CGD7748	77.13	35.31	48	in.	16 (18" X 26")	1.5 AMPS
	1959	897	1219	mm.		

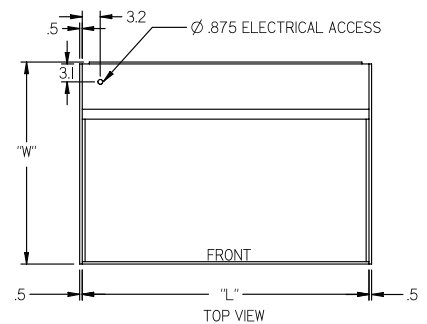

- If a GFCI circuit is required, a GFCI Breaker MUST be used instead of GFCI receptacle.
- Due to continuing engineering improvements, specifications are subject to change without notice.



The Signature of Quality®

FEDERAL INDUSTRIES

A Standex Company

215 Federal Avenue Belleville, Wisconsin 53508-9201

Phone: 800-356-4206

Fax: 608-424-3234

Email: Geninfo@Federalind.com

Website: Federalind.com