



*The Signature of Quality*

**FEDERAL INDUSTRIES**

A Standex Company  
215 Federal Avenue  
Belleville, WI 53508-9201

Phone: 800-356-4206  
Fax: 608-424-3234  
Email: geninfo@federalind.com  
Website: www.federalind.com

Project Name: \_\_\_\_\_

Item #: \_\_\_\_\_

Model #: \_\_\_\_\_ Qty: \_\_\_\_\_

Approval: \_\_\_\_\_

AIA#

SIS#

**ELEMENTS CURVED GLASS NON-REFRIGERATED BAKERY CASE**

Curved-glass styling with presentation and value in mind without sacrificing performance.



MODEL	IDE/EE ( Includes End Panels )
<input type="checkbox"/> ECGD50	50.13 x 35.31 x 48 (in) 1273 x 897 x 1219 (mm)
<input type="checkbox"/> ECGD59	59.13 x 35.31 x 48 (in) 1502 x 897 x 1219 (mm)
<input type="checkbox"/> ECGD77	77.13 x 35.31 x 48 (in) 1959 x 897 x 1219 (mm)

**STANDARD FEATURES**

**Model Features**

- Curved glass.
- Tempered thermopane tilt-out front glass.
- Tempered thermopane glass ends, sides and doors.
- Removable sliding rear doors, shelf lights, shelf supports, and shelves.
- Steel base construction, textured black powder coat finish.
- Stainless steel top and sides.
- Removable white display deck.
- Light switch and adjustable temperature control.
- Cord and plug.
- Adjustable Leg Levelers

**Shelving**

- Adjustable white wire shelves, 3 tiers, can also be tilted.

**Lighting**

- 3000K LED top light and shelf lights.
- DLC Certified, IP66 rated.

**Agency Approvals**

- UL Safety and UL Sanitation Listed.
- DOE 2017 Compliant



**WARRANTY\***  
One year Parts and Labor  
2nd thru 5th year part  
only service compressor  
(U.S.A and Canada)

Note: Information is subject to change at any time. Visit [www.federalind.com](http://www.federalind.com) for the most current specs.

AIA#

## ELEMENTS CURVED GLASS NON-REFRIGERATED BAKERY CASE

SIS#

## Product Specifications

Intended Environment: Type I - Designed to operate in maximum ambient conditions of 75°F (24°C) and 55% relative humidity unless noted otherwise in system information below.

Zone	Intended Product To Be Displayed	Avg Prod Temp °F/°C
All	Packaged Refrigerated Products	38°F / (3.3°C)

DIMENSION: xx"/(mm)

DIMENSION TOLERANCE +/- 0.19 (4.8)

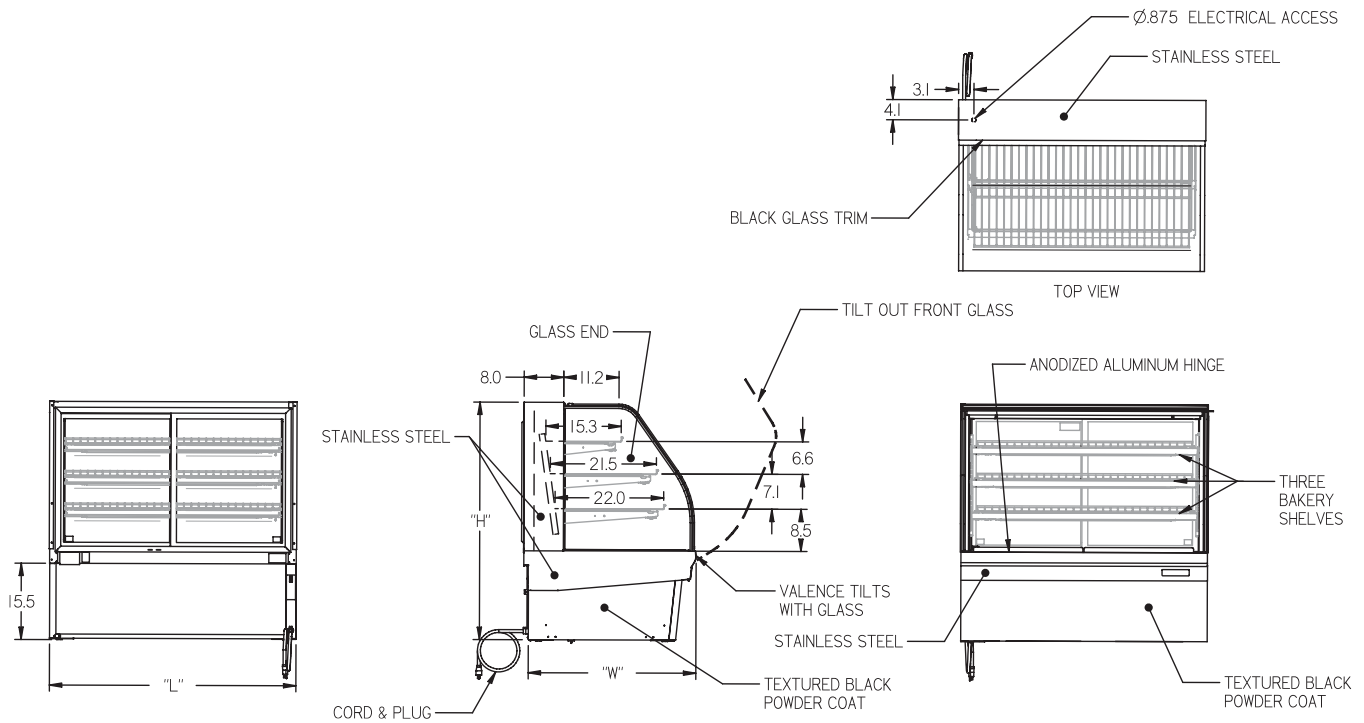

MODEL	DIMENSIONS				SHIPPING WHT		ELECTRICAL 120/60/1
	L	D	H1	UNITS	LBS	KILO	
ECGD50	50.13	35.31	48	in.	500	227	1.5 AMPS
	1273	897	1219	mm.			
ECGD59	59.13	35.31	48	in.	535	243	1.5 AMPS
	1502	897	1219	mm.			
ECGD77	77.13	35.31	48	in.	715	324	1.5 AMPS
	1959	897	1219	mm.			

- Due to continuing engineering improvements, specifications are subject to change without notice.



The Signature of Quality®

FEDERAL INDUSTRIES

A Standex Company

215 Federal Avenue Belleville, Wisconsin 53508-9201

Phone: 800-356-4206

Fax: 608-424-3234

Email: Geninfo@Federalind.com

Website: Federalind.com