



*The Signature of Quality*

### FEDERAL INDUSTRIES

A Standex Company

215 Federal Avenue  
Belleville, WI 53508-9201

Phone: 800-356-4206  
Fax: 608-424-3234  
Email: [geninfo@federalind.com](mailto:geninfo@federalind.com)  
Website: [www.federalind.com](http://www.federalind.com)

Project Name: \_\_\_\_\_

Item #: \_\_\_\_\_

Model #: \_\_\_\_\_ Qty: \_\_\_\_\_

Approval: \_\_\_\_\_

AIA#

SIS#

## Quick Ship - Under Counter Display Case (Square End, Refrigerated, Self-Serve)

Incorporate into your own counter to drive product sales. The under counter display case will entice customers with last minute impulse sales through visual appeal.

| MODEL                                | DIMENSIONS<br>( Includes End Panels )          |
|--------------------------------------|--|
| <input type="checkbox"/> UCR3633S-QS | 35.7 x 34 x 32.5 (in)<br>907 x 864 x 826 (mm)  |
| <input type="checkbox"/> UCR4833S-QS | 47.7 x 34 x 32.5 (in)<br>1212 x 864 x 826 (mm) |



UCR4833S-QS



UCR3633S-QS shown in counter, not included

### STANDARD FEATURES

#### Model Features

- Black powder coated steel base
- Black interior back panel
- Squared ends with mirrored interior
- Black top
- Black 2 step riser
- Black laminate exterior
- Light and power switch on back of case
- Front access to refrigeration system for quick and easy service
- Cord & plug
- 2.5" Recessed casters with adjustable leg lever
- Energy saving night curtain

#### Refrigeration

- On-Demand PTC condensate evaporator provided for a totally self-contained system
- Electronic temperature controls maintain 38°-40°F
- Easy clean, rustproof insulated evaporator coil compartment
- Rear condensing unit air intake & discharge
- R290 Refrigerant
- Thermometer

#### Lighting

- 3500K LED top light

#### Agency Approvals

- UL, C-UL and UL Sanitation listed to NSF-7, Type I conditions
- DOE 2017 compliant



**WARRANTY\***  
One year Parts and Labor  
2nd thru 5th year part  
only service compressor  
(U.S.A and Canada)



Note: Information is subject to change at any time.  
Visit [www.federalind.com](http://www.federalind.com) for the most current specs.

Revised 7/31/2025

# AIA# UNDER COUNTER - Quick Ship - Square End, Refrigerated, Self-Serve Display Case

## SIS# Product Specifications

Intended Environment: Type I - Designed to operate in maximum ambient conditions of 75°F (24°C) and 55% relative humidity.

| Zone | Intended Product To Be Displayed | Avg Prod Temp °F/°C |
|------|----------------------------------|---------------------|
| All  | Packaged Refrigerated Products   | 38°F / (3.3°C)      |

DIMENSION: xx"/(mm)  
DIMENSION TOLERANCE +/- 0.25 (6.4)

SYMBOL KEY:  
 ELECTRICAL JUNCTION BOX (SUPPLIED W/6" LEADS OR POWER CORD)

 TUB DRAIN LOCATION

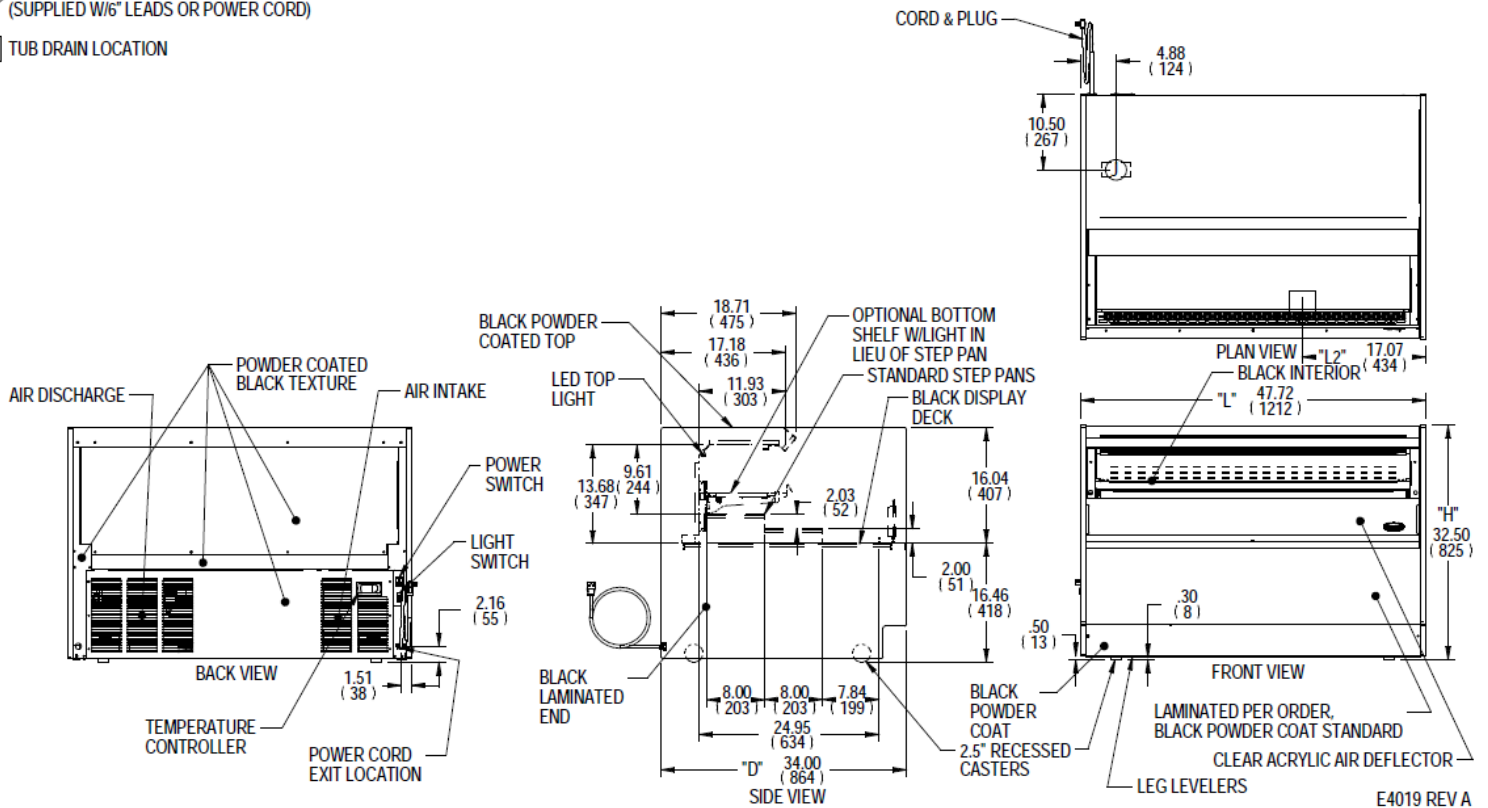

| MODEL       | DIMENSION |      |      | TUB DRAIN | STEP RISER | INTERIOR VOLUME<br>CU FT | ELECTRICAL<br>2-WIRE + GROUND | SELF CONTAINED      |               |                  | REFRIGERANT | CONDENSATE<br>REMOVAL | SHIP WEIGHT |
|-------------|-----------|------|------|-----------|------------|--------------------------|-------------------------------|---------------------|---------------|------------------|-------------|-----------------------|-------------|
|             | L         | D    | H    | L2        | # OF STEPS |                          |                               | STANDARD CONNECTION |               |                  |             |                       |             |
|             | in        | in   | in   | in        |            |                          |                               | CORD & PLUG         |               |                  |             |                       |             |
|             | mm        | mm   | mm   | mm        |            |                          |                               | AMPS                | MAX FUSE SIZE | NEMA CORD & PLUG |             |                       |             |
| UCR3633S-QS | 35.7      | 34.0 | 32.5 | 8.01      | 2          | 4.52                     | 120/60/1                      | 10.0                | 15            | 5-15             | R290        | CONDENSATE PAN        | 450 LBS     |
|             | 907       | 86   | 826  | 203       |            |                          |                               |                     |               |                  |             |                       | 203         |
| UCR4833S-QS | 47.7      | 34.0 | 32.5 | 17.01     | 2          | 6.11                     | 120/60/1                      | 10.0                | 15            | 5-15             | R290        | CONDENSATE PAN        | 605 LBS     |
|             | 1212      | 86   | 826  | 432       |            |                          |                               |                     |               |                  |             |                       | 203         |

- Case temperature will vary if the air curtain is disrupted.
- Due to continuing engineering improvements, specifications are subject to change without notice.



**FEDERAL INDUSTRIES**  
 A Standex Company  
 215 Federal Avenue Belleville, Wisconsin 53508-9201

**Phone:** 800-356-4206  
**Fax:** 608-424-3234  
**Email:** Geninfo@Federalind.com  
**Website:** Federalind.com