



The Signature of Quality

FEDERAL INDUSTRIES

A Standex Company
215 Federal Avenue
Belleville, WI 53508-9201
Phone: 800-356-4206
Fax: 608-424-3234
Email: geninfo@federalind.com
Website: www.federalind.com

Project Name: _____

Item #: _____

Model #: _____ Qty: _____

Approval: _____

AIA#

SIS#

HIGH VOLUME REFRIGERATED BAKERY CASE

Table with 2 columns: MODEL, DE/KE (Includes End Panels). Rows include SGR3142, SGR3642, SGR5042, SGR5942, SGR7742 with dimensions in inches and millimeters.

Table with 2 columns: MODEL, DE/KE (Includes End Panels). Rows include SGR3148, SGR3648, SGR5048, SGR5948, SGR7748 with dimensions in inches and millimeters.



SGR5042 Shown



SGR5948 Shown

Display more product and serve more customers with presentation and value in mind. Designed for continuous case line-ups without middle end glass.

OPTIONAL ACCESSORIES

- Special Base Finish
Special Trim
Glass Shelves
Rear Wrapping Board
Casters/Cord & Plug Included (Self-Contained Models Only)
Remote Condensing Unit (EEV Included)
Reflective Ends
White or Mirrored Interior Ends with Laminated Exterior
Reflective Rear Doors
Legs
Cord & Plug
Top Cutting Board, White
Package Shelf
Light Below Package Shelf
Black, Gold, or Chrome Wire Shelves
Front Glass and Rear Door Locks
Joining Kit for Continuous Line-ups

STANDARD FEATURES

Model Features

- Tempered thermopane tilt-out front glass for easy cleaning. Front glass is sloped for high visual product display.
Tempered thermopane glass top, ends, and doors.
Removable sliding rear doors, shelf lights, shelf supports, and shelves.
31" has a swing door, hinged right or left.
Steel base construction with a choice of six standard laminates on base. Other finishes optional.
Removable, scratch-resistant, rustproof white display deck.
Easily accessible light switch and adjustable temperature control.
Average case temperature of 38° to 40° F is maintained.
Rear access to the refrigeration system for quick and easy service.
Designed for continuous line-ups.
Black trim. Others optional
Adjustable Leg Levelers

Refrigeration

- Condensate evaporator provided for a totally self-contained system.
Oversized coil and low-velocity fan system maintains high humidity and product freshness.
Easy clean, rustproof insulated evaporator coil compartment.
Condenser air filter on self-contained units.
Thermometer.
R513a Refrigerant (R449a in Remote Applications)

Shelving

- Adjustable white wire shelves. Shelves are adjustable up and down and can also be tilted in three positions. 48" models have three tiers of shelves; 42" models have two tiers of shelves.

Lighting

- LED top light and shelf lights.

Agency Approvals

- UL Safety and UL Sanitation listed
DOE 2017 Compliant



WARRANTY*
One year Parts and Labor
2nd thru 5th year part only service compressor (U.S.A and Canada)

Note: Information is subject to change at any time. Visit www.federalind.com for the most current specs.

AIA#

HIGH VOLUME REFRIGERATED BAKERY CASE

SIS#

Product Specifications

Intended Environment: Type I - Designed to operate in maximum ambient conditions of 75°F (24°C) and 55% relative humidity unless noted otherwise in system information below.

Zone	Intended Product To Be Displayed	Avg Prod Temp °F/°C
All	Packaged Refrigerated Products	38°F / (3.3°C)

DIMENSION: xx"/(mm)

DIMENSION TOLERANCE +/- 0.25 (6.4)

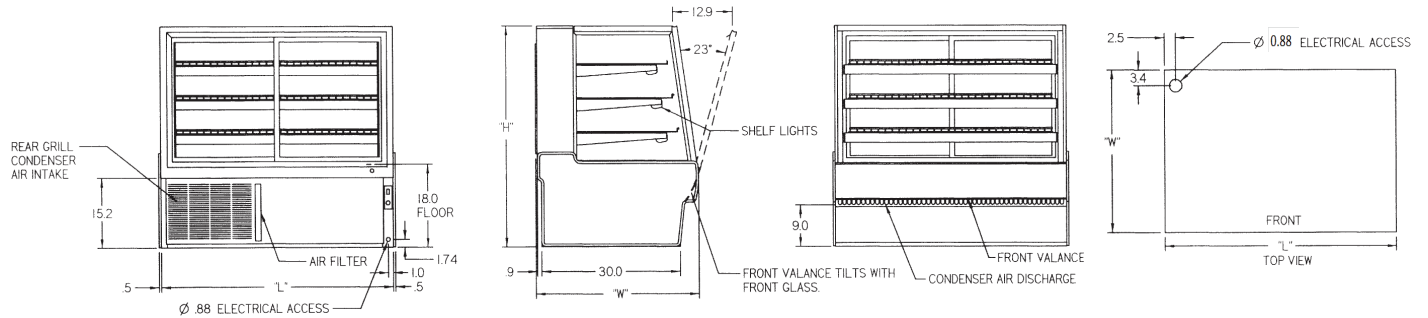

MODEL	DIMENSIONS				SHIPPING WHT		CAPACITY (BAKERY PAN)	SELF-CONTAINED 120/60/1 Permanently Connected	REMOTE 120/60/1	NEMA PLUG
	L	D	H1	UNITS	LBS	KILO				
SGR3142	31.13	35.31	42	in.	460	207	3 (18" X 26") & 3 (9" X 26")	1/3 HP - 8.0 AMPS	2.1 AMPS	5-15p
	791	897	1067	mm.						
SGR3148	31.13	35.31	48	in.	500	227	4 (18" X 26") & 4 (9" X 26")	1/3 HP - 8.0 AMPS	2.1 AMPS	5-15p
	791	897	1219	mm.						
SGR3642	36.13	35.31	42	in.	470	213	3 (18" X 26") & 3 (9" X 26")	1/3 HP - 9.0 AMPS	2.3 AMPS	5-15p
	918	897	1067	mm.						
SGR3648	36.13	35.31	48	in.	510	231	4 (18" X 26") & 4 (9" X 26")	1/3 HP - 8.0 AMPS	2.3 AMPS	5-15p
	918	897	1219	mm.						
SGR5042	50.13	35.31	42	in.	615	279	6 (18" X 26") & 3 (9" X 26")	1/2 HP - 10.5 AMPS	2.3 AMPS	5-15p
	1273	897	1067	mm.						
SGR5048	50.13	35.31	48	in.	690	313	8 (18" X 26") & 4 (9" X 26")	1/2 HP - 10.5 AMPS	2.3 AMPS	5-15p
	1273	897	1219	mm.						
SGR5942	59.13	35.31	42	in.	730	331	9 (18" X 26")	1/2 HP - 11.6 AMPS	2.5 AMPS	5-15p
	1502	897	1067	mm.						
SGR5948	59.13	35.31	48	in.	765	347	12 (18" X 26")	1/2 HP - 11.6 AMPS	2.5 AMPS	5-15p
	1502	897	1219	mm.						
SGR7742	77.13	35.31	42	in.	890	404	12 (18" X 26")	3/4 HP - 14.2 AMPS	3.3 AMPS	5-20p
	1959	897	1067	mm.						
SGR7748	77.13	35.31	48	in.	930	422	16 (18" X 26")	3/4 HP - 14.2 AMPS	3.3 AMPS	5-20p
	1959	897	1219	mm.						

- If a GFCI circuit is required, a GFCI Breaker MUST be used instead of GFCI receptacle.
- Refrigerated cases are designed to operate in a maximum of 75°F (24°C) ambient and 55% relative humidity.
- Due to continuing engineering improvements, specifications are subject to change without notice.



The Signature of Quality®

FEDERAL INDUSTRIES

A Standex Company

215 Federal Avenue Belleville, Wisconsin 53508-9201

Phone: 800-356-4206

Fax: 608-424-3234

Email: Geninfo@Federalind.com

Website: Federalind.com