



The Signature of Quality[®]

INSTALLATION & OPERATIONS INSTRUCTIONS
*Self-Contained & Remote Refrigerated Models
Including Dual Zone & Cold Deli Models
& Non-Refrigerated Displays*



KEEP THIS MANUAL FOR FUTURE REFERENCE

Engineering and technical data are subject to change without notice.

FEDERAL INDUSTRIES
215 Federal Avenue
Belleville, WI 53508

Toll Free 1(800) 356-4206
WI Phone (608) 424-3331
Fax: (608) 424-3234



CONTENTS

E1954-20	1
KEEP THIS MANUAL FOR FUTURE REFERENCE.....	1
CONTENTS	2
INTRODUCTION.....	3
SERIAL NUMBER.....	4
WARNING LABELS & SAFETY INSTRUCTIONS.....	5
REFRIGERATION WARNING.....	6
INSTALLATION-REPAIR-DECOMMISSIONING	6
WARNING	7
3. Qualification:.....	8
4. Checks to Area:	8
5. Repairs to sealed components	9
6. Detection of flammable refrigerants:.....	9
7. Removal and Evacuation:.....	9
8. Charging procedures:	10
9. Decommissioning:.....	10
10. Labeling:.....	10
11. Recovery:	10
“REFRIGERATION WARNING &INSTALLATION-REPAIR-DECOMMISSIONING”	11
Locating the Display Case.....	12
Removing Case From Shipping Skid	12
Grill Removal (Refrigerated Units).....	13
Condensate Evaporator (Refrigerated Units).....	13
Cleaning	13
Trim Kits Installation	14
Exterior Trim.....	14
Interior Trim.....	15
Refrigeration Installation (Refrigerated units)	15
Self-Contained Models.....	16
Remote Models	16
Electrical Data	17
Cord Connected.....	18
OPERATING INSTRUCTIONS.....	19
Controls (Refrigerated Units).....	19
Controls (Non-Refrigerated Units).....	19
Shelves	19
Rear Package Shelf.....	19
Sliding Rear Doors	19
Swing Rear Doors	19
Placing Product into Case.....	20
SHELVING INSTALLATION & REMOVAL	21
Shelves and shelf light quantity.....	22
SHELF INSTALLATION.....	23
Wire Shelves	23
Glass Shelves.....	23
Metal Shelves	23
LED Shelf Light Replacement	24
LED Top Light Replacement	25
PERIODIC MAINTENANCE	26
Cleaning Condenser Coil Filter (Self Contained Refrigerated Units Only)	26
Cleaning Condenser Coil (All Self Contained Refrigerated Cases)	26
CLEANING INSTRUCTIONS.....	28
Daily Cleaning.....	28
Weekly Cleaning	29
Interior Cleaning	29
Exterior Cleaning	30
SERVICE INFORMATION	31

Pre-Service Checklist	32
Case Does Not Operate	32
Lights Do Not Operate	32
Case Temperature Too Warm	32
Glass Fogging.....	32
Special Service Situations	32
Refrigerant Recovery/Recycling/Disposal	33
Owner Responsibility	33
REMOTE REFRIGERATION.....	34
Electronic Expansion Valve (EEV) On Remote Cases Only	34
MAIN WIRING DIAGRAMS	35
120 VOLT DRY.....	35
120 VOLT REFRIGERATED SELF CONTAINED	37
120 VOLT REFRIGERATED REMOTE	38
REPLACEMENT PARTS	40
SELF CONTAINED REFRIGERATION SYSTEM (REFRIGERATED CASES ONLY)	40
SELF CONTAINED REFRIGERATION SYSTEM (REFRIGERATED CASES ONLY)	40
ELECTRICAL COMPONENTS.....	41
GLASS COMPONENTS	42
DOOR & SHELF COMPONENTS	44

INTRODUCTION

Thank you for purchasing a Federal Industries display case. This manual contains important instructions for installing and servicing the Curved Glass and Hi-Volume Refrigerated (including Dual Zone & Cold Deli) and Non-Refrigerated Display Cases. A repair parts list and wiring diagram are also included in the manual. Read all of these documents carefully before installing or servicing your case.



NOTICE

Read this manual before installing your case. Keep this manual and refer to it before doing any service on the equipment. Failure to do so could result in personal injury or damage to the case.



NOTICE

Installation and service of the electrical components in the case must be performed by a licensed electrician.

The portions of this manual covering components contain technical instructions intended only for persons qualified to perform electrical work.



DANGER

Improper or faulty hookup of electrical components in the case can result in severe injury or death.

All electrical wiring hookups must be done in accordance with all applicable local, regional, or national standards.

SERIAL NUMBER

Record the model and serial numbers of the case for easy reference. Always refer to both model and serial numbers in your correspondence regarding the case.

Case Model _____ Serial Number _____
Condensing Unit Model _____ Serial Number _____

This manual cannot cover every installation, use, or service situation. If you need additional information, call or write us:

WARRANTY/TECHNICAL SERVICE DEPARTMENT
Federal Industries
215 Federal Avenue
Belleville, WI 53508
Toll Free (800) 356-4206 / WI Phone (608) 424-3331

WARNING LABELS & SAFETY INSTRUCTIONS



This is the safety-alert symbol. When you see this symbol on your case or in the manual, be alert to the potential for personal injury or damage to your equipment.

Be sure you understand all safety messages and always follow recommended precautions and safe operating procedures.



NOTICE TO EMPLOYERS

You must make sure that everyone who installs, uses, or services your case is thoroughly familiar with all safety information and procedures.

Important safety information is presented in this section and throughout the manual. The following signal words are used in the warning and safety messages:

DANGER: Severe injury or death will occur if you ignore the message.

WARNING: Severe injury or death can occur if you ignore the message.

CAUTION: Minor injury or damage to your case can occur if you ignore the message.

NOTICE: This is important installation, operation, or service information. If you ignore the message, you may damage your case.

The warning and safety labels shown throughout this manual are placed on your Federal Industries case at the factory. Follow all warning label instructions. If any warning or safety labels become lost or damaged, call our customer service department at 1(800) 356-4206 for replacements.

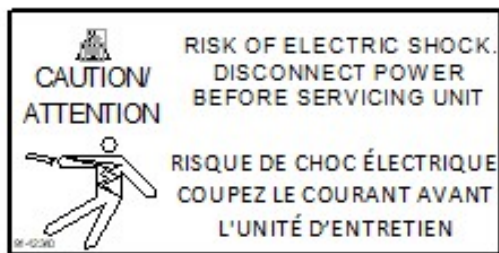

This label is located on the back of the display case.



This label is located below the display pan.

DANGER – Risk of fire or explosion. Flammable refrigerant used. Consult repair manual/owner's guide before attempting to service this product. all safety precautions must be followed

91-2181-4

DANGER — Risque d'incendie ou d'explosion. Fluide frigorigène utilisé. Consulter le guide propriétaire ou le manuel de réparations avant de d'essayer d'installer ou de réparer ce produit. Toutes les précautions de sécurité doivent être suivies.

91-2181-4

This label is located by condensing unit

REFRIGERATION WARNING

INSTALLATION-REPAIR-DECOMMISSIONING

 This is the Danger-Flammable symbol. When you see this symbol on your case or in the manual, be alert to the potential for risk of fire or explosion.

Be sure you understand all the safety messages and always follow recommended precautions and safe operating procedures.

DANGER



Risk of fire or explosion. Flammable refrigerant used. To be repaired only by trained service personnel. Do not puncture refrigerant tubing. Dispose of properly in accordance with federal or local regulations

Consult repair manual/owner's guide before attempting to service this product. All safety precautions must be followed.

Follow handling instructions carefully in compliance with national regulations.

Auxiliary devices which may be ignition sources shall not be installed in the ductwork, other than auxiliary devices listed for use with the specific appliance.

Do not store explosive substances (such as aerosol cans with a flammable propellant) in this case.

Do not use an electrical appliance INSIDE the food storage compartments unless its type is recommended by manufacturer.

Flammable refrigerant type specified on case nameplate is on the serial label.

APPLIES TO R290 REFRIGERANT MODELS ONLY! Contains a charge of R290 refrigerant with a lower flammability limit (LFL) of .038kg/m³. See table for amount of charge.

WARNING

WARNING

- Do not use means to accelerate the defrosting process or to clean, other than those recommended by the manufacturer.
- The appliance shall be stored in a room without continuously operating ignition sources
For example: open flames, an operating gas appliance or an operating electric heater.
- Do not pierce or burn.
- Be aware that refrigerants may not contain an odor.

MISE EN GARDE

- Ne pas utiliser de moyens autres que ceux recommandés par le fabricant pour accélérer le processus de dégivrage ou pour nettoyer l'appareil.
- L'appareil doit être entreposé dans un local ne contenant pas de sources d'inflammation permanentes (flammes nues, appareil à gaz ou dispositif de chauffage électrique en fonctionnement, par exemple).
- Ne pas percer ou brûler.
- Attention, les fluides frigorigènes peuvent ne pas dégager d'odeur.

3. QUALIFICATION: All refrigeration and electrical maintenance, service, and repair must be performed by a Certified Technician that is trained in the required flammable refrigerants safety procedures. Technicians must read the entire section "REFRIGERATION WARNINGS SECTION" of this manual.

Including but not limited to the following:

- a) breaking into the refrigerating circuit.
- b) opening of sealed components.
- c) opening of ventilated enclosures.

4.CHECKS TO AREA: Prior to beginning work on systems containing FLAMMABLE REFRIGERANTS, safety checks are necessary to ensure that the risk of ignition is minimized prior to conducting work on the system.

-Capacitors are discharged: this shall be done in a safe manner to avoid the possibility of sparking.

- No live electrical components and wiring are exposed while charging, recovering or purging the system.

- Continuity of earth bonding.

-Work shall be undertaken under a controlled procedure to minimize the risk of a flammable gas or vapor being present while the work is being performed.

-All maintenance staff and others working in the local area shall be instructed on the nature of the work being carried out. Work in confined spaces shall be avoided.

-The area shall be checked with an appropriate refrigerant detector prior to and during work, to ensure the technician is aware of potentially toxic or flammable atmospheres. Ensure that the leak detection equipment being used is suitable for use with all applicable refrigerants, i.e., non-sparking, adequately sealed, or intrinsically safe.

-If any hot work is to be conducted on the refrigerating equipment or any associated parts, appropriate fire extinguishing equipment shall be available on hand. A dry chemical or CO2 fire extinguisher should be adjacent to the charging area.

-No person carrying out work in relation to a REFRIGERATING SYSTEM which involves exposing any pipe work shall use any sources of ignition in such a manner that it may lead to the risk of fire or explosion. All possible ignition sources, including cigarette smoking, should be kept sufficiently far away from the site of installation, repairing, removing and disposal, during which refrigerant can possibly be released to the surrounding space. Prior to work taking place, the area around the equipment shall be surveyed to make sure that there are no flammable hazards or ignition risks. "No Smoking" signs shall be displayed.

-Ensure that the area is in the open or that it is adequately ventilated before breaking into the system or conducting any hot work. A degree of ventilation shall continue during the period that the work is carried out. The ventilation should safely disperse any released refrigerant and preferably expel it externally into the atmosphere.

-Where electrical components are being changed, they shall be fit for the purpose and to the correct specification so as to minimize the risk of possible ignition due to incorrect parts. At all times, the manufacturer's maintenance and service guidelines shall be followed. If in doubt, consult the manufacturer's technical department for assistance. The following checks shall be applied to installations using flammable refrigerants:

- a) the actual REFRIGERANT CHARGE is in accordance with the room size within which the refrigerant containing parts are installed.
- b) The ventilation machinery and outlets are operating adequately and are not obstructed.
- c) Markings of the equipment continue to be visible and legible. Markings and signs that are illegible shall be corrected.
- d) Refrigerating pipes or components are installed in a position where they are unlikely to be exposed to any substance which may corrode refrigerant containing

-Repair and maintenance to electrical components shall include initial safety checks and component inspection procedures. If a fault exists that could compromise safety, then no electrical supply shall be connected to the circuit until it is satisfactorily dealt with. If the fault cannot be corrected immediately but it is necessary to continue operation, an

An adequate temporary solution should be used. This shall be reported to the owner of the Initial safety checks shall include:

5. REPAIRS TO SEALED COMPONENTS

-During repairs to sealed components, all electrical supplies shall be disconnected from the equipment being worked upon prior to any removal of sealed covers, etc. If it is necessary to have an electrical supply to equipment during servicing, then a permanently operating form of leak detection shall be located at the most critical point to warn of a potentially hazardous situation.

-Particular attention shall be paid to the following to ensure that by working on electrical components, the casing is not altered in such a way that the level of protection is affected. This shall include damage to cables, excessive number of connections, terminals not made to original specification, damage to seals, incorrect fitting of glands, etc. Ensure that the apparatus is mounted securely. Ensure that seals or sealing materials have not degraded to the point that they no longer serve the purpose of preventing the egress of flammable atmospheres. Replacement parts shall be in accordance with the manufacturer's specifications.

-Do not apply any permanent inductive or capacitance loads to the circuit without ensuring that this will not exceed the permissible voltage and current permitted for the equipment in use.

NOTE The use of silicon sealants can inhibit the effectiveness of some types of leak detection equipment. Intrinsically safe components do not have to be isolated prior to working on them.

6. DETECTION OF FLAMMABLE REFRIGERANTS:

Under no circumstances shall potential ignition sources be used in the searching for or detection of refrigerant leaks. A halide torch (or any other detector using a naked flame) shall not be used.

The following leak detection methods are deemed acceptable for all refrigerant systems:

-Electronic leak detectors may be used to detect refrigerant leaks but, in the case of FLAMMABLE REFRIGERANTS, the sensitivity might not be adequate or might need recalibration. (Detection equipment shall be calibrated in a refrigerant-free area.) Ensure that the detector is not a potential source of ignition and is suitable for the refrigerant used. Leak detection equipment shall be set at a percentage of the LFL of the refrigerant and shall be calibrated to the refrigerant employed, and the appropriate percentage of gas (25 % maximum) is confirmed.

-Leak detection fluids are also suitable for use with most refrigerants but the use of detergents containing chlorine shall be avoided as the chlorine can react with the refrigerant and corrode the copper pipework.

NOTE Examples of leak detection fluids are

- bubble method,
- fluorescent method agents.

If a leak is suspected, all naked flames shall be removed/extinguished.

If a leakage of refrigerant is found which requires brazing, all the refrigerants shall be recovered from the system, or isolated (by means of shut off valves) in a part of the system remote from the leak.

7. REMOVAL AND EVACUATION:

When breaking into the refrigerant circuit to make repairs-or for any other purpose-conventional procedures shall be used. However, for flammable refrigerants it is important that the best practice be followed, since flammability is a consideration. The following procedure shall be adhered to:

- a. Safely remove refrigerant following local and national regulations.
- b. Purge the circuit with inert gas.
- c. Evacuate (optional for A2L).
- d. Purge with inert gas (optional for A2L).
- e. Open the circuit by cutting or brazing.

The refrigerant change shall be recovered into the correct recovery cylinders if venting is not allowed by local and national codes. For appliances containing flammable refrigerants, the system shall be purged with oxygen-free nitrogen to render the appliance safe for flammable refrigerants. This process might need to be repeated several times. Compressed air or oxygen shall not be used for purging refrigerant systems. For appliances containing flammable refrigerants, refrigerant purging shall be achieved by breaking the vacuum in the system with oxygen-free nitrogen and continuing to fill until the working pressure is achieved, then venting to atmosphere, and finally pulling down to a vacuum (optional for A2L). This process shall be repeated until no refrigerant is within the system (optional for A2L). When the final oxygen-free nitrogen change is used, the system shall be vented down to atmospheric pressure to enable work to take place. Ensure that the outlet for the vacuum pump is not close to any potential ignition sources and that ventilation is available.

8. CHARGING PROCEDURES:

In addition to conventional charging procedures, the following requirements shall be followed.

- a. Ensure that contamination of different refrigerants does not occur when using charging equipment. Hoses or lines shall be as short as possible to minimize the amount of refrigerant contained in them.
- b. Cylinders should be kept in an appropriate position according to the instructions.
- c. Ensure that the REFRIGERATING SYSTEM is earthed prior to charging the system with refrigerant.
- d. Label the system when charging is complete (if not already).
- e. Extreme care shall be taken not to overfill the REFRIGERATING SYSTEM.

9. DECOMMISSIONING:

Before carrying out this procedure, it is essential that the technician is completely familiar with the equipment and all its details. It is recommended good practice that all refrigerants are recovered safely. Prior to the task being carried out, an oil and refrigerant sample shall be taken in case analysis is required prior to re-use of recovered refrigerant. It is essential that electrical power is available before the task commences.

- a. Become familiar with the equipment and its operation.
- b. Isolate the system electrically.
- c. Before attempting the procedure, ensure that:
 - i. Mechanical handling equipment is available, if required, for handling refrigerant cylinders.
 - ii. All personal protective equipment is available and is being used correctly.
 - iii. The recovery process is supervised at all times by a competent person.
 - iv. Recovery equipment and cylinders conform to the appropriate standards.
- d. Pump down the refrigerant system, if possible.
- e. If a vacuum is not possible, make a manifold so that refrigerant can be removed from various parts of the system.
- f. Make sure that the cylinder is situated on the scales before recovery takes place.
- g. Start the recovery machine and operate in accordance with instructions.
- h. Do not overfill cylinders (no more than 80% volume liquid charge).
- i. Do not exceed the maximum working pressure of the cylinder, even temporarily.

10. LABELING:

Equipment shall be labeled stating that it has been de-commissioned and emptied of refrigerant. The label shall be dated and signed. For appliances containing flammable refrigerants, ensure that there are labels on the equipment stating the equipment contains flammable refrigerant.

11. RECOVERY:

When removing the refrigerant from a system, either for servicing or decommissioning, it is recommended good practice that all refrigerants are removed safely.

When transferring refrigerant into cylinders, ensure that only appropriate refrigerant recovery cylinders are employed. Ensure that the correct number of cylinders for holding the total system charge is available. All cylinders to be used are designated for the recovered refrigerant and labeled for that refrigerant (i.e., special cylinders for the recovery of refrigerant). Cylinders shall be complete with pressure-relief valve and associated shut-off valve in good working order. Empty recovery cylinders are evacuated and, if possible, cooled before recovery occurs.

The recovery equipment shall be in good working order with a set of instructions concerning the equipment that is at hand and shall be suitable for the recovery of all appropriate refrigerants including, when applicable, FLAMMABLE REFRIGERANTS. In addition, a set of calibrated weighing scales shall be available and in good working order. Hoses shall be complete with leak-free disconnect coupling and in good condition. Before using the recovery machine, check that it is in satisfactory working order, has been properly maintained and that any associated electrical components are sealed to prevent ignition in the event of refrigerant release. Consult manufacturer if in doubt.

The recovered refrigerant shall be returned to the refrigerant supplier in the correct recovery cylinder, and the relevant waste transfer note arranged. Do not mix refrigerants in recovery units and especially not in cylinders. If compressors or compressor oils are to be removed, ensure that they have been evacuated to an acceptable level to make certain that FLAMMABLE REFRIGERANT does not remain within the lubricant. The evacuation process shall be carried out prior to returning the compressor to the suppliers. Only electric heating to the compressor body shall be employed to accelerate this process. When oil is drained from a system, it shall be carried out safely.

PRE-INSTALLATION PROCEDURES

Inspection for Shipping Damage

You are responsible for filing all freight claims with the delivery truck line. Inspect all cartons and crates for damage as soon as they arrive. If damage is noted to shipping crates, cartons, or if a shortage is found, note this on the bill of lading (all copies) prior to signing.

If damage is discovered when the case is uncrated, immediately call the delivery truck line and follow up the call with a written report indicating concealed damage to your shipment. Ask for an immediate inspection of your concealed damage item. Crating material must be retained to show the inspector from the truck line.

INSTALLATION INSTRUCTIONS

IMPORTANT: Read this Section of this manual located on page 6.

“REFRIGERATION WARNING &INSTALLATION-REPAIR-DECOMMISSIONING”

All refrigeration and electrical work must be performed by certified technicians.

The installation of the appliance and the refrigerant must only be performed by Federals approved Service or suitably qualified person.

Appliance to be installed in accordance with safety standards ANSI/ASHREA 15.

The appliance shall not be installed in public corridors or lobbies.

This case is designed for a class 2 environment.

<u>Test room climate class</u>	<u>Dry bulb temperature [°F]</u>	<u>Relative Humidity [%]</u>	<u>Dew point [°F]</u>	<u>Water vapour mass in dry air [lbm water/lbm air]</u>	<u>Required Test Lab Temperature [°F]</u>
2.0	71.6	65	59.36	0.0108	89.6

NSF TYPE 1 Temperature cannot exceed 75 deg F and 55% humidity.

LOCATING THE DISPLAY CASE

The case should be located where it is not subjected to the direct rays of the sun, heating ducts, grills, radiator, or ceiling fans, nor should it be located near open doors or main door entrances. Also, avoid locations where there are excessive air movement or air disturbances.

The condenser air inlet is located at the rear of the case. Do not block this inlet and do not locate the air inlet near a source of heat.

REMOVING CASE FROM SHIPPING SKID



CAUTION: Do not push against the top glass, front glass, end glass, doors or door frames when removing the case from the skid or moving the case. Case damage or glass breakage could result.

1. Remove crate top and sides and note missing or damaged items as explained in the pre-installation procedures outlined above.
2. Move the case as near as possible to the final location and before removing it from the shipping skid.
3. If your case is supplied with plastic end panels, remove them by lifting them in an upward direction. Set these end panels aside to be reinstalled after case is placed in proper position.
4. Remove the (4) brackets that secure the case to the shipping skid.
5. Use the lifting handles located in each end of the case and lift case off of skid and into required position.
6. Level and square the case as needed by adjusting the leg leveler in each corner of base. (Use the wrench provided.) (The case must be level for proper drainage of defrost condensate to the condensate evaporator and allow for proper alignment of front glass.) The 50", 59", & 77" cases also have a set of leg levelers in the center. These must be adjusted until the bottom of the base is flat. Failure to adjust center leg could cause rear sliding doors to fall out of track.
7. The leveled case must be sealed to the floor using a NSF Listed Sealant.
8. If plastic end panels are required reinstall them on to case. Hook the key slot located on the inside of the end panel down over screws located on each end of case.

GRILL REMOVAL (REFRIGERATED UNITS)



DANGER: Electric shock hazard. Do not operate unit with panels removed.

There is a removable slotted panel at the rear of the case. The panel allows access to the condensing unit, the light ballast/ LED power supply, the condensate pan, and the field wiring connection box. Remove this panel to make field wiring connections. See electrical information and grounding section of this manual before wiring case.

Note: If electrical connection has been performed, disconnect power to case before removing grill panel.

1. Remove the rear grill panel screws from top of rear grill.
2. Tilt the top of rear grill panel outward as shown in illustration on the right.

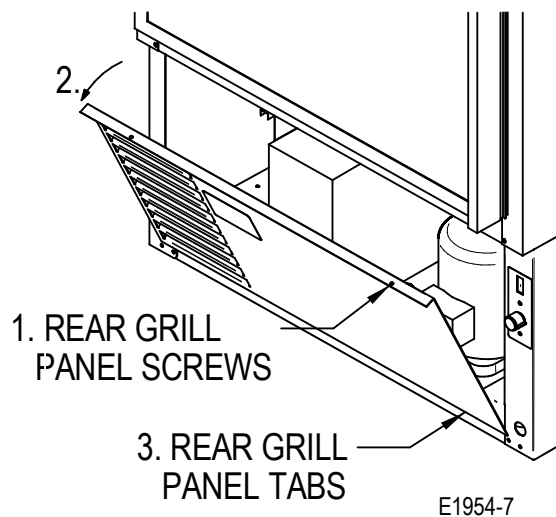

3. Pull rear grill panel tabs up and out of slots in base of case.

CONDENSATE EVAPORATOR (REFRIGERATED UNITS)

This case is furnished with a hot gas condensate evaporator. Plumbing connections are not required.

The condensate evaporator is located under the condensing unit in the machine compartment and is accessible from the rear of the case. After removal of rear grill panel, make sure that the drain line has not been dislodged during shipment and that the drain trap is attached to the bottom of the evaporator tub and the hose is attached the water reservoir of the condensate evaporator pan.

CLEANING

For initial setup, clean the case as outlined in the weekly cleaning section of this manual.

TRIM KITS INSTALLATION

Follow the “Case Installation” procedures in this manual for each display case that is going to be adjoined in a line up. Additional cases must be placed directly next to the adjoining end of the first case. Push cases together as close as possible keeping the front of the cases in alignment. Once adjoining case is in proper position complete all of the procedures outlined in the “Case Installation” section in this manual before installing the trim kit as outlined below.

Note: The Laminated plastic end panels and end panel screws are not used on the adjoining ends of the cases that are to be butted together.

EXTERIOR TRIM

1. Remove the (3) 8-32 screws located on rear corner of each case and set aside (If preinstalled). These screws will be used to attach rear exterior trim strip to case. Note: For units with rear packing shelf. These screws hold the package shelf standard to the case. The packing shelf and packing shelf standard must be temporarily removed for installation of rear exterior trim.

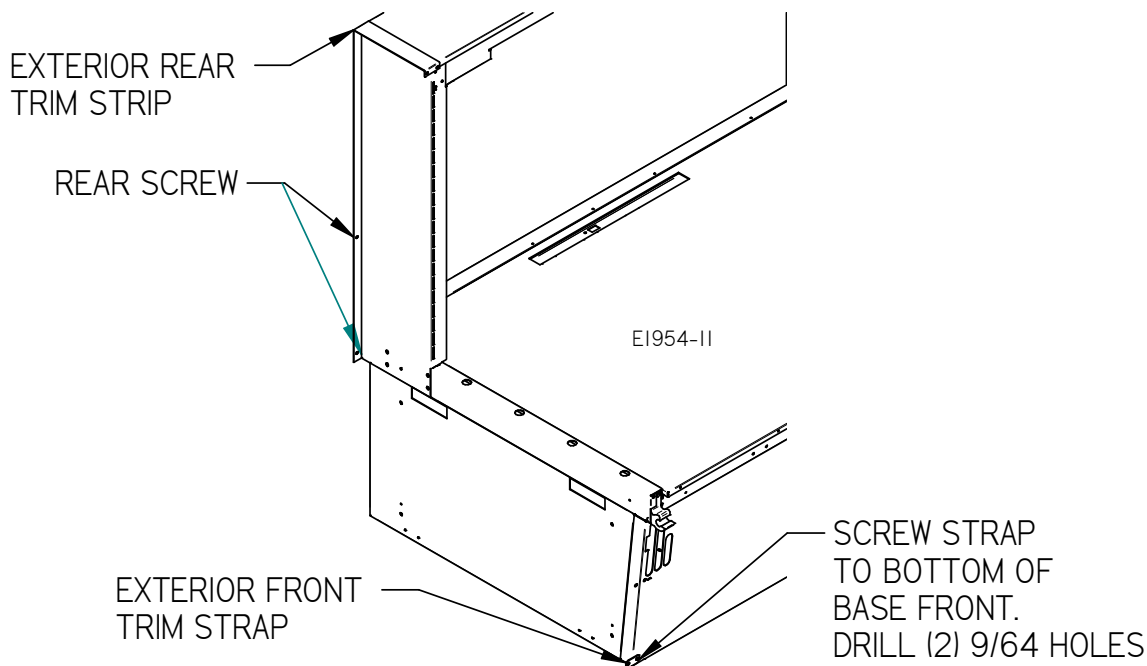

2. Remove the adhesive liner from the inside of the rear exterior trim strip and firmly place it over the top and down the back of case. Be sure to center rear exterior trim strip over seam between cases and to align slots with holes in case rear (If holes are provided)
3. Fasten rear exterior trim strip to each case with the (3) 8-32 screws previously removed. If no holes are provided to fasten trim strip, use the (3) #8 self-drilling screws provided. Note: For units with rear packing shelf, reattach rear packing shelf standard over the top of rear exterior trim strip using the existing holes in case. Place packing shelf back on to case in desired standard slot.
4. Use a NSF approved silicone to seal the rear exterior trim strip along the top surface of case.
5. Fasten front exterior trim strap to each case with the (2) 8-32 screws. Drill (2) 9/64 holes in the lower portion of the base front to attach strap. Note: For units with front package shelf, reattach front package shelf over the top of front exterior trim strap case with the (2) 8-32 screws previously removed.

INTERIOR TRIM

The interior trim kit is used when adjoining cases have one glass panel or no glass panel between them.

1. On units with sliding rear doors, remove both rear doors from the track by lifting doors upward until the bottom edge of door clears the lower track. Swing the bottom of door outward and down out of top track.

On units with rear swing doors completely open doors to allow access to the interior of case.

2. **Cases with no glass panels:** Remove the adhesive liner from the inside of the interior trim strip and firmly place it over the center gap between the case interiors.

Cases with one glass panel: The interior glass trim is placed in the adjoining case that does not have an end glass panel. Remove the adhesive liner from the inside of the interior trim strip and firmly place it against the glass trim of adjoining case with the end glass panel.

Fasten interior glass trim with the stainless-steel self-drilling screws supplied with interior trim kit

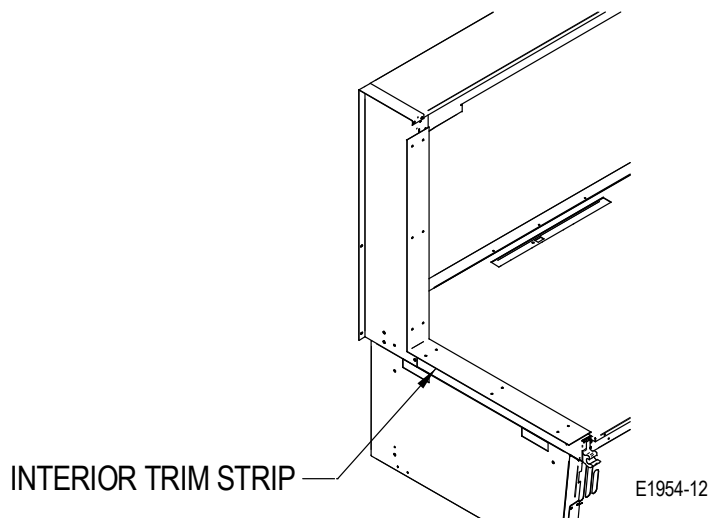

REFRIGERATION INSTALLATION (REFRIGERATED UNITS)

SELF-CONTAINED MODELS

The self-contained models are shipped from the factory with a completely operational refrigeration system and require no modifications or adjustments upon installation.

REMOTE MODELS

The remote models are shipped from the factory with the evaporator coil, expansion valve, refrigerant solenoid valve and thermostat. The thermostat senses interior case temperatures and opens and closes the refrigerant solenoid valve as needed to maintain proper case temperatures. The condensing unit is optionally supplied from the factory for remote location installation.

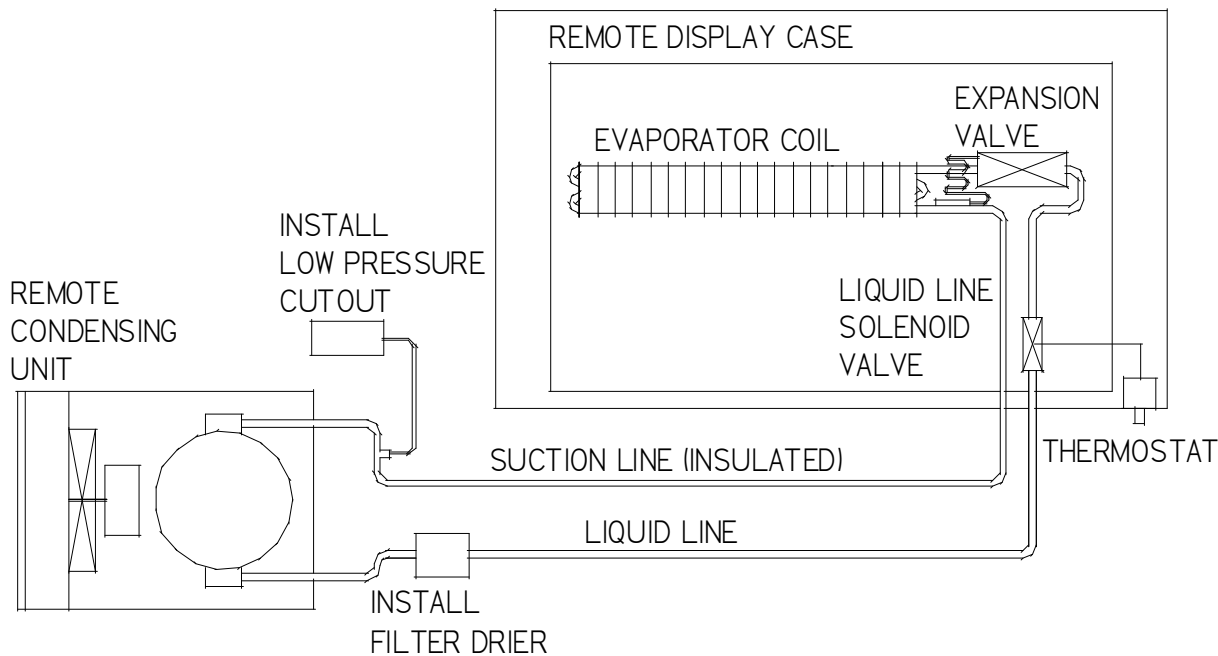

1. Mount condensing unit indoors as close to the remote display case as practical. The refrigeration line should be as short as possible.
2. All refrigeration and/or electrical materials between the condensing unit and display case are to be supplied by the installation contractor.
3. Route properly sized and designed refrigeration lines from the condensing unit to the cabinet. Horizontal suction lines should be pitched downward towards the condensing unit at least $\frac{1}{2}$ " per 10' run to aid the oil drainage. A "P" trap must be installed in the suction line at the foot of every riser to insure oil return. Dry nitrogen should be used to flow through tubing while brazing refrigeration lines.
3. Suction line must be insulated the entire length with Armaflex (or equivalent). Do not run the liquid line inside insulation with suction line.
4. Leak check condensing unit, cabinet, and all connecting tubing. Cabinet and condensing unit tubing should be checked to insure no leaks occurred during shipping or from rough handling. Make certain all refrigeration valves are opened and evacuate system to 500 microns. Charge the system with refrigerant type specified on the data plates.

ELECTRICAL INFORMATION & GROUNDING

This Case Must Be Grounded



DANGER: Improper or faulty hookup of electrical components in the display case can result in severe injury or death.

ELECTRICAL DATA

		PERMANENT CONNECT 2-WIRE PLUS GROUND 120V / 60H / 1PH			PERMANENT CONNECT 2-WIRE PLUS GROUND 120V / 60H / 1PH	
REFRIGERATION & ELECTRICAL DATA		AMPS	MAX FUSE SIZE	OPTIONAL NEMA CORD & PLUG	AMPS	MAX FUSE SIZE
NON REFRIGERATED						
CGD3642	SGD3642	1.5	15	NEMA 5-15P		
CGD3648	SGD3648	1.5	15	NEMA 5-15P		
CGD5042	SGD5042	1.5	15	NEMA 5-15P		
CGD5048	SGD5048	1.5	15	NEMA 5-15P		
CGD5942	SGD5942	1.5	15	NEMA 5-15P		
CGD5948	SGD5948	1.5	15	NEMA 5-15P		
CGD7742	SGD7742	1.5	15	NEMA 5-15P		
CGD7748	SGD7748	1.5	15	NEMA 5-15P		
REFRIGERATED SELF CONTAINED R290					REMOTE REFRIGERATION	
CGR3642	SGR3642	12	15	NEMA 5-15P	3	15
CGR3648	SGR3648	12	15	NEMA 5-15P	3	15
CGR5042	SGR5042	12	15	NEMA 5-15P	3	15
CGR5048	SGR5048	12	15	NEMA 5-15P	3	15
CGR5942	SGR5942	12	15	NEMA 5-15P	4	15
CGR5948	SGR5948	12	15	NEMA 5-15P	4	15
CGR7742	SGR7742	16	20	NEMA 5-20P	5	15
CGR7748	SGR7748	16	20	NEMA 5-20P	5	15
CGR5042DZ	SGR5042DZ	12	15	NEMA 5-15P	3	15
CGR5048DZ	SGR5048DZ	12	15	NEMA 5-15P	3	15
CGR5942DZ	SGR5942DZ	12	15	NEMA 5-15P	3	15
CGR5948DZ	SGR5948DZ	12	15	NEMA 5-15P	3	15
CGR7742DZ	SGR7742DZ	12	15	NEMA 5-15P	3	15
CGR7748DZ	SGR7748DZ	12	15	NEMA 5-15P	3	15
CGR3642CD	SGR3642CD	12	15	NEMA 5-15P	3	15
CGR3648CD	SGR3648CD	12	15	NEMA 5-15P	3	15
CGR5042CD	SGR5042CD	12	15	NEMA 5-15P	3	15
CGR5048CD	SGR5048CD	12	15	NEMA 5-15P	3	15
CGR5942CD	SGR5942CD	12	15	NEMA 5-15P	4	15
CGR5948CD	SGR5948CD	12	15	NEMA 5-15P	4	15
CGR7742CD	SGR7742CD	16	20	NEMA 5-20P	5	15
CGR7748CD	SGR7748CD	16	20	NEMA 5-20P	5	15

Refer to the data plate attached to rear of the case for maximum fuse size and minimum circuit amp

CORD CONNECTED

All standard models are supplied with a power cord that is properly sized to the amperage requirements of the case. See the electrical data plate located on the rear left interior ceiling of the case for the proper circuit size for each case.

The cord is factory installed protruding from the bottom rear corner of the case.

A separate circuit for each display case is required to prevent other appliances on the same circuit from overloading the circuit and causing malfunction.

Only a licensed electrician must perform all case electrical connections.

All electrical wiring hookups must be done in accordance with all applicable local, regional, or national electrical standards.

A separate circuit for each display case is recommended to prevent other appliances on the same circuit from overloading the circuit and causing malfunction.

The electrical service must be grounded upon installation.

This unit is designed for permanent connection to a power source. See the electrical data plate located at the rear of the case for proper circuit size and wire ampacity.

The electrical connection box is accessible from the rear of the case. Remove rear grill on refrigerated models. (See "Grill Removal" in the installation section of this manual.) See Diagram below for location of the field wiring connection box.

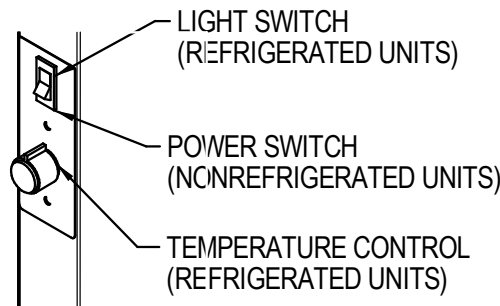
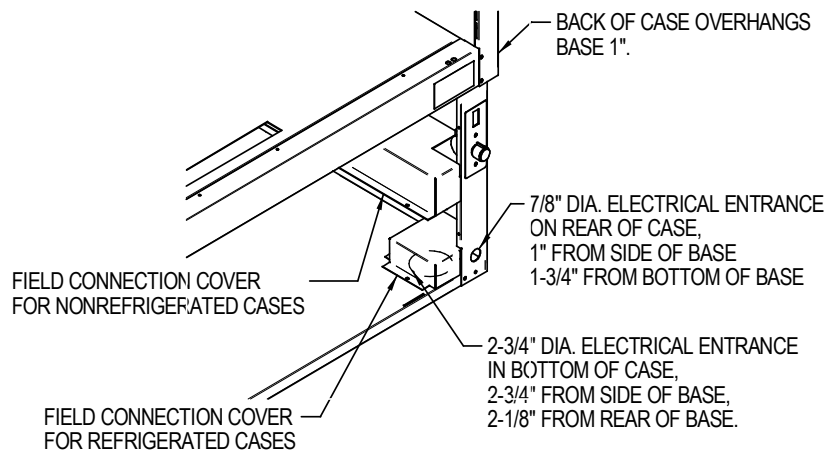

E1954-8

OPERATING INSTRUCTIONS

CONTROLS (REFRIGERATED UNITS)

Light Switch

This switch controls the power to the lighting circuit. The switch rocker is red in the “on” position, black in the “off” position.

Temperature Control

This controls the refrigerated side by cycling the compressor/condensing unit. It has an “off” position and the coldest setting when the knob is set all the way in the clockwise position. Set this control at the lowest setting possible, while maintaining desired case temperature.

CONTROLS (NON-REFRIGERATED UNITS)

Power Switch

This switch controls the power to the lighting circuit and to the optional interior fan if supplied. The switch rocker is red in the “on” position and black in the “off” position.

SHELVES

Each display is furnished with shelves that are adjustable up and down and can be tilted in three angular positions. See “Shelving Installation & Removal” section of this manual for proper installation, adjustment and removal of shelving.

REAR PACKAGE SHELF (standard on Deli, optional on all other models)

The rear package shelf is removable and adjustable up and down. It can be removed or adjusted by lifting rear package shelf up and out until the bracket is disengaged from shelf standard. It can then be moved to desired height location and reattached.

SLIDING REAR DOORS

The doors can be easily removed by lifting doors upward until the bottom edge of door clears the lower track. Swing the bottom of door outward and down out of top track.

Clean the door track frequently for easy door operation. A Very light film of lubricant, such as PAM, will help the doors slide easily.

SWING REAR DOORS

Rear swing door on 31” wide dry cases only.

The Swing doors are not easily removable for cleaning and require no lubrication.

PLACING PRODUCT INTO CASE

After completing shelving installation as outlined in “Shelving Installation and Removal” section of this manual you may begin placing product into the display case.

- Do not exceed 150 pounds of weight per shelf. Heavy product should be distributed evenly across the entire shelving area.
- Determine desired shelving location and angle before placing product in case. Product must be removed to readjust shelf location and angle.

(Refrigerated Models)

- Do not overhang the front of wire shelves with product. Product may overhang rear of shelf but allow a minimum of 1-1/2” between product and rear door. Improper clearance in front and rear of the shelf will block the refrigerated airflow and could cause product loss.

-Do not block the slots along the front or rear of the case display pan. Covering these slots will block the refrigerated airflow and could cause product loss.

-The display pan is removable for cleaning and can become dislodged in shipment. To ensure proper airflow and performance of the case, make sure that the display pan is pushed completely down into evaporation tub. Check that the pan is installed properly before placing product the display pans.

-Allow refrigerated models to run for at least two hours before placing pre-chilled product into unit. Turn temperature control to the lowest possible position that maintains the required interior cabinet temperature.

-CASE SHOULD BE STOCKED WITH PRE-CHILLED PRODUCT ONLY.

ATTENTION:

- Federal refrigerated display cases are designed to operate in a maximum environment of 75 DEG. F and 55% relative humidity. Exceeding these limits could cause poor case performance and sweating of glass panels.

SHELVING INSTALLATION & REMOVAL

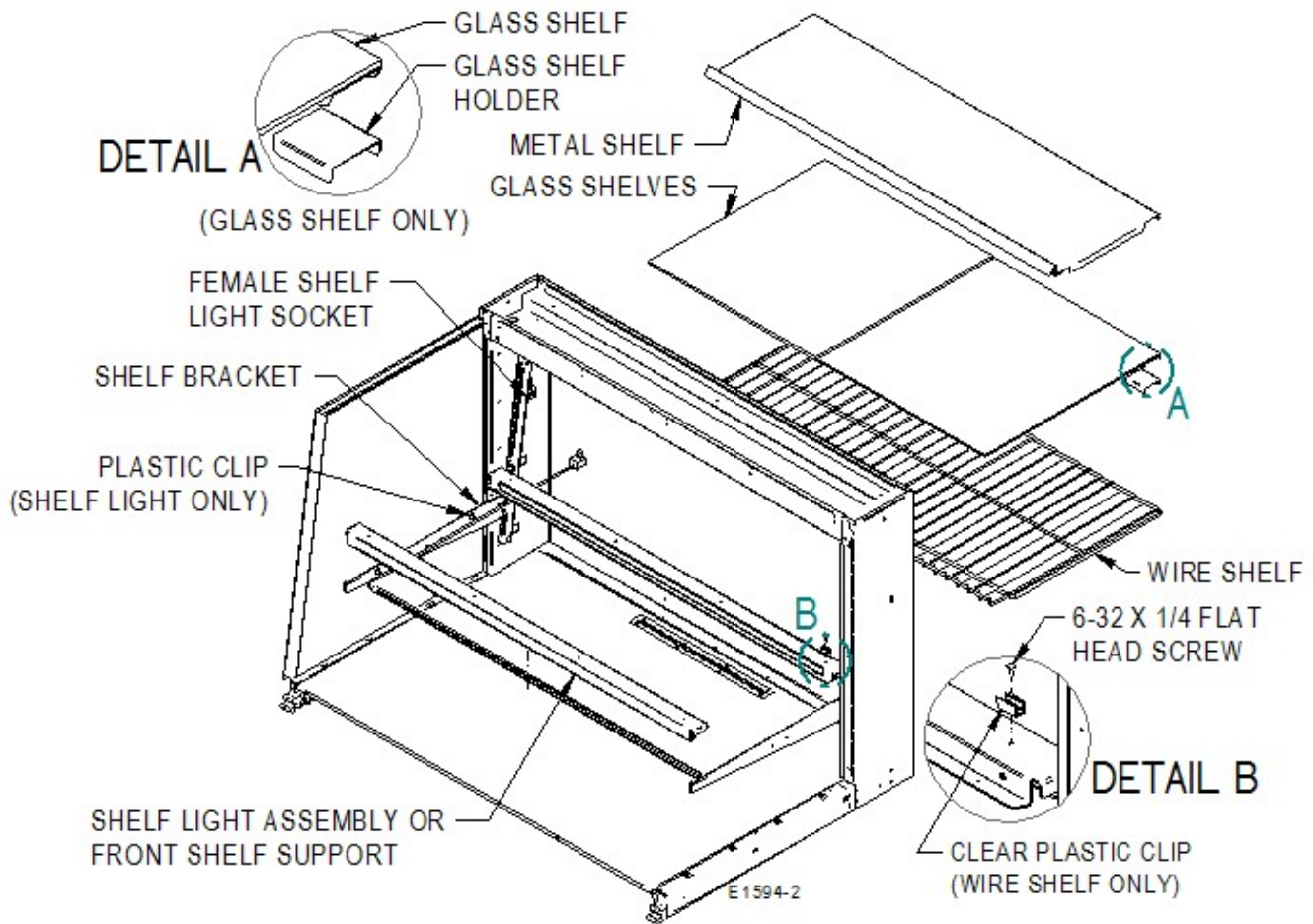

1. Turn the light switch to the off position. On units with sliding rear doors, remove both rear doors from the track by lifting doors upward until the bottom edge of door clears the lower track. Swing the bottom of door outward and down out of top track. On units with rear swing doors completely open doors to allow access to the interior of case.
2. Insert a shelf bracket in the desired shelf standard slot on one side of the case. Follow the instructions in the illustration below. Place an additional shelf bracket in the same shelf standard slot on the opposite end of case. Repeat for additional shelf tiers. For first time installation, it may be necessary to attach the clear plastic clips to only the shelf brackets located on the side of the shelf light cord. NOTE: Do not allow shelf bracket to hit side glass

INSTALLATION

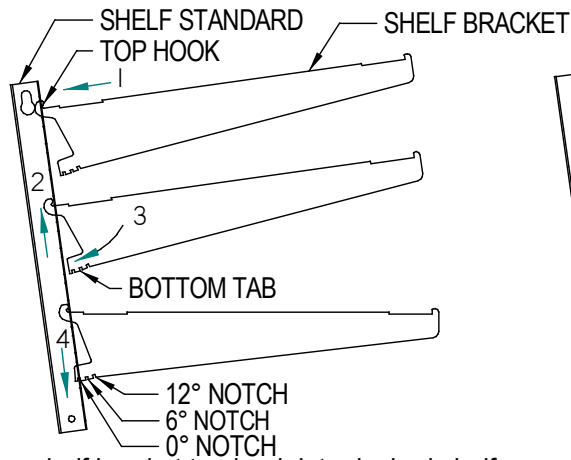

REMOVAL

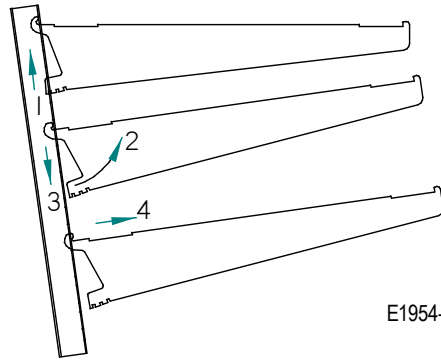

E1954-3

- A.. Place shelf bracket top hook into desired shelf standard slot.
 - B. Lift shelf bracket top hook to allow shelf bracket bottom tab to clear shelf standard slot.
 - C. Swing shelf bracket bottom tab into shelf standard slot.
 - D. Place the desired shelf bracket notch of 0, 6, or 12 degrees onto bottom of shelf standard slot.
- A. Lift shelf bracket up to allow shelf bracket notch to clear the bottom of shelf standard slot.
 - B. Swing shelf bracket bottom tab out of shelf standard slot.
 - C. Drop shelf bracket down to allow shelf bracket top hook to clear top of shelf standard slot.
 - D. remove shelf bracket top from shelf standard slot.

3. Hang one end of shelf light assembly on the front notch of a shelf bracket with light facing rear of case and then the other end of shelf light housing on the notch of the shelf bracket on the opposite end. Repeat for each additional shelf tiers. NOTE: On models without shelf lights, use a shelf support instead of a shelf light assembly.
4. Push shelf light cords into plastic clip located on inside of shelf brackets.
5. Remove the cap from the appropriate female light sockets. If the socket is not being used for a shelf light, the cap must be plugged into socket for the entire light system to operate. NOTE: Grip each side of cap firmly and wiggle and pull cap straight out of socket. Do not roll cap during removal.
6. Plug in each shelf light by aligning the male pins on the appropriate shelf light cord plugs with the female light sockets and push together. NOTE: Do not roll plug during insertion.
7. Hang one end of the shelf support on to the rear notch of one shelf bracket and then on the rear notch of the shelf bracket on the opposite side. Repeat for additional shelf tiers.
8. Place supplied shelving onto shelf supports as outlined in the appropriate "Shelf Installation" section of this manual.
9. On units with sliding rear doors, re-install both rear doors by lifting the top of door into top track and swinging bottom of door onto bottom track. Install door labeled "inner door" first on inner track and door labeled "outer door" second on outer track.

SHELVES AND SHELF LIGHT QUANTITY

It is not required that all shelves and shelf lights supplied with each case are used. The quantity of shelves and shelf lights can be tailored to your specific needs. If the supplied quantity of shelves and shelf lights are not required, cap unused female socket located in interior of the case mullion with caps supplied. Failure to do so will prevent the entire lighting system from operating.

SHELF INSTALLATION

WIRE SHELVES

1. For first time installation, it may be necessary to attach the clear plastic clips to each end of the rear shelf supports. Use the 6-32 x ¼ flat head screws supplied with unit to attach clear plastic clips to the 1/8 hole on each side of shelf support. This step may have already been performed at the factory for you. Repeat for each rear shelf support tier. (See illustration E1594-2 Detail C)
2. With rear sliding doors removed or rear swing door open, place the front of wire shelf onto front shelf light. (On front shelf support for models without shelf lights)
3. Snap the rear of the shelf into the clear plastic clips on rear shelf support.
4. Repeat 2 & 3 for each tier.

NOTE: Units with 73" long rear shelf supports uses (2) wire shelves per tier. All other units use (1) wire shelf per tier.

GLASS SHELVES

1. For the first time installation attach (2) glass shelf holders to each glass shelf. Remove the backing from tape located on flat side of glass shelf holder. Position the glass shelf holders in the (2) far corners of glass. (See illustration E1594-2 Detail A.) Repeat for each glass shelf. This step may have already been performed at the factory for you

NOTE: Clean area of glass where glass shelf holder is to be located with rubbing alcohol and let air dry before installing shelf glass holder.

2. With rear sliding doors removed or rear swing doors open, place front of glass shelf onto front shelf light. (On front shelf support for models without shelf lights.)
3. Let the rear of the glass shelf onto the rear shelf support so that the glass shelf holder straddles the rear shelf support. If clear plastic clips were factory-installed on top of rear shelf support, remove and discard clear plastic clips.
4. Repeat steps 2 & 3 for each tier.

NOTE: Units with 46" or longer rear shelf supports use (2) glass shelves per tier. All other units use (1) glass shelf per tier.

METAL SHELVES

1. With rear sliding door removed, or rear swing door open, place front of metal shelf on to front shelf light. (On front shelf support on models without shelf lights.)
2. Set the rear of the metal shelf on to the rear shelf support so that the notch at each end of metal shelf straddles the rear shelf support. If clear plastic clips were factory-installed on top of rear shelf support, remove and discard clear plastic clips.
3. Repeat steps 2 & 3 for each tier if supplied with more than (1) tier of shelving.

MAINTENANCE

LED SHELF LIGHT REPLACEMENT

1. On units with sliding rear doors, remove both rear doors from track by lifting doors upward until the bottom edge of door clears the lower track. Swing the bottom of door outward and down out of top track. On units with rear swing doors completely open doors to allow access to interior of case.
2. Remove shelving from unit through rear door opening.
3. Unplug appropriate light housing cord from socket and remove shelf light assembly from unit through rear door opening.
4. Unplug the shelf light cord from the LED light. Starting at the end opposite the light cord, insert a putty knife or flat bladed screw driver between the shelf support and the LED light. This needs to be done to detach the double-sided tape that holds the LED light to the front shelf support.
5. Remove all double-sided tape residue from shelf support. Clean the backside of the new LED light and the mounting surface on the shelf support with isopropyl alcohol and allow to dry, before applying new double side tape to the back of the LED light. The LED light will be positioned between the two .094" holes on the shelf support, with each end of the light on the edge of the hole leaving both holes completely visible.

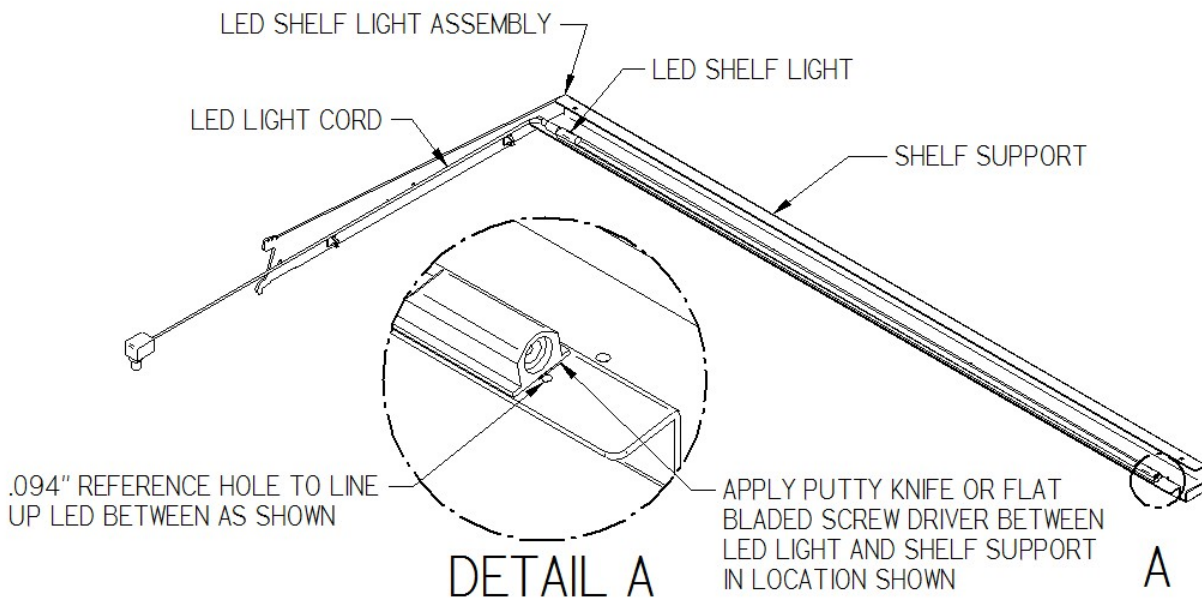

LED TOP LIGHT REPLACEMENT

1. On units with sliding rear doors, remove both rear doors from track by lifting doors upward until the bottom edge of door clears the lower track. Swing the bottom of door outward and down out of top track. On units with rear swing doors completely open doors to allow access to interior of case.
2. Remove all shelves, shelf supports and Shelf light assemblies from unit through rear door opening. (See “Shelving Installation and Removal” section of this manual for instruction if needed)
3. Unplug top light cord from top light.
4. To remove the LED light from the light clips that are mounted to the bottom of the top glass support, push the light in line with the mounting surface on the light clip then rotate the LED towards the front of the case.
5. Reinstall new LED in the same manner as described in the LED Removal Procedure. Be sure that LED is secure in light clips. **Note: Be sure to use a direct equivalent to the original LED.** Plug the top light cord into the new LED top light.

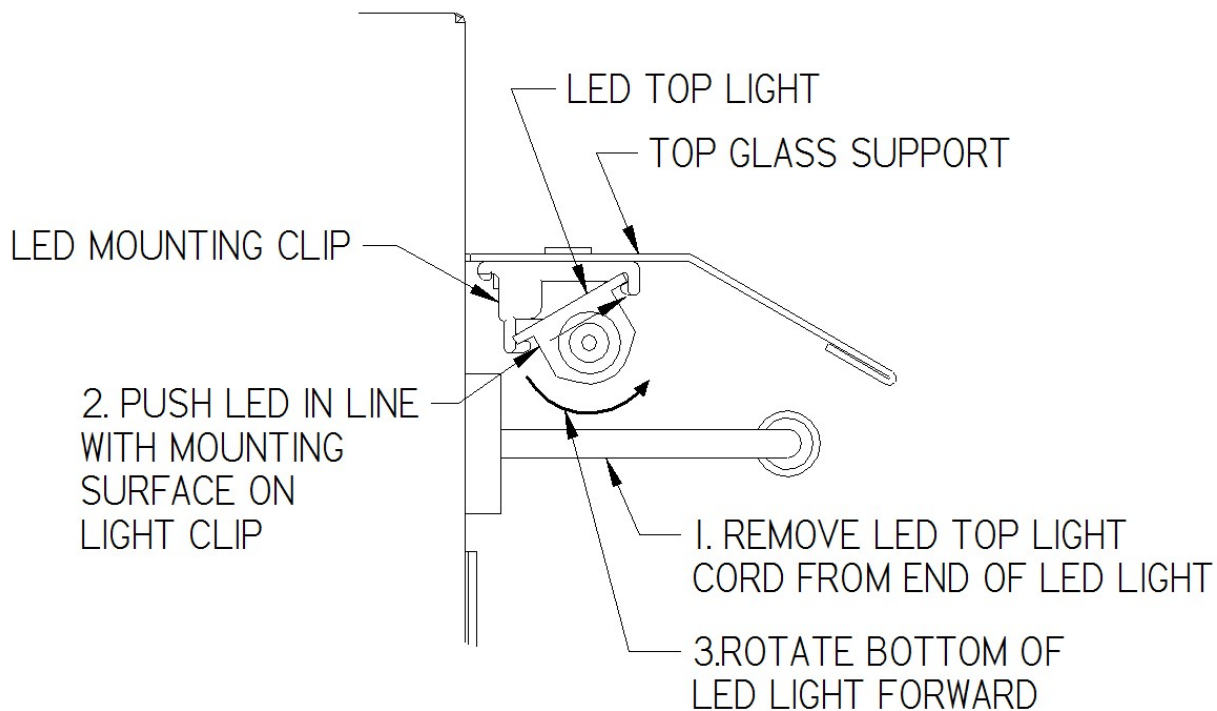

PERIODIC MAINTENANCE

CLEANING CONDENSER COIL FILTER (SELF CONTAINED REFRIGERATED UNITS ONLY)

This refrigerated case is equipped with a reusable condenser coil filter, which filters large dust particles from the air before air enters the condenser coil fins. It is very important that this filter be cleaned on a monthly basis to ensure proper refrigeration performance and to prevent compressor failure.

For 36", 50", 59" & 77" long units with filter access cover:

1. Lift filter access cover latch so the latch stays in a horizontal position.
2. Tilt filter access cover outward and pull filter access cover tab out of notch in rear grill panel.
3. Slide filter out toward rear of case using the filter pull strap on filter.
4. Wash the filter using warm soapy water, rinse, and let dry.
5. Apply a generous coat of filter coat adhesive to both sides of filter.
(Filter coat adhesive is available through any restaurant supply distributor.)

NOTE: Failure to coat filter with a fresh coat of filter adhesive after cleaning will prevent filter from working properly. Failure to do so will allow the condenser coil to plug, which will affect refrigeration performance and could cause compressor failure.

6. Reinstall filter (filter pull-tab facing outward) and filter access cover in reverse order.

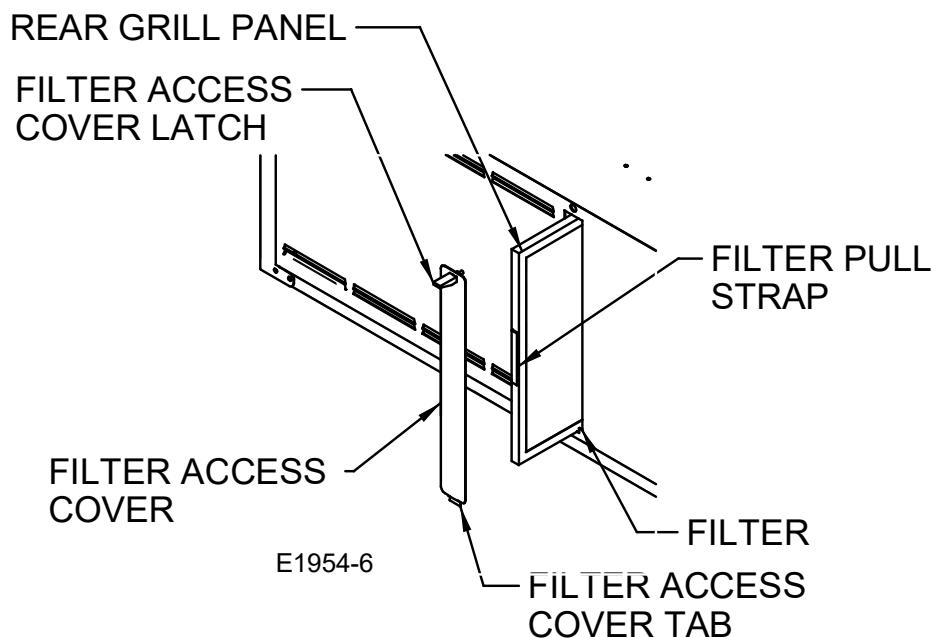

CLEANING CONDENSER COIL (ALL SELF CONTAINED REFRIGERATED CASES)

Even though your refrigerated display case is provided with a reusable condenser air filter, the condenser coil must be checked and cleaned at least every 6 months or as necessary.

1. Disconnect power to the unit.
2. Remove rear grill as described in the installation instruction section of this manual.
3. Slide filter out toward rear of case using the filter pull strap on filter.
4. Wash filter as described in cleaning condenser coil filter in this section of this manual.
5. Vacuum the front surface of the condenser coil.
6. Reinstall filter (filter pull-tab facing outward) and rear grill in the reverse order.

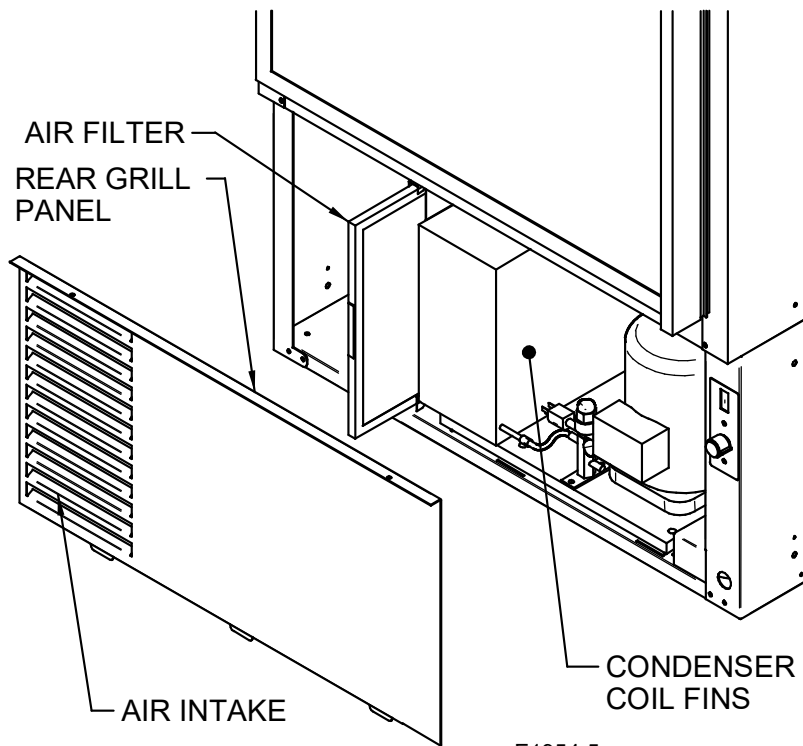

CLEANING INSTRUCTIONS

DAILY CLEANING

The case should be cleaned thoroughly, as described in the weekly cleaning section, before it is used for the first time.



NOTICE: Avoid splashing or soaking any electrical components with water to prevent electrical damage to the case.



NOTICE: Shut off lights and power switches and remove all the products from case. Allow sufficient time for the unit to reach room temperature before proceeding with cleaning.



NOTICE: Remove all products from case before proceeding with cleaning procedure.

Note: For major spills or foreign material buildup use complete weekly cleaning instructions.

1. Clean all foreign materials from the door opening.
2. Wipe the complete interior of case using a damp cloth.
3. Tilt the front glass forward as described in the illustrations below. This will allow easier access to clean interior front and side glass. The glass can then be cleaned with common window cleaners.

NOTE: On models that the front glass does not tilt out, the inside of glass must be cleaned through the rear door access.

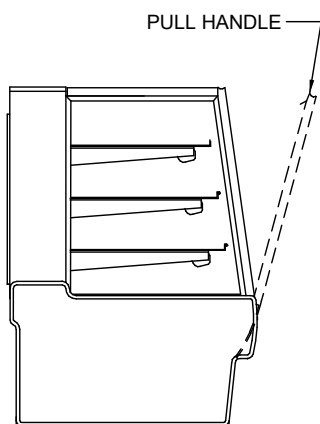

OPEN FRONT GLASS:

1. Stand in front of unit and grab the pull handle with finger tips. It may be necessary to push on front glass from inside of case.
2. Pull front glass outward until the glass rests on front glass stops.

CLOSE FRONT GLASS:

1. Stand in front of unit and push on front of front glass with both hands.
2. Firmly push front glass towards rear of unit until front glass handle is against top glass front.

STRAIGHT GLASS

E1954-10

PULL HANDLE

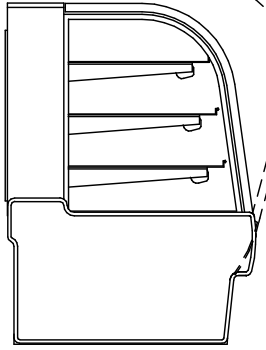

OPEN FRONT GLASS:

1. Stand in front of unit and grab the pull handle with both hands.
2. Pull front glass outward until the glass rests on front glass stops.

CLOSE FRONT GLASS:

1. Stand in front of unit and push on front of pull handle with both hands.
2. Firmly push glass towards rear of unit until front glass rests in closed position

CURVED GLASS

4. The remaining exterior surface should be wiped down using any ammoniated cleaners or soapy warm water.

Note: Detergents are **not** recommended and do not use abrasive cleaners or pads to prevent scratching of surfaces.

WEEKLY CLEANING

This procedure is recommended on a weekly basis. It may need to be performed more often if necessary to maintain a clean, sanitary case. The case should be cleaned to this procedure before using the first time.



NOTICE: Avoid splashing or soaking any electrical components with water to prevent electrical damage to the case.



NOTICE: Shut off light and power switches and remove all product from case. Allow sufficient time for the unit to reach room temperature before proceeding with cleaning.

Interior Cleaning

1. Remove all interior shelving as described in the shelving installation and removal section of this manual.
2. Remove both shelf standards from the interior of case. First remove thumbscrew at bottom of shelf standard and then slide shelf standard up to allow top key slot to clear.

Steps 3 & 4 on refrigerated only.

3. Lift the display pan up and out of evaporator tub. Remove the display pan through rear opening.
4. Remove the evaporator fan shroud. First remove the thumbscrews along the backside of evaporator fan shroud. Lift the rear of the evaporator fan shroud allowing the front to hinge on fan shroud mounting tabs. Reach in and unplug the evaporator fan motor cord. Continue to lift the evaporator

fan shroud while at the same time pulling it to the door opening of case until the slots in the evaporator fan shroud can clear the fan shroud mounting tabs. Remove evaporator fan shroud through rear opening.

5. Clean the entire interior of the case using warm soapy water. Wipe off all soapy water with a damp cloth and allow it to dry.

NOTE: Depending on the amount of usage and spillage of foreign material, some fasteners may have to be removed, and parts disassembled to allow proper cleaning of the unit.

6. Clean all shelves, shelf support bars, shelf light housing, shelf brackets, and display pans using warm soapy water and a brush. Rinse thoroughly and allow it to dry.
7. Clean all foreign material from inner and outer rear door tracks using warm soapy water and a brush. Apply a light film of lubricant such as PAM to make the doors operate smoother.
8. Clean both sides of the doors and interior of the front glass using any common window cleaner. NOTE: Front glass can be tilted forward to simplify front glass cleaning. See "Daily Cleaning" section for glass tilting operation.
9. Reassemble the case in reverse order starting with Step 6.

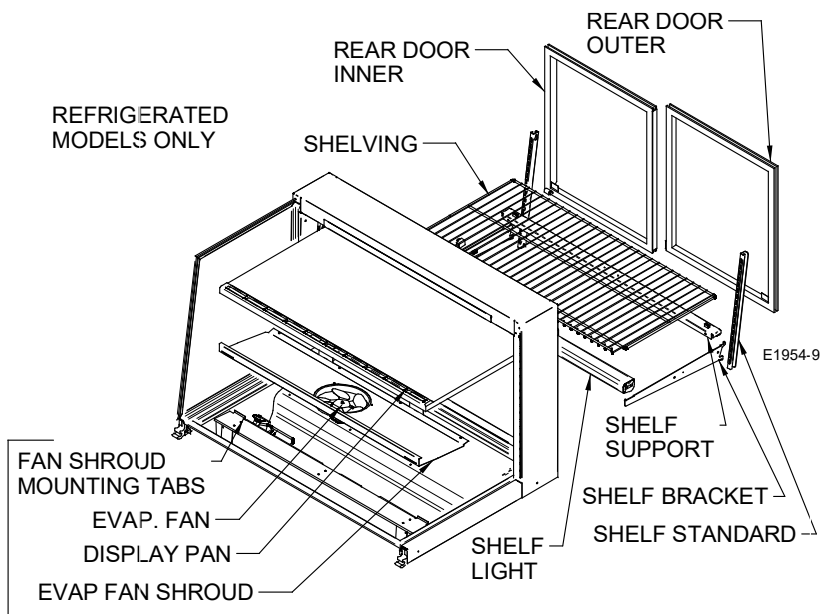

Exterior Cleaning

1. Clean the front glass using any common window cleaner.
2. The exterior surfaces should be wiped down using any ammoniated cleansers or warm soapy water.

NOTE: For major spills or foreign material build-up use complete weekly cleaning instruction.

SERVICE INFORMATION

Fax: (608) 424-3234 Service Information

WARNING
RISK OF ELECTRIC SHOCK

DISCONNECT POWER BEFORE
SERVICING UNIT

Before any service work is performed on the case, make sure all power is disconnected to the case.

IMPORTANT: Read this Section of this manual located on page 6
“REFRIGERATION WARNING & INSTALLATION-REPAIR-DECOMMISSIONING”
All refrigeration and electrical work must be performed by certified technicians.

To find a service company in your area, please visit our website at

<https://federalind.com/support-service/service-rep-locator>.

There you can also find self-service tools to help you get the answers you need faster!

For warranty service requests and all technical support, including compressors and other service parts please contact:

- Phone: (833) 238-8168
- Email: techservice@partstown.com



Federal Industries has partnered with Parts Town for ALL Non-Warranty Part Identification, Pricing, Lead Times, Orders & Freight Quotes. Please contact Parts Town directly if you need parts:

- Website: Partstown.com
- Email: CustomerService@Partstown.com
- Phone: 833-809-8188

PRE-SERVICE CHECKLIST

Case Does Not Operate

Check for disconnected power supply.
Check for tripped breaker or blown fuse.
Check that the thermostat is not “off”.

Lights Do Not Operate

Check that light switch is on.
Be sure light is properly seated in the sockets.
Check that light cord(s) are tight in the sockets.
Plug unused light sockets with socket cap provided with socket.

Case Temperature Too Warm

Check that the cold air inlet and outlet slots are not blocked.
Be sure that the rear doors are closed and tightly sealed.
Check for a blocked or dirty condenser coil filter or condenser coil fins.
Check cold airflow. Lack of adequate cold airflow could be a defective evaporator fan or blocked evaporator coil. Check that paper or foreign material is not blocking evaporator. If the evaporator coil is blocked due to excessive frost, turn the thermostat knob to the “off” position for approximately one hour to defrost. Excessive frost will build up if the case is operated with the door open or ajar.
Check that the display pans are installed properly.

Glass Fogging

Check room ambient – Case is designed to operate in an environment not to exceed 75°F and 55% relative humidity.
Check case temperature – Case is designed to operate between 38°F and 42°F.
Check that nothing is placed on the top of the case glass.

Special Service Situations

There are rare occasions when the refrigerant charge must be evacuated from a case in order to perform service work. In those situations, Federal Industries recommends that the refrigerant charge be evacuated into a recovery system to prevent the possibility of hydrofluorocarbons (HFC's) from being released into the atmosphere.

If moisture or liquid is observed around or under a Federal Industries case, an immediate investigation should be made by qualified personnel to determine the source of the moisture or liquid. The investigation made should determine if the case is malfunctioning or if there is a simple housekeeping problem.

Moisture or liquid around or under a case is a potential slip/fall hazard for persons walking by or working in the general area of the case. Any case malfunction or housekeeping problem that creates a slip/fall hazard around or under a case should be corrected immediately.

SALE & DISPOSAL

IMPORTANT: Read this Section of this manual located on page 6
“REFRIGERATION WARNING & INSTALLATION-REPAIR-DECOMMISSIONING”
All refrigeration and electrical work must be performed by certified technicians

If you, the owner, sells or gives away this Federal Industries case, it is the owner’s responsibility to make sure that all safety labels and the Installation-Service Manual are included with it. If you need replacement labels or manuals, Federal Industries will provide them free of charge. Contact the customer service department at Federal Industries at (800) 356-4206.

The customer service department at Federal Industries should be contacted at the time of sale or disposal of your case so records may be kept of its new location.

If you sell or give away your Federal Industries case, you should evacuate the refrigerant charge before shipment. Federal Industries recommends that the charge be evacuated into a recovery system to prevent the possibility of HFO’s from being released into the atmosphere.

REFRIGERANT RECOVERY/RECYCLING/DISPOSAL

When recycling or discarding case, refrigerants **MUST BE** handled according to local, state and federal codes, requirements and regulations.

If disposing of a refrigerated case that uses ozone depleting chemicals in its refrigeration system, make sure the refrigerant is removed by a qualified service technician and properly disposed of.

If you intentionally release refrigerant into the atmosphere, you may be subject to fines or other penalties (under regulation mandated by environmental regulators and/or legislative edict.)

OWNER RESPONSIBILITY

If you sell or give away your Federal Industries case, you must make sure that all safety labels and the Installation-Service Manual are included with it. If you need replacement labels or manuals, Federal Industries will provide them free of charge. Contact the customer service department at Federal Industries at (800) 356-4206.

The customer service department at Federal Industries should be contacted at the time of sale or disposal of your case so records may be kept of its new location.

If you sell or give away your Federal Industries case and you evacuate the refrigerant charge before shipment. Federal Industries recommends that the charge be evacuated into a recovery system to prevent the possibility of HFC’s from being released into the atmosphere.

REMOTE REFRIGERATION

ELECTRONIC EXPANSION VALVE (EEV) ON REMOTE CASES ONLY

A traditional TXV uses springs and a temperature bulb to open and close a valve port that controls the flow of refrigerant entering the evaporator coil. An electronic expansion valve (EEV) controls the refrigerant flow much more precisely, increasing the performance and efficiency of the refrigeration system. The EEV controls the flow of Refrigerant by opening and closing the valve port based on the response to signals sent to the EEV by an electronic controller. The electronic Control bases these signals by processing information provided from a temperature sensor and pressure transducer located on the discharge side of the evaporator coil.

These sensors monitor the evaporator superheat and protects the compressor from any liquid flood back under low superheat conditions.

EEV Controller Settings

The electronic expansion valve controller also allows the use of different types of refrigerants without the need to change the expansion valve.





The controller is set from the factory to run on 449A refrigerant and will not need any changes to the control unless another refrigerant is used.

Note: Check your State and Local regulations for approved refrigerants for your install location. Federal Industries is not liable for any alternate refrigerants used.

The control is located in the base of the case to the left of the electrical connection box.

Note: Never change any of the other setting other than the refrigerant type. It may also be necessary to change the superheat setting only when using a different refrigerant.



Indicator lights	
	Red light - critical alarm (system is NOT running)
	Yellow light - non-critical alarm (system running)
	Green light - compressor on
	Green blinking - compressor waiting on timer to start/stop

Changing Refrigerant

- Access the set point mode by pressing and holding the **ENTER** button until Ctl displays on the screen.
- Use the **▲** up or **▼** down arrows to advance through the available set points until rFG displays on the screen and press the **ENTER** button.
- Use the **▲** up or **▼** down arrows until the desired refrigeration displays on the screen and press and hold the **ENTER** button until rFG once again displays on the screen.
- Press the **BACK** to return to escape the settings menu.

Changing Superheat

- Access the set point mode by pressing and holding the **ENTER** button until Ctl displays on the screen.
- Use the **▲** up or **▼** down arrows to advance through the available set points until SSP displays on the screen and press the **ENTER** button.
- Use the **▲** up or **▼** down arrows to set the desired superheat displays on the screen and press and hold the **ENTER** button until SSP once again displays on the screen.
- Press the **BACK** to return to escape the settings menu.

MAIN WIRING DIAGRAMS

120 VOLT DRY

MAIN WIRING DIAGRAM DETAIL

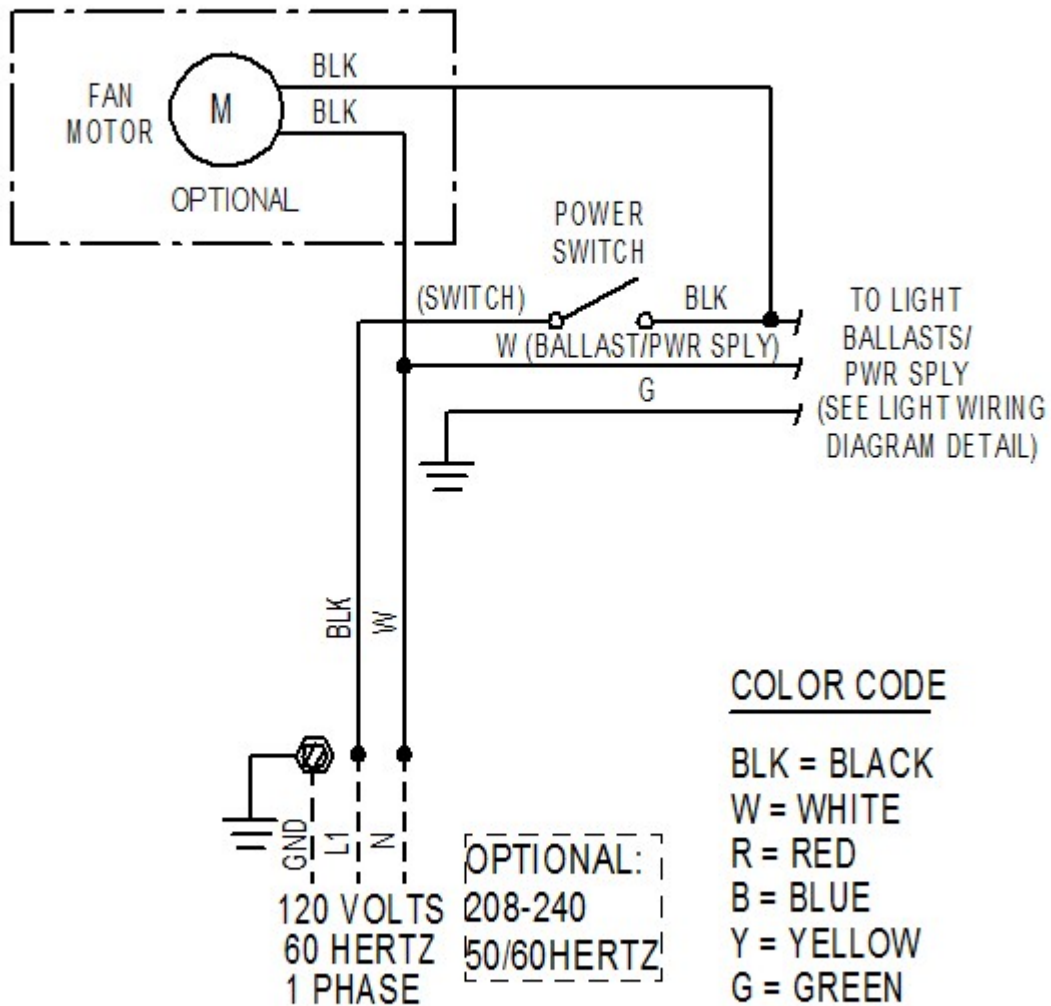

91-14145 12/19/18

120 VOLT REFRIGERATED SELF CONTAINED

MAIN WIRING DIAGRAM DETAIL

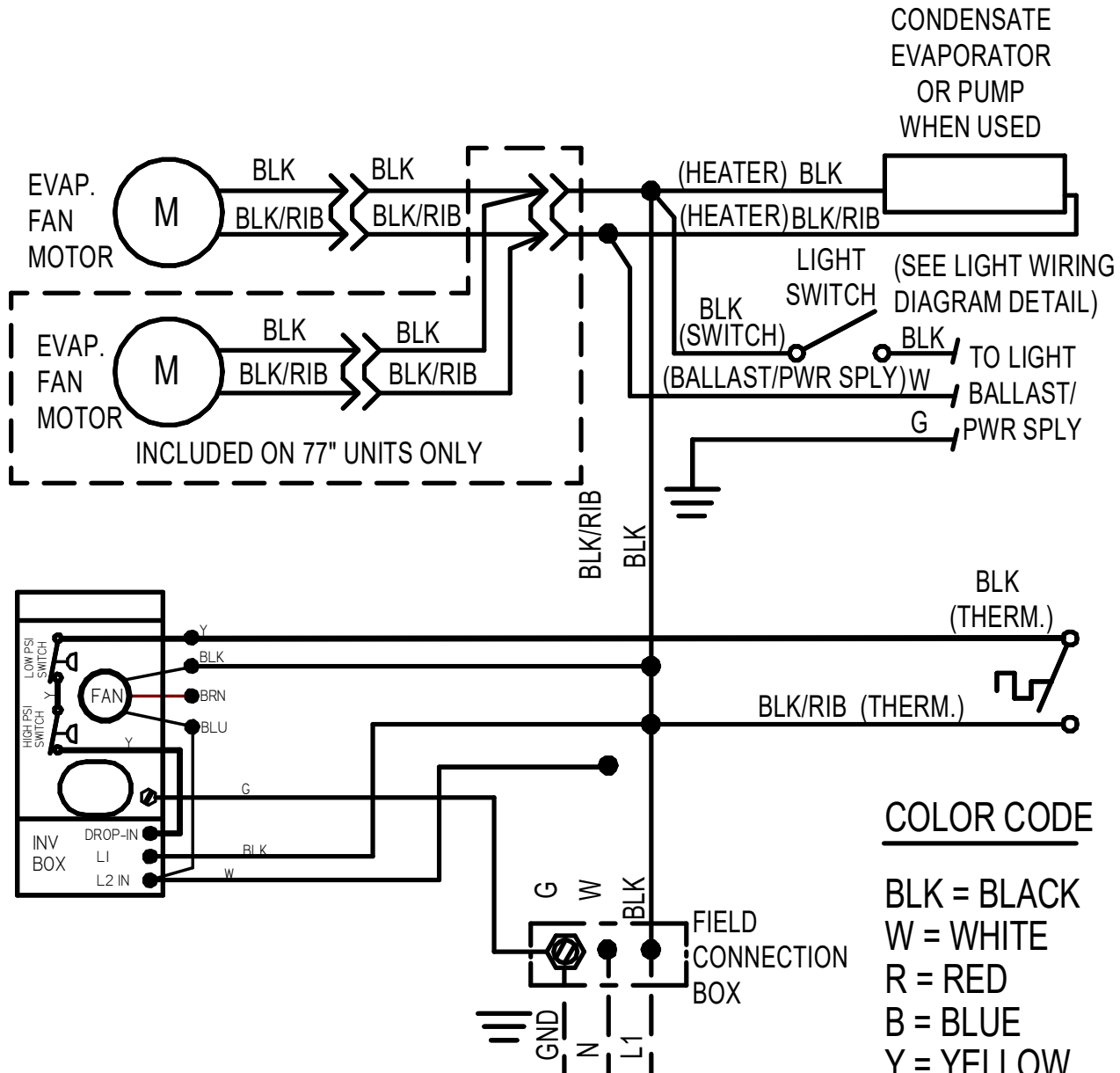

COLOR CODE

- BLK = BLACK
- W = WHITE
- R = RED
- B = BLUE
- Y = YELLOW
- G = GREEN

120 VOLTS, 60 HERTZ, 1 PHASE
UNIT MUST BE GROUNDED

91-14146-10 3/18/25

LED LIGHT WIRING DIAGRAMS W/HEATER

All models with standard LED shelf lights except DZH models

LIGHT WIRING DIAGRAM DETAIL

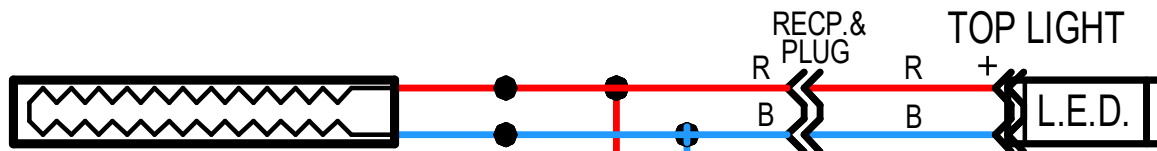

24V. ANTI SWEAT HEATER
(1) PER EA. REFRIGERATED CASE

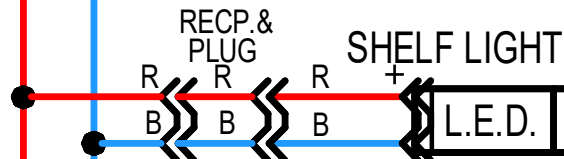
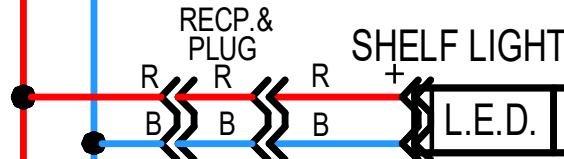
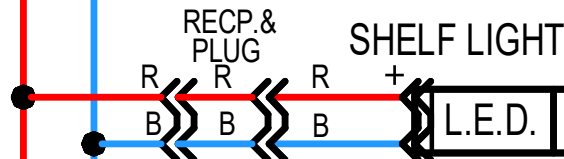
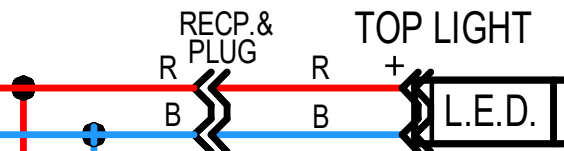

TYPICAL: SHELF LIGHT
QUANTITY MAY VARY

DZ CASES USE (2)
DUPLICATE LIGHT
CIRCUITS AS SHOWN

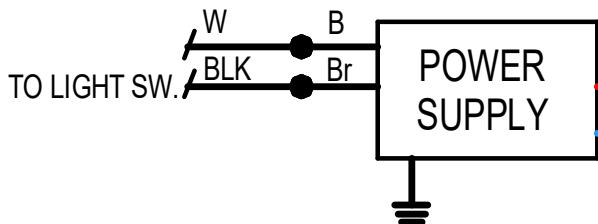

COLOR CODE: Br = BROWN
BLK = BLACK B = BLUE
W = WHITE Y = YELLOW
R = RED G = GREEN

(SEE MAIN WIRING DIAGRAM DETAIL)

91-21026 REV B 01/23/24

REPLACEMENT PARTS

SELF CONTAINED REFRIGERATION SYSTEM (REFRIGERATED CASES ONLY)

REFRIGERATED MODELS		CONDENSING UNIT/SC120V	EVAP. COIL	EXPANSION VALVE	EVAPORATOR FAN W/BLADE	THERM- OSTAT	CONDENSER AIR FILTER	ANTI SWEAT HEATER
CGR3642	SGR3642	30-21754	33-13356	32-21751	41-21237-16	32-51012	16-13647	43-21632-1
CGR3648	SGR3648	30-21754	33-13356	32-21751	41-21237-16	32-51012	16-13647	43-21632-1
CGR5042	SGR5042	30-21754	33-13357	32-21750	41-21237-16	32-51012	16-13647	43-21632-2
CGR5048	SGR5048	30-21754	33-13357	32-21750	41-21237-16	32-51012	16-13647	43-21632-2
CGR5942	SGR5942	30-21754	33-13358	32-21750	41-21237-16	32-51012	16-13647	43-21632-3
CGR5948	SGR5948	30-21754	33-13358	32-21750	41-21237-16	32-51012	16-13647	43-21632-3
CGR7742	SGR7742	30-21754	33-13359	32-21750	41-21237-16	32-51012	16-13647	43-21632-4
CGR7748	SGR7748	30-21754	33-13359	32-21750	41-21237-16	32-51012	16-13647	43-21632-4
CGR5042DZ	SGR5042DZ	30-21754	33-13354	32-21751	41-21237-16	32-51012	16-13647	43-21632
CGR5048DZ	SGR5048DZ	30-21754	33-13354	32-21751	41-21237-16	32-51012	16-13647	43-21632
CGR5942DZ	SGR5942DZ	30-21754	33-13355	32-21751	41-21237-16	32-51012	16-13647	43-21632-1
CGR5948DZ	SGR5948DZ	30-21754	33-13355	32-21751	41-21237-16	32-51012	16-13647	43-21632-1
CGR7742DZ	SGR7742DZ	30-21754	33-13356	32-21751	41-21237-16	32-51012	16-13647	43-21632-2
CGR7748DZ	SGR7748DZ	30-21754	33-13356	32-21751	41-21237-16	32-51012	16-13647	43-21632-2
CGR5048CD	SGR5048CD	30-21754	33-13357	32-21750	41-21237-16	32-51012	16-13647	43-21632-2
CGR5948CD	SGR5948CD	30-21754	33-13358	32-21750	41-21237-16	32-51012	16-13647	43-21632-3
CGR7748CD	SGR7748CD	30-21754	33-13358	32-21750	41-21237-16	32-51012	16-13647	43-21632-4

SELF CONTAINED REFRIGERATION SYSTEM (REFRIGERATED CASES ONLY)

REMOTE REFRIGERATED MODELS		EVAP COIL	ELECTRONIC EXPANSION VALVE (EEV)	EEV CONTROL	TEMP SENSOR	PRESSURE TRANS-DUCER	EVAPORATOR MOTOR/WBLADE	THERMO-STAT	CONDENSATE PAN
CGR3642R	SGR3642R	33-13356	32-21228	32-21223	32-21224	32-21225	4I-21237-16	32-15495	40-20420
CGR3648R	SGR3648R	33-13356	32-21228	32-21223	32-21224	32-21225	4I-21237-16	32-15495	40-20420
CGR5042R	SGR5042R	33-13357	32-21228	32-21223	32-21224	32-21225	4I-21237-16	32-15495	40-20420
CGR5048R	SGR5048R	33-13357	32-21228	32-21223	32-21224	32-21225	4I-21237-16	32-15495	40-20420
CGR5942R	SGR5942R	33-13358	32-21228	32-21223	32-21224	32-21225	4I-21237-16	32-15495	40-20421
CGR5948R	SGR5948R	33-13358	32-21228	32-21223	32-21224	32-21225	4I-21237-16	32-15495	40-20421
CGR7742R	SGR7742R	33-13359	32-21228	32-21223	32-21224	32-21225	4I-21237-16	32-15495	40-20421
CGR7748R	SGR7748R	33-13359	32-21228	32-21223	32-21224	32-21225	4I-21237-16	32-15495	40-20421
CGR5042DZR	SGR5042DZR	33-13354	32-21228	32-21223	32-21224	32-21225	4I-21237-16	32-15495	40-20420
CGR5048DZR	SGR5048DZR	33-13354	32-21228	32-21223	32-21224	32-21225	4I-21237-16	32-15495	40-20420
CGR5942DZR	SGR5942DZR	33-13355	32-21228	32-21223	32-21224	32-21225	4I-21237-16	32-15495	40-20421
CGR5948DZR	SGR5948DZR	33-13355	32-21228	32-21223	32-21224	32-21225	4I-21237-16	32-15495	40-20421
CGR7742DZR	SGR7742DZR	33-13356	32-21228	32-21223	32-21224	32-21225	4I-21237-16	32-15495	40-20421
CGR7748DZR	SGR7748DZR	33-13356	32-21228	32-21223	32-21224	32-21225	4I-21237-16	32-15495	40-20421
CGR5048CDR	SGR5048CDR	33-13357	32-21228	32-21223	32-21224	32-21225	4I-21237-16	32-15495	40-20420
CGR5948CDR	SGR5948CDR	33-13358	32-21228	32-21223	32-21224	32-21225	4I-21237-16	32-15495	40-20421
CGR7748CDR	SGR7748CDR	33-13358	32-21228	32-21223	32-21224	32-21225	4I-21237-16	32-15495	40-20421

ELECTRICAL COMPONENTS

GLASS COMPONENTS

ELECTRICAL COMPONENTS		MODEL (INCLUDING REMOTES)	LIGHT SWITCH	LED POWER SUPPLY	LED LIGHT	TOP LIGHT CORD	SHELF LIGHT CORD	SHELF LIGHT CORD CLIP	30° LED LIGHT CLIP	SHELF LIGHT RECEPTACLE HARNESS	TOP & SHELF LIGHT WIRE HARNESS	LIGHT WIRING DIAGRAM	SC MAIN WIRING DIAGRAM	REM. MAIN WIRING DIAGRAM
CGR3642	SGD3642	41-11066	39-20986	42-20871-25C30	43-20860-1W	43-20862-6W	67-20952	67-20869-30	43-20996-W	43-21005	91-21026	91-14146-10	N/A	
CGR3642	SGR3642	41-11066	39-20986	42-20871-25C30	43-20860-1W	43-20862-6W	67-20952	67-20869-30	43-20996-W	43-21005	91-21026	91-14146-10	91-14147	
CGR3642CD	SGR3642CD	41-11066	39-20986	42-20871-25C30	43-20860-1W	43-20862-6W	67-20952	67-20869-30	43-20996-W	43-21005	91-21026	91-14146-10	91-14147	
CGR3648	SGD3648	41-11066	39-20986	42-20871-25C30	43-20860-1W	43-20862-6W	67-20952	67-20869-30	43-20996-W	43-21005	91-21026	91-14146-10	N/A	
CGR3648	SGR3648	41-11066	39-20986	42-20871-25C30	43-20860-1W	43-20862-6W	67-20952	67-20869-30	43-20996-W	43-21005	91-21026	91-14146-10	91-14147	
CGR3648CD	SGR3648CD	41-11066	39-20986	42-20871-25C30	43-20860-1W	43-20862-6W	67-20952	67-20869-30	43-20996-W	43-21005	91-21026	91-14146-10	91-14147	
CGR5042	SGD5042	41-11066	39-20986	42-20871-42C30	43-20860-1W	43-20862-6W	67-20952	67-20869-30	43-20996-W	43-21005	91-21026	91-14146-10	N/A	
CGR5042	SGR5042	41-11066	39-20986	42-20871-42C30	43-20860-1W	43-20862-6W	67-20952	67-20869-30	43-20996-W	43-21005	91-21026	91-14146-10	91-14147	
CGR5042CD	SGR5042CD	41-11066	39-20986	42-20871-42C30	43-20860-1W	43-20862-6W	67-20952	67-20869-30	43-20996-W	43-21005	91-21026	91-14146-10	91-14147	
CGR5042DZ	SGR5042DZ	41-11066	39-20986	42-20871-20C30	43-20860-1W	43-20862-6W	67-20952	67-20869-30	43-20996-W	43-21005	91-21026	91-14146-10	91-14147	
CGR5048	SGD5048	41-11066	39-20986	42-20871-42C30	43-20860-1W	43-20862-6W	67-20952	67-20869-30	43-20996-W	43-21005	91-21026	91-14146-10	N/A	
CGR5048	SGR5048	41-11066	39-20986	42-20871-42C30	43-20860-1W	43-20862-6W	67-20952	67-20869-30	43-20996-W	43-21005	91-21026	91-14146-10	91-14147	
CGR5048CD	SGR5048CD	41-11066	39-20986	42-20871-42C30	43-20860-1W	43-20862-6W	67-20952	67-20869-30	43-20996-W	43-21005	91-21026	91-14146-10	91-14147	
CGR5048DZ	SGR5048DZ	41-11066	39-20986	42-20871-20C30	43-20860-1W	43-20862-6W	67-20952	67-20869-30	43-20996-W	43-21005	91-21026	91-14146-10	91-14147	
CGR5942	SGD5942	41-11066	39-20986	42-20871-54C30	43-20860-1W	43-20862-6W	67-20952	67-20869-30	43-20996-W	43-21005	91-21026	91-14146-10	N/A	
CGR5942	SGR5942	41-11066	39-20986	42-20871-54C30	43-20860-1W	43-20862-6W	67-20952	67-20869-30	43-20996-W	43-21005	91-21026	91-14146-10	91-14147	
CGR5942CD	SGR5942CD	41-11066	39-20986	42-20871-54C30	43-20860-1W	43-20862-6W	67-20952	67-20869-30	43-20996-W	43-21005	91-21026	91-14146-10	91-14147	
CGR5942DZ	SGR5942DZ	41-11066	39-20986	42-20871-24C30	43-20860-1W	43-20862-6W	67-20952	67-20869-30	43-20996-W	43-21005	91-21026	91-14146-10	91-14147	
CGR5948	SGD5948	41-11066	39-20986	42-20871-54C30	43-20860-1W	43-20862-6W	67-20952	67-20869-30	43-20996-W	43-21005	91-21026	91-14146-10	N/A	
CGR5948	SGR5948	41-11066	39-20986	42-20871-54C30	43-20860-1W	43-20862-6W	67-20952	67-20869-30	43-20996-W	43-21005	91-21026	91-14146-10	91-14147	
CGR5948CD	SGR5948CD	41-11066	39-20986	42-20871-54C30	43-20860-1W	43-20862-6W	67-20952	67-20869-30	43-20996-W	43-21005	91-21026	91-14146-10	91-14147	
CGR5948DZ	SGR5948DZ	41-11066	39-20986	42-20871-24C30	43-20860-1W	43-20862-6W	67-20952	67-20869-30	43-20996-W	43-21005	91-21026	91-14146-10	91-14147	
CGR7742	SGD7742	41-11066	39-20555	42-20871-72C30	43-20860-1W	43-20862-6W	67-20952	67-20869-30	43-20996-W	43-21005	91-21026	91-14146-10	N/A	
CGR7742	SGR7742	41-11066	39-20555	42-20871-72C30	43-20860-1W	43-20862-6W	67-20952	67-20869-30	43-20996-W	43-21005	91-21026	91-14146-10	91-14147	
CGR7742CD	SGR7742CD	41-11066	39-20555	42-20871-72C30	43-20860-1W	43-20862-6W	67-20952	67-20869-30	43-20996-W	43-21005	91-21026	91-14146-10	91-14147	
CGR7742DZ	SGR7742DZ	41-11066	39-20986	42-20871-30C30	43-20860-1W	43-20862-6W	67-20952	67-20869-30	43-20996-W	43-21005	91-21026	91-14146-10	91-14147	
CGR7748	SGD7748	41-11066	39-20555	42-20871-72C30	43-20860-1W	43-20862-6W	67-20952	67-20869-30	43-20996-W	43-21005	91-21026	91-14146-10	N/A	
CGR7748	SGR7748	41-11066	39-20555	42-20871-72C30	43-20860-1W	43-20862-6W	67-20952	67-20869-30	43-20996-W	43-21005	91-21026	91-14146-10	91-14147	
CGR7748CD	SGR7748CD	41-11066	39-20555	42-20871-72C30	43-20860-1W	43-20862-6W	67-20952	67-20869-30	43-20996-W	43-21005	91-21026	91-14146-10	91-14147	
CGR7748DZ	SGR7748DZ	41-11066	39-20986	42-20871-30C30	43-20860-1W	43-20862-6W	67-20952	67-20869-30	43-20996-W	43-21005	91-21026	91-14146-10	91-14147	

GLASS COMPONENTS												
MODELS	CURVED	END GLASS	END GLASS	END GLASS	END GLASS	END GLASS	FRONT	TOP	END GLASS	END GLASS	END GLASS	DZ CENTER
BALL)	FRONT GLASS	CLEAR	MIRROR L.H.	MIRROR R.H.	MIRROR L.H.	MIRROR R.H.	GLASS	GLASS	CLEAR	MIRROR L.H.	MIRROR R.H.	MIRROR
CGD3148	50-13396	51-13473	51-14404-L	51-14404-R	N/A	N/A	51-13427	51-13428	51-13444	51-14408-L	51-14408-R	N/A
CGR3148	50-13386	51-13471	51-14402-L	51-14402-R	N/A	N/A	51-13405	51-13406	51-13422	51-13402-L	51-13402-R	N/A
CGD3642	50-13392	51-13472	51-14403-L	51-14403-R	N/A	N/A	51-13425	51-13426	51-13443	51-14407-L	51-14407-R	N/A
CGR3642	50-13382	51-13470	51-14401-L	51-14401-R	N/A	N/A	51-13403	51-13404	51-13421	51-13401-L	51-13401-R	N/A
CGD3648	50-13397	51-13473	51-14404-L	51-14404-R	N/A	N/A	51-13429	51-13430	51-13444	51-14408-L	51-14408-R	N/A
CGR3648	50-13387	51-13471	51-14402-L	51-14402-R	N/A	N/A	51-13407	51-13408	51-13422	51-13402-L	51-13402-R	N/A
CGD5042	50-13393	51-13472	51-14403-L	51-14403-R	N/A	N/A	51-13431	51-13432	51-13443	51-14407-L	51-14407-R	N/A
CGR5042	50-13383	51-13470	51-14401-L	51-14401-R	N/A	N/A	51-13409	51-13410	51-13421	51-13401-L	51-13401-R	N/A
CGR5042DZ	50-13383	51-13470	51-14401-L	51-14401-R	51-13423	51-13423	51-13409	51-13410	51-13421	51-13401-L	51-13401-R	51-14287
CGD5048	50-13398	51-13473	51-14404-L	51-14404-R	N/A	N/A	51-13433	51-13434	51-13444	51-14408-L	51-14408-R	N/A
CGR5048	50-13388	51-13471	51-14402-L	51-14402-R	N/A	N/A	51-13411	51-13412	51-13422	51-13402-L	51-13402-R	N/A
CGR5048CD	50-13388	51-13471	51-14402-L	51-14402-R	N/A	N/A	51-13411	51-13412	51-13422	51-13402-L	51-13402-R	N/A
CGR5048DZ	50-13388	51-13471	51-14402-L	51-14402-R	51-13424	51-13424	51-13411	51-13412	51-13422	51-13402-L	51-13402-R	51-14290
CGD5942	50-13394	51-13472	51-14403-L	51-14403-R	N/A	N/A	51-13435	51-13436	51-13443	51-14407-L	51-14407-R	N/A
CGR5942	50-13384	51-13470	51-14401-L	51-14401-R	N/A	N/A	51-13413	51-13414	51-13421	51-13401-L	51-13401-R	N/A
CGR5942DZ	50-13384	51-13470	51-14401-L	51-14401-R	51-13423	51-13423	51-13413	51-13414	51-13421	51-13401-L	51-13401-R	51-14287
CGD5948	50-13399	51-13473	51-14404-L	51-14404-R	N/A	N/A	51-13437	51-13438	51-13444	51-14408-L	51-14408-R	N/A
CGR5948	50-13389	51-13471	51-14402-L	51-14402-R	N/A	N/A	51-13415	51-13416	51-13422	51-13402-L	51-13402-R	N/A
CGR5948CD	50-13389	51-13471	51-14402-L	51-14402-R	N/A	N/A	51-13415	51-13416	51-13422	51-13402-L	51-13402-R	N/A
CGR5948DZ	50-13389	51-13471	51-14402-L	51-14402-R	51-13424	51-13424	51-13415	51-13416	51-13422	51-13402-L	51-13402-R	51-14290
CGD7742	50-13395	51-13472	51-14403-L	51-14403-R	N/A	N/A	51-13439	51-13440	51-13443	51-14407-L	51-14407-R	N/A
CGR7742	50-13385	51-13470	51-14401-L	51-14401-R	N/A	N/A	51-13417	51-13418	51-13421	51-13401-L	51-13401-R	N/A
CGR7742DZ	50-13385	51-13470	51-14401-L	51-14401-R	51-13423	51-13423	51-13417	51-13418	51-13421	51-13401-L	51-13401-R	51-14287
CGD7748	50-13400	51-13473	51-14404-L	51-14404-R	N/A	N/A	51-13441	51-13442	51-13444	51-14408-L	51-14408-R	N/A
CGR7748	50-13390	51-13471	51-14402-L	51-14402-R	N/A	N/A	51-13419	51-13420	51-13422	51-13402-L	51-13402-R	N/A
CGR7748CD	50-13390	51-13471	51-14402-L	51-14402-R	N/A	N/A	51-13419	51-13420	51-13422	51-13402-L	51-13402-R	N/A
CGR7748DZ	50-13390	51-13471	51-14402-L	51-14402-R	51-13424	51-13424	51-13419	51-13420	51-13422	51-13402-L	51-13402-R	51-14288
CGR7748DZ	50-13390	51-13471	51-14402-L	51-14402-R	51-13424	51-13424	51-13419	51-13420	51-13422	51-13402-L	51-13402-R	51-14288

DOOR & SHELF COMPONENTS

DOOR & SHELF COMPONENTS													
MODELS	DOOR LEFT CLEAR	DOOR RIGHT CLEAR	DOOR LEFT REFLECTIVE	DOOR RIGHT REFLECTIVE	WIRE SHELF WHITE	WIRE SHELF ZINK PLATED	WIRE SHELF CLIP	GLASS SHELF HOLDER	STAINLESS SHELF	SHELF BRACKET			
CGR3642	SGD3642	53-13666	53-13667	53-13682	53-13683	63-13813	63-14304	81-30618	52-14902	SA2964-I			
CGR3642	SGR3642	53-13666	53-13667	53-13682	53-13683	63-13813	63-14304	81-30618	52-14902	SA2964-I			
CGR3648	SGD3648	53-13674	53-13675	53-13690	53-13691	63-13813	63-14304	81-30618	52-14902	SA2964-I			
CGR3648	SGR3648	53-13674	53-13675	53-13690	53-13691	63-13813	63-14304	81-30618	52-14902	SA2964-I			
CGR5042	SGD5042	53-13668	53-13669	53-13684	53-13685	63-13815	63-14606	81-30618	52-14899	SA2964-I			
CGR5042	SGR5042	53-13668	53-13669	53-13684	53-13685	63-13815	63-14606	81-30618	52-14899	SA2964-I			
CGR5042DZ	SGR5042DZ	53-13668	53-13669	53-13684	53-13685	63-13811	63-14302	81-30618	52-14898	SA2964-I			
CGR5048	SGD5048	53-13676	53-13677	53-13692	53-13693	63-13815	63-14606	81-30618	52-14898	SA2964-I			
CGR5048	SGR5048	53-13676	53-13677	53-13692	53-13693	63-13815	63-14606	81-30618	52-14898	SA2964-I			
CGR5048CD	SGR5048CD	53-13676	53-13677	53-13692	53-13693	N/A	N/A	N/A	MII558-I	67-14293			
CGR5048DZ	SGR5048DZ	53-13676	53-13677	53-13692	53-13693	63-13811	63-14302	81-30618	52-14898	SA2964-I			
CGR5942	SGD5942	53-13670	53-13671	53-13686	53-13687	63-13816	63-14307	81-30618	52-14901	SA2964-I			
CGR5942	SGR5942	53-13676	53-13677	53-13692	53-13693	63-13816	63-14307	81-30618	52-14901	SA2964-I			
CGR5942DZ	SGR5942DZ	53-13676	53-13677	53-13692	53-13693	63-13812	63-14303	81-30618	52-14900	SA2964-I			
CGR5948	SGD5948	53-13678	53-13679	53-13694	53-13695	63-13816	63-14307	81-30618	52-14901	SA2964-I			
CGR5948	SGR5948	53-13676	53-13677	53-13692	53-13693	63-13816	63-14307	81-30618	52-14901	SA2964-I			
CGR5948CD	SGR5948CD	53-13676	53-13677	53-13692	53-13693	N/A	N/A	N/A	MII558-2	67-14293			
CGR5948DZ	SGR5948DZ	53-13676	53-13677	53-13692	53-13693	63-13812	63-14303	81-30618	52-14900	SA2964-I			
CGR7742	SGD7742	53-13672	53-13673	53-13688	53-13689	63-13817	63-14308	81-30618	52-14904	SA2964-I			
CGR7742	SGR7742	53-13672	53-13673	53-13688	53-13689	63-13817	63-14308	81-30618	52-14904	SA2964-I			
CGR7742DZ	SGR7742DZ	53-13672	53-13673	53-13688	53-13689	63-13814	63-14305	81-30618	52-14903	SA2964-I			
CGR7748	SGD7748	53-13680	53-13681	53-13696	53-13697	63-13817	63-14308	81-30618	52-14904	SA2964-I			
CGR7748	SGR7748	53-13680	53-13681	53-13696	53-13697	63-13817	63-14308	81-30618	52-14904	SA2964-I			
CGR7748CD	SGR7748CD	53-13680	53-13681	53-13696	53-13697	N/A	N/A	N/A	MII558-3	67-14293			
CGR7748DZ	SGR7748DZ	53-13680	53-13681	53-13696	53-13697	63-13814	63-14305	81-30618	52-14903	SA2964-I			

California Residents Only.

 **WARNING**

This product can expose you to chemicals including chromium which is known to the State of California to cause cancer and birth defects or other reproductive harm. For more information go to

www.P65Warnings.ca.gov