

E2660-20

Rev. A Revised 2/5/25

INSTALLATION & OPERATIONS INSTRUCTIONS
*Self-Contained & Remote Refrigerated Models
& Non-Refrigerated Counter Displays
(Service & Self-Serve)*



KEEP THIS MANUAL FOR FUTURE REFERENCE

Engineering and technical data are subject to change without notice.

FEDERAL INDUSTRIES
Toll Free 1(800) 356-4206

215 Federal Avenue
WI Phone (608) 424-3331

Belleville, WI 53508
Fax: (608) 424-3234

CONTENTS

INTRODUCTION	3
WARNING LABELS & SAFETY INSTRUCTIONS	4
REFRIGERATION WARNING (INSTALL-REPAIR-DECOMMISSIONING)	5-9
PRE-INSTALLATION PROCEDURES	10
Inspection For Shipping Damage.....	10
GENERAL ELECTRICAL & GROUNDING	10
INSTALLATION INSTRUCTIONS	10
Locating The Display Case.....	11
Removing Case From Shipping Skid & General Installation.....	11
Cleaning.....	11
<u>Dry CD Model Installation</u>	11
Cabinet Preparation.....	11
Cord Options.....	12
<u>Refrigerated CRR Self Contained Model Installation</u>	12
Cabinet Preparation.....	12
Cord Options.....	13
<u>Refrigerated CRB Self Contained Model Installation</u>	13
Cabinet Preparation.....	13
Cord Options.....	14
<u>Refrigerated CRR Remote Model Installation</u>	15
Cabinet Preparation.....	15
Cord Options.....	15
Connect Remote Refrigeration Lines & Evaporator Condensate Drain.....	16
<u>Refrigerated CRB Remote Model Installation</u>	16
Cabinet Preparation.....	16
Cord Options.....	16
Connect Refrigeration Lines.....	17
<u>Refrigeration Installation (Refrigerated units)</u>	17
Self Contained Models.....	17
Remote Models.....	17
<u>Case Line Up Installation</u>	18
Top Joining Bracket.....	18
Bottom Pedestal Joining.....	19
END PANEL INSTALLATION	20
SHELVING INSTALLATION & REMOVAL	21
Shelf Brackets & Supports.....	21
Shelves and shelf light quantity.....	22
Wire Shelf Installation.....	22
Glass Shelf Installation.....	22
Metal Shelf Installation.....	23
DOOR REMOVAL INSTRUCTION	24
OPERATING INSTRUCTIONS	25
Controls.....	25
Shelves.....	25
Rear Package Shelf.....	25
Placing Product Into Case / Self-Serve Max. Run Timer Settings.....	25
Electronic Expansion Valve.....	26
MAINTENANCE	27
Shelf Light Replacement.....	28
Top Light Replacement (All Service and Dry Self-Serve).....	28
Top Light Replacement (Refrigerated Self-Serve).....	28
PERIODIC MAINTENANCE	28
Cleaning Condenser Coil.....	28
CLEANING INSTRUCTIONS	28
Daily Cleaning.....	28
Weekly Cleaning.....	29
SERVICE INFORMATION	31
Pre-Service Checklist.....	31
Special Service Situations.....	32
SALE & DISPOSAL	32
Owner Responsibility.....	32
REFRIGERATION & ELECTRICAL DATA	33
WIRING DIAGRAMS	34-37
PARTS	38-39

INTRODUCTION

Thank you for purchasing a Federal Industries display case. This manual contains important instructions for installing and servicing the Curved Glass and Hi-Volume Refrigerated (including Dual Zone & Cold Deli) and Non-Refrigerated Display Cases. A repair parts list and wiring diagram are also included in the manual. Read all of these documents carefully before installing or servicing your case.



NOTICE

Read this manual before installing your case. Keep this manual and refer to it before doing any service on the equipment. Failure to do so could result in personal injury or damage to the case.



NOTICE

Installation and service of the electrical components in the case must be performed by a licensed electrician.

The portions of this manual covering components contain technical instructions intended only for persons qualified to perform electrical work.



DANGER

Improper or faulty hookup of electrical components in the case can result in severe injury or death.

All electrical wiring hookups must be done in accordance with all applicable local, regional, or national standards.

SERIAL NUMBER

Record the model and serial numbers of the case for easy reference. Always refer to both model and serial numbers in your correspondence regarding the case.

Case Model _____ Serial Number _____
Condensing Unit Model _____ Serial Number _____

This manual cannot cover every installation, use, or service situation. If you need additional information, call or write us:

WARRANTY/TECHNICAL SERVICE DEPARTMENT

Federal Industries
215 Federal Avenue
Belleville, WI 53508

Toll Free (800) 356-4206 / WI Phone (608) 424-3331

WARNING LABELS & SAFETY INSTRUCTIONS

 This is the safety-alert symbol. When you see this symbol on your case or in the manual, be alert to the potential for personal injury or damage to your equipment.

Be sure you understand all safety messages and always follow recommended precautions and safe operating procedures.

NOTICE TO EMPLOYERS

You must make sure that everyone who installs, uses, or services your case is thoroughly familiar with all safety information and procedures.

Important safety information is presented in this section and throughout the manual. The following signal words are used in the warning and safety messages:

DANGER: Severe injury or death **will** occur if you ignore the message.

WARNING: Severe injury or death **can** occur if you ignore the message.

CAUTION: Minor injury or damage to your case **can** occur if you ignore the message.

NOTICE: This is important installation, operation, or service information. If you ignore the message, you may damage your case.

The warning and safety labels shown throughout this manual are placed on your Federal Industries case at the factory. Follow all warning label instructions. If any warning or safety labels become lost or damaged, call our customer service department at 1(800) 356-4206 for replacements.

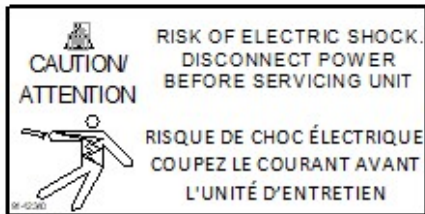

This label is located behind the removable base display and under deck pans.



This label is located under display deck panels

DANGER – Risk of fire or explosion. Flammable refrigerant used. Consult repair manual/owner's guide before attempting to service this product. all safety precautions must be followed

91-21814

DANGER — Risque d'incendie ou d'explosion. Fluide frigorigène utilisé. Consulter le guide propriétaire ou le manuel de réparations avant de d'essayer d'installer ou de réparer ce produit. Toutes les précautions de sécurité doivent être suivies.

91-21814

This label is located by condensing unit

REFRIGERANT WARNINGS



This is the Danger-Flammable symbol. When you see this symbol on your case or in the manual, be alert to the potential for risk of fire or explosion.

Be sure you understand all safety messages and always follow recommended precautions and safe operating procedures.

DANGER



Risk of fire or explosion. Flammable refrigerant used. To be repaired only by trained service personnel. Do not puncture refrigerant tubing. Dispose of properly in accordance with federal or local regulations. Flammable refrigerant used.

Consult repair manual/owner's guide before attempting to service this product. All safety precautions must be followed.

Follow handling instructions carefully in compliance with national regulations.

Auxiliary devices which may be ignition sources shall not be installed in the ductwork, other than auxiliary devices listed for use with the specific appliance.

Do not store explosive substances (such as aerosol cans with a flammable propellant) in this case.

Do not use an electrical appliance INSIDE the food storage compartments unless its type is recommended by manufacturer.

Flammable refrigerant type specified on case nameplate is on the serial label.

APPLIES TO R290 REFRIGERANT MODELS ONLY! Contains a charge of R290 refrigerant with a lower flammability limit (LFL) of .038kg/m³. See table for amount of charge.

Do not use means to accelerate the defrosting process or to clean, other than those recommended by the manufacturer.

The appliance shall be stored in a room without continuously operating ignition sources (for example: open flames, an operating gas appliance or an operating electrical heater).

Do not pierce or burn.

Be aware that refrigerant may not contain an odor.

WARNING

- Do not use means to accelerate the defrosting process or to clean, other than those recommended by the manufacturer.
- The appliance shall be stored in a room without continuously operating ignition sources
For example: open flames, an operating gas appliance or an operating electric heater.
- Do not pierce or burn.
- Be aware that refrigerants may not contain an odor.

MISE EN GARDE

- Ne pas utiliser de moyens autres que ceux recommandés par le fabricant pour accélérer le processus de dégivrage ou pour nettoyer l'appareil.
- L'appareil doit être entreposé dans un local ne contenant pas de sources d'inflammation permanentes (flammes nues, appareil à gaz ou dispositif de chauffage électrique en fonctionnement, par exemple).
- Ne pas percer ou brûler.
- Attention, les fluides frigorigènes peuvent ne pas dégager d'odeur.

3. Qualification: All refrigeration and electrical maintenance, service, and repair must be performed by a Certified Technician that is trained in the required flammable refrigerants safety procedures. Technicians must read the entire section "REFRIGERATION WARNINGS SECTION" of this manual.

Including but not limited to the following:

- a) breaking into the refrigerating circuit.
- b) opening of sealed components.
- c) opening of ventilated enclosures.

4. Checks to Area: Prior to beginning work on systems containing FLAMMABLE REFRIGERANTS, safety checks are necessary to ensure that the risk of ignition is minimized prior to conducting work on the system.

- Capacitors are discharged: this shall be done in a safe manner to avoid possibility of sparking.
- No live electrical components and wiring are exposed while charging, recovering or purging the system.
- Continuity of earth bonding.
- Work shall be undertaken under a controlled procedure to minimize the risk of a flammable gas or vapor being present while the work is being performed.
- All maintenance staff and others working in the local area shall be instructed on the nature of the work being carried out. Work in confined spaces shall be avoided.
- The area shall be checked with an appropriate refrigerant detector prior to and during work, to ensure the technician is aware of potentially toxic or flammable atmospheres.

Ensure that the leak detection equipment being used is suitable for use with all applicable refrigerants, i.e., non-sparking, adequately sealed, or intrinsically safe.

-If any hot work is to be conducted on the refrigerating equipment or any associated parts, appropriate fire extinguishing equipment shall be available on hand. A dry chemical or CO2 fire extinguisher should be adjacent to the charging area.

-No person carrying out work in relation to a REFRIGERATING SYSTEM which involves exposing any pipe work shall use any sources of ignition in such a manner that it may lead to the risk of fire or explosion. All possible ignition sources, including cigarette smoking, should be kept sufficiently far away from the site of installation, repairing, removing and disposal, during which refrigerant can possibly be released to the surrounding space. Prior to work taking place, the area around the equipment shall be surveyed to make sure that there are no flammable hazards or ignition risks. "No Smoking" signs shall be displayed.

-Ensure that the area is in the open or that it is adequately ventilated before breaking into the system or conducting any hot work. A degree of ventilation shall continue during the period that the work is carried out. The ventilation should safely disperse any released refrigerant and preferably expel it externally into the atmosphere.

-Where electrical components are being changed, they shall be fit for the purpose and to the correct specification to minimize the risk of possible ignition due to incorrect parts. At all times, the manufacturer's maintenance and service guidelines shall be followed. If in doubt, consult the manufacturer's technical department for assistance. The following checks shall be applied to installations using flammable refrigerants:

- a) the actual REFRIGERANT CHARGE is in accordance with the room size within which the refrigerant containing parts are installed.
- b) The ventilation machinery and outlets are operating adequately and are not obstructed.
- c) Markings of the equipment continue to be visible and legible. Markings and signs that are illegible shall be corrected.
- d) Refrigerating pipes or components are installed in a position where they are unlikely to be exposed to any substance which may corrode refrigerant containing

-Repair and maintenance to electrical components shall include initial safety checks and component inspection procedures. If a fault exists that could compromise safety, then no electrical supply shall be connected to the circuit until it is satisfactorily dealt with. If the fault cannot be corrected immediately but it is necessary to continue operation, an adequate temporary solution should be used. This shall be reported to the owner of the Initial safety checks shall include:

5. Repairs to sealed components

-During repairs to sealed components, all electrical supplies shall be disconnected from the equipment being worked upon prior to any removal of sealed covers, etc. If it is necessary to have an electrical supply to equipment during servicing, then a permanently operating form of leak detection shall be located at the most critical point to warn of a potentially hazardous situation.

-Particular attention shall be paid to the following to ensure that by working on electrical components, the casing is not altered in such a way that the level of protection is affected. This shall include damage to cables, excessive number of connections, terminals not made to original specification, damage to seals, incorrect fitting of glands, etc. Ensure that the apparatus is mounted securely.

Ensure that seals or sealing materials have not degraded to the point that they no longer serve the purpose of preventing the egress of flammable atmospheres. Replacement parts shall be in accordance with the manufacturer's specifications.

-Do not apply any permanent inductive or capacitance loads to the circuit without ensuring that this will not exceed the permissible voltage and current permitted for the equipment in use.

NOTE The use of silicon sealants can inhibit the effectiveness of some types of leak detection equipment. Intrinsically safe components do not have to be isolated prior to working on them.

8. Detection of flammable refrigerants: Under no circumstances shall potential ignition sources be used in the searching for or detection of refrigerant leaks. A halide torch (or any other detector using a naked flame) shall not be used.

The following leak detection methods are deemed acceptable for all refrigerant systems:

-Electronic leak detectors may be used to detect refrigerant leaks but, in the case of FLAMMABLE REFRIGERANTS, the sensitivity might not be adequate or might need recalibration. (Detection equipment shall be calibrated in a refrigerant-free area.) Ensure that the detector is not a potential source of ignition and is suitable for the refrigerant used. Leak detection equipment shall be set at a percentage of the LFL of the refrigerant and shall be calibrated to the refrigerant employed, and the appropriate percentage of gas (25 % maximum) is confirmed.

-Leak detection fluids are also suitable for use with most refrigerants but the use of detergents containing chlorine shall be avoided as the chlorine can react with the refrigerant and corrode the copper pipework.

NOTE Examples of leak detection fluids are

- bubble method,
- fluorescent method agents.

If a leak is suspected, all naked flames shall be removed/extinguished.

If a leakage of refrigerant is found which requires brazing, all the refrigerants shall be recovered from the system, or isolated (by means of shut off valves) in a part of the system remote from the leak.

9. Removal and Evacuation: When breaking into the refrigerant circuit to make repairs-or for any other purpose-conventional procedures shall be used. However, for flammable refrigerants it is important that the best practice be followed, since flammability is a consideration. The following procedure shall be adhered to:

- a. Safely remove refrigerant following local and national regulations.
- b. Purge the circuit with inert gas.
- c. Evacuate (optional for A2L).
- d. Purge with inert gas (optional for A2L).
- e. Open the circuit by cutting or brazing.

The refrigerant change shall be recovered into the correct recovery cylinders if venting is not allowed by local and national codes. For appliances containing flammable refrigerants, the system shall be purged with oxygen-free nitrogen to render the appliance safe for flammable refrigerants. This process might need to be repeated several times. Compressed air or oxygen shall not be used for purging refrigerant systems. For appliances containing flammable refrigerants, refrigerant purging shall be achieved by breaking the vacuum in the system with oxygen-free nitrogen and continuing to fill until the working pressure is achieved, then venting to atmosphere, and finally pulling down to a vacuum (optional for A2L). This process shall be repeated until no refrigerant is within the system (optional for A2L). When the final oxygen-free nitrogen change is used, the system shall be vented down to atmospheric pressure to enable work to take place. Ensure that the outlet for the vacuum pump is not close to any potential ignition sources and that ventilation is available.

10. Charging procedures: In addition to conventional charging procedures, the following requirements shall be followed.

- a. Ensure that contamination of different refrigerants does not occur when using charging equipment. Hoses or lines shall be as short as possible to minimize the amount of refrigerant contained in them.
- b. Cylinders should be kept in an appropriate position according to the instructions.
- c. Ensure that the REFRIGERATING SYSTEM is earthed prior to charging the system with refrigerant.

- d. Label the system when charging is complete (if not already).
- e. Extreme care shall be taken not to overfill the REFRIGERATING SYSTEM.

11. Decommissioning: Before carrying out this procedure, it is essential that the technician is completely familiar with the equipment and all its details. It is recommended good practice that all refrigerants are recovered safely. Prior to the task being carried out, an oil and refrigerant sample shall be taken in case analysis is required prior to re-use of recovered refrigerant. It is essential that electrical power is available before the task commences.

- a. Become familiar with the equipment and its operation.
- b. Isolate the system electrically.
- c. Before attempting the procedure, ensure that:
 - i. Mechanical handling equipment is available, if required, for handling refrigerant cylinders.
 - ii. All personal protective equipment is available and is being used correctly.
 - iii. The recovery process is to be supervised at all times by a competent person.
 - iv. Recovery equipment and cylinders conform to the appropriate standards.
- d. Pump down the refrigerant system, if possible.
- e. If a vacuum is not possible, make a manifold so that refrigerant can be removed from various parts of the system.
- f. Make sure that the cylinder is situated on the scales before recovery takes place.
- g. Start the recovery machine and operate in accordance with instructions.
- h. Do not overfill cylinders (no more than 80% volume liquid charge).
- i. Do not exceed the maximum working pressure of the cylinder, even temporarily.
- j. When the cylinders have been filled correctly and the process completed, make sure that the cylinders and the equipment are removed from the site properly and all isolation valves on the equipment are closed off.
- k. Recovered refrigerant shall not be charged into another refrigerating system unless it has been cleaned and checked.

12. Labeling: Equipment shall be labeled stating that it has been de-commissioned and emptied of refrigerant. The label shall be dated and signed. For appliances containing flammable refrigerants, ensure that there are labels on the equipment stating the equipment contains flammable refrigerant.

13. Recovery: When removing the refrigerant from a system, either for servicing or decommissioning, it is recommended good practice that all refrigerants are removed safely.

When transferring refrigerant into cylinders, ensure that only appropriate refrigerant recovery cylinders are employed. Ensure that the correct number of cylinders for holding the total system charge is available. All cylinders to be used are designated for the recovered refrigerant and labeled for that refrigerant (i.e., special cylinders for the recovery of refrigerant). Cylinders shall be complete with pressure-relief valve and associated shut-off valve in good working order. Empty recovery cylinders are evacuated and, if possible, cooled before recovery occurs.

The recovery equipment shall be in good working order with a set of instructions concerning the equipment that is at hand and shall be suitable for the recovery of all appropriate refrigerants including, when applicable, FLAMMABLE REFRIGERANTS. In addition, a set of calibrated weighing scales shall be available and in good working order. Hoses shall be complete with leak-free disconnect coupling and in good condition. Before using the recovery machine, check that it is in satisfactory working order, has been properly maintained and that any associated electrical components are sealed to prevent ignition in the event of refrigerant release. Consult manufacturer if in doubt.

The recovered refrigerant shall be returned to the refrigerant supplier in the correct recovery cylinder, and the relevant waste transfer note arranged. Do not mix refrigerants in recovery units and especially not in cylinders.

If compressors or compressor oils are to be removed, ensure that they have been evacuated to an acceptable level to make certain that FLAMMABLE REFRIGERANT does not remain within the lubricant. The evacuation process shall be carried out prior to returning the compressor to the suppliers. Only electric heating to the compressor body shall be employed to accelerate this process. When oil is drained from a system, it shall be carried out safely.

PRE-INSTALLATION PROCEDURES

Inspection for Shipping Damage

You are responsible for filing all freight claims with the delivering truck line. Inspect all cartons and crates for damage as soon as they arrive. If damage is noted to shipping crates, cartons, or if a shortage is found, note this on the bill of lading (all copies) prior to signing.

If damage is discovered when the case is uncrated, immediately call the delivering truck line and follow up the call with a written report indicating concealed damage to your shipment. Ask for an immediate inspection of your concealed damage item. Crating material must be retained to show the inspector from the truck line.

GENERAL ELECTRICAL & GROUNDING

IMPORTANT: Read this Section of this manual located on page 5. “REFRIGERATION WARNING & INSTALLATION-REPAIR-DECOMMISSIONING” All refrigeration and electrical work must be performed by certified technicians.

 **DANGER: Improper or faulty hookup of electrical components in the display case can result in severe injury or death.**

- All models are supplied with a power cord that is properly sized to the amperage requirements of the case. See the electrical data plate located on the rear left interior of the case for the proper circuit size for each case.
- The cord is factory installed protruding from the bottom rear corner of the case (see the “Cord Options” section of this manual that pertains to your model case for alternate location.). If factory installed cord must be relocated for desired application the electrical work must be performed by a licensed electrician.
- A separate circuit for each display case is recommended to prevent other appliances on the same circuit from overloading the circuit and causing malfunction.
- All electrical wiring hookups must be done in accordance with all applicable local, regional, or national electrical standards

INSTALLATION INSTRUCTIONS

IMPORTANT: Read this Section of this manual located on page 5. “REFRIGERATION WARNING & INSTALLATION-REPAIR-DECOMMISSIONING” All refrigeration and electrical work must be performed by certified technicians.

The installation of the appliance and the refrigerant must only be performed by Federals approved Service or suitably qualified person.

Appliance to be installed in accordance with safety standards ANSI/ASHREA 15. The appliance shall not be installed in public corridors or lobbies.

This case is designed for a class 2 environment.

<u>Test room climate class</u>	<u>Dry bulb temperature [°F]</u>	<u>Relative Humidity [%]</u>	<u>Dew point [°F]</u>	<u>Water vapour mass in dry air [lbm water/lbm air]</u>	<u>Required Test Lab Temperature [°F]</u>
2.0	71.6	65	59.36	0.0108	89.6

NSF TYPE 2 Temperature cannot exceed 75 deg F and 55% humidity.

General Display Case Location

The case should be located where it is not subjected to the direct rays of the sun, heating ducts, grills, radiator, or ceiling fans, nor should it be located near open doors or main door entrances. Also, avoid locations where there are excessive air movement or air disturbances. Allow at least 6" of clearance from end of case to any walls or partitions.

Removing Case From Shipping Skid and General Installation



CAUTION: Do not push against the top glass, front glass, end glass, doors or door frames when removing the case from the skid or moving the case. Case damage or glass breakage could result.

1. Remove crate top and sides and note missing or damaged items as explained in the pre-installation procedures outlined above.
2. Move the case as near as possible to the final location and before removing it from the shipping skid.
3. Remove the (4) brackets that secure the case to the shipping skid.
4. Prepare cabinet according to instructions in this section that pertain to your model.
5. Lift the case off of skid and into required position. Only lift the case from the frame channels located on each end of the case
6. Fasten each case to cabinet with the (4) #12 screws supplied.
7. Route electrical cord according to instructions in this section that pertain to your model.
Case must be sealed to the counter using a NSF listed sealant.
8. Install end panels.

Cleaning

For initial setup, clean the case as outlined in the "Weekly Cleaning" section of this manual.

Dry CD Model Installation

Cabinet Preparation

The CD models require (2) 1/2" dia. case fastening holes to be drilled through the counter top surface to attach case to counter. Use the diagram below for hole placement location.

IMPORTANT: When placing cases in a line up the number of end panels used will be different. The cut out and hole placement dimension will need to be adjusted for each particular line up circumstance. See LINE UPS INTALLATION section of this manual.

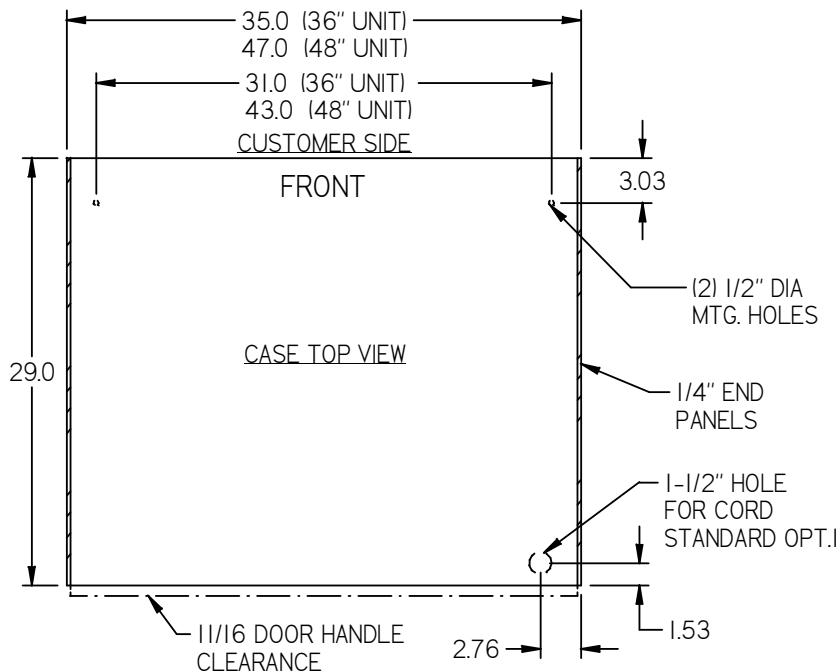

CORD OPTIONS

CORD OPTION 1: The electrical cord is shipped from the factory protruding from the bottom rear corner of the cases base. A 1-1/2" dia. hole must be drilled through the counter for the power cord clearance. See diagram below for hole placement location.

CORD OPTION 2: An additional electrical cord connection hole is provided in the rear control panel next to the case's controls. A 1-1/2" dia hole through the counter is not required for this option. NOTE: Only a licensed electrician must perform the electrical work required to move the cord to this optional position.



DANGER: Electric shock hazard. Do not operate unit with panels removed.

1. Remove the (8) screws holding the rear frame panel located under the door track and also remove the 7/8" hole plug located next to the controls in the control panel.
2. Disconnect the power cord connections and move the cord and cord strain relief from the bottom hole in the frame channel to the hole in the control panel and reconnect power cord. Plug bottom hole in frame channel with the 7/8" hole plug removed from the control.
3. Reinstall the rear frame panel.

Refrigerated CRR Self Contained Models

Cabinet Preparation

The CRR Self Contained models have a large condenser compartment hanging from the rear of the unit that contains the condenser/condensate evaporator unit. This compartment hangs off the rear edge of the counter. The rear of the counter must be open to allow space for this compartment. The countertop top should be flush with countertop back and the first top 8" of cabinet back must be flat with no doors.



DANGER: Case must be fastened to counter and counter must be fastened to floor.

IMPORTANT: The condenser air inlet and discharge louvers are located in the rear of the case. Do not block these louvers and do not locate them near a source of heat. Clearance of 8" minimum must be maintained for condenser air exchange.

(2) 1/2" dia. case fastening holes will need to be drilled through the counter top surface to attach case to counter with 1/4" X 2" screws provided. Use the diagram below for hole placement location.

IMPORTANT: When placing cases in a line up the number of end panels used will be different. The cut out and hole placement dimension will need to be adjusted for each particular line up circumstance. See LINE UPS INTALLATION section of this manual.

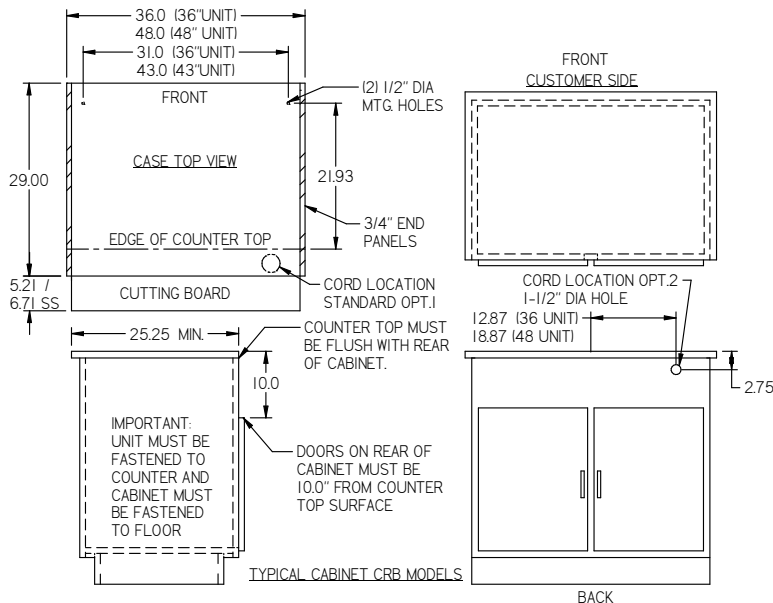

CORD OPTIONS

CORD OPTION 1: The electrical cord is shipped from the factory protruding from the A 2-3/4" hole located in the bottom rear corner of the condensing compartment and does not require a hole to be drilled into the cabinet. (You may need to reach up into 2-3/4" hole to retrieve cord.)

CORD OPTION 2: The power cord can also be allowed to drop into counter interior space. This option does not require any rewiring of the case, but does require a hole to be drilled into the back of cabinet.

1. Before placing the case onto the counter remove the (6) screws holding the condenser cover and remove the condenser cover.
2. There is a 2-3/4" hole in the lower corner of the compartment and a 2-3/4" hole plug in the compartment back. Remove the 2-3/4" plug from the back hole and place it into the bottom hole.
3. Install and fasten the case onto the counter.
4. Drill a 1-1/2" hole through the counter back in the location of the 2-3/4" hole for power cord to be dropped into cabinet compartment.
5. Reinstall the condenser cover and the (6) screws.

OPTION 3: An electrical cord connection hole is provided in the rear control panel next to the controls. A 1-1/2" dia hole through the counter is not required for this option. NOTE: Only a licensed electrician must perform the electrical work required to move the cord to this optional position.



DANGER: Electric shock hazard. Do not operate unit with panels removed.

1. Before or after the case has been installed onto the counter remove the (6) screws holding the condenser cover and remove the condenser cover.
2. Remove the (4) screws holding the rear frame panel located under the door track. Loosen the (4) screws holding the cutting board under each end of the cutting board. Tilt and lift the rear panel out from behind the cutting board.
3. Remove the 7/8" hole plug located next to the controls in the control panel. Disconnect power cord connections and move cord and cord strain relief from bottom hole in frame channel to the 7/8" hole in the control panel. Reconnect power cord and plug bottom in frame channel with the 7/8" hole plug removed from the control panel.
4. Reinstall the condenser cover and the rear frame panel and retighten the cutting board mounting screws.

Refrigerated CRB Self Contained Models (SEE 91-18700, E2964)

Cabinet Preparation

The CRB Self Contained models have a large condenser compartment hanging from the bottom of case that contains the condenser/condensate evaporator unit. This compartment hangs inside the cabinet compartment. The interior of the cabinet must be open to allow space for this compartment and air movement. The countertop must be cut to allow the case's base and condenser compartment to drop into the cabinet interior. Use the diagram below for cutout dimensions.

The condenser air inlet and discharge louvers are located on each side of the case condenser compartment. The cabinet interior must have a divider that isolates intake and the exhaust sides of the condenser air. The provided gasket must be attached to case in divider location to insure a seal between the air intake and air discharge sides of condenser compartment. The Louvers provided must also be installed on each side of these compartments for required condenser outside cabinet air exchange. The louvers can be installed in either the front or the rear of the cabinet, as long there is a min. of 8" air space (drawing shows louvers in rear for reference only). The cabinet compartment must not be used for storage or air restriction may occur.

(2) 1/2" dia. case fastening holes will need to be drilled through the counter top surface to attach case to counter with 1/4" X 2" screws provided. Use the diagram below for hole placement location.

IMPORTANT: Federal Industries reserves the right to deny warranty if the cabinet is not divided internally and the cabinet louvers not installed properly, blocked or located near a source of heat.

IMPORTANT: When placing cases in a line up the number of end panels used will be different. The cut out and hole placement dimension will need to be adjusted for each particular line up circumstance. See LINE UP INTALLATION section of this manual.

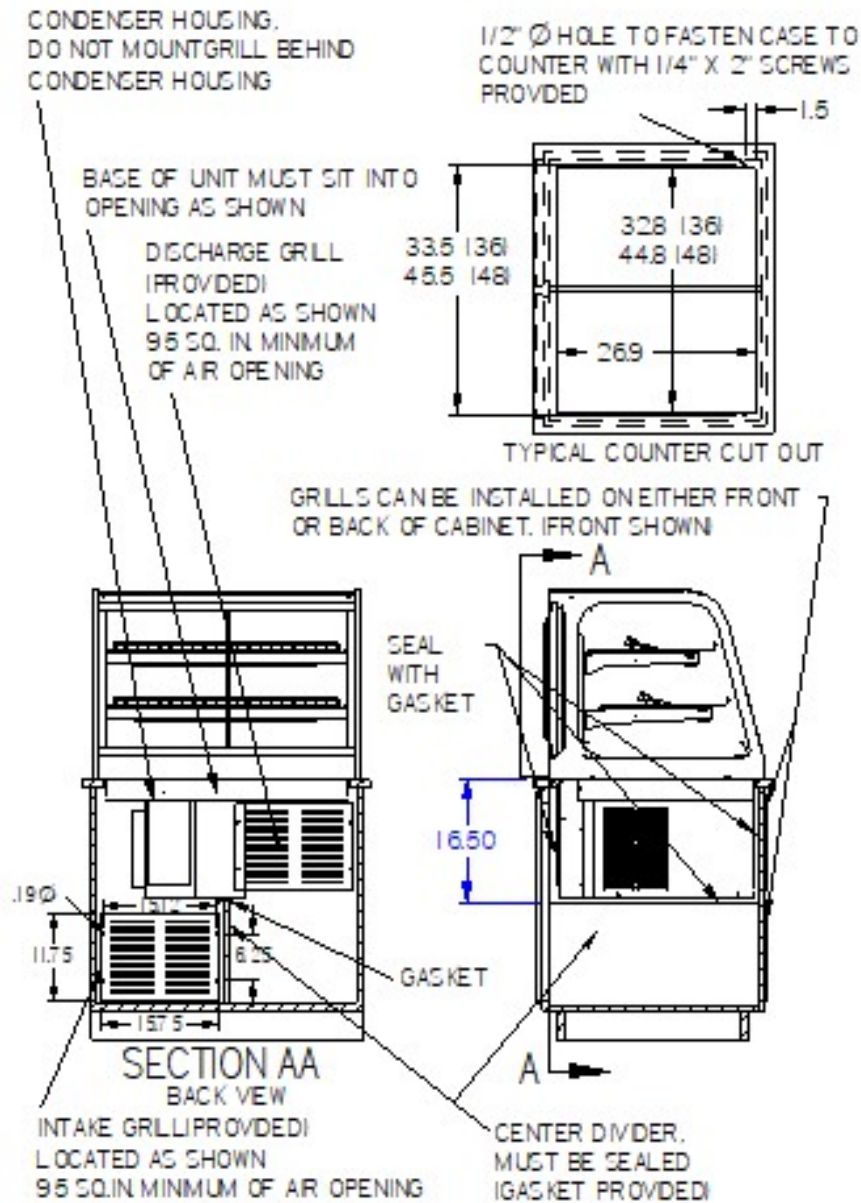

CORD OPTION 1: The electrical cord is shipped from the factory protruding from the bottom rear corner of the base and will fall through the required cut in counter. After the case has been installed and fastened onto the counter, plug cord into a proper power source.

CORD OPTION 2: An additional electrical cord connection hole is provided in the rear control panel next to the case's controls. A 1-1/2" dia hole through the counter is not required for this option. NOTE: Only a licensed electrician must perform the electrical work required to move the cord to this optional position.



DANGER: Electric shock hazard. Do not operate unit with panels removed.

1. Remove the (8) screws holding the rear frame panel located under the door track and also remove the 7/8" hole plug located next to the controls in the control panel.
2. Disconnect the power cord connections and move the cord and cord strain relief from the bottom hole in the frame channel to the hole in the control panel and reconnect power cord. Plug bottom hole in frame channel with the 7/8" hole plug removed from the control.
3. Reinstall the rear frame panel.

Refrigerated CRR Remote Models:

Cabinet Preparation

The CRR remote sets directly on top of the counter and refrigeration and evaporator condensate drain lines must run through the counter top surface. The evaporator condensate drain must run to a floor drain and refrigeration lines to a remote condenser unit

(2) 1/2" dia. case fastening holes will need to be drilled through the counter top surface to attach case to counter with 1/4" X 2" screws provided. A 2-1/2" dia. hole will also need to be drilled through counter top for refrigeration lines and evaporator condensate tube connections. Use the diagram below for hole placement location.

IMPORTANT: When placing cases in a line up the number of end panels used will be different. The cut out and hole placement dimension will need to be adjusted for each particular line up circumstance. See LINE UP INTALLATION section of this manual.

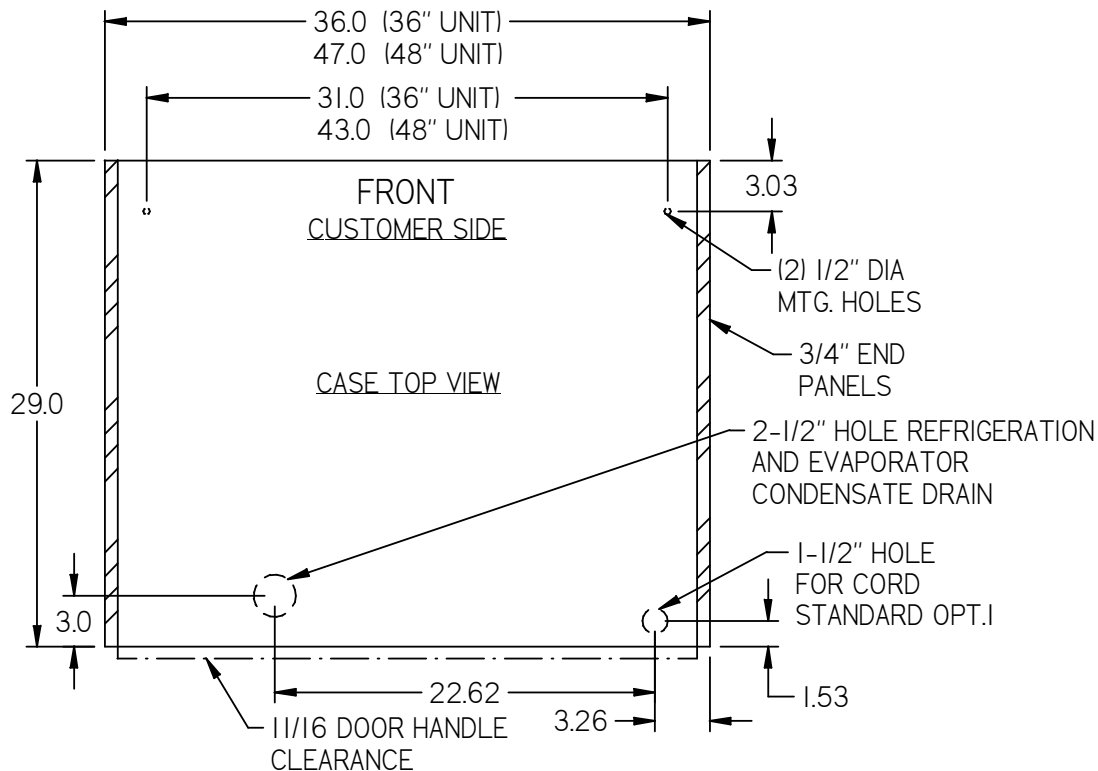

CORD OPTIONS

CORD OPTION 1: The electrical cord is shipped from the factory protruding from the bottom rear corner of the cases base. A 1-1/2" dia. hole must be drilled through the counter for the power cord clearance. See diagram below for hole placement location.

CORD OPTION 2: An additional electrical cord connection hole is provided in the rear control panel next to the case's controls. A 1-1/2" dia hole through the counter is not required for this option. NOTE: Only a licensed electrician must perform the electrical work required to move the cord to this optional position.



DANGER: Electric shock hazard. Do not operate unit with panels removed.

1. Remove the (8) screws holding the rear frame panel located under the door track and also remove the 7/8" hole plug located next to the controls in the control panel.
2. Disconnect the power cord connections and move the cord and cord strain relief from the bottom hole in the frame channel to the hole in the control panel and reconnect power cord. Plug bottom hole in frame channel with the 7/8" hole plug removed from the control.
3. Reinstall the rear frame panel.

Connect remote refrigeration lines and condensate evaporator drain.

1. Remove the rear refrigeration line cover by removing the (4) screws on each end of base and the (3) screws from under the rear frame channel.
2. Connect remote refrigeration lines through the 2-1/2" hole in counter as described in the Remote Connection section in this manual.
3. Connect the provided condensate evaporator drain hose through the 2-1/2" hole in counter by pushing it onto the drain fitting and secure it with provided hose clamp. Run the hose to a floor drain or a remote condensate evaporator pan.

Refrigerated CRB Remote Models:

Cabinet Preparation

The CRB Remote models have a large condensate evaporator compartment hanging from the bottom of case that contains the condensate evaporator pan. This compartment hangs inside the cabinet compartment. The interior of the cabinet must be open to allow space for this compartment. The countertop must be cut to allow the case's base and condenser compartment to drop into the cabinet interior. Use the diagram below for cutout dimensions.

IMPORTANT: When placing cases in a line up the number of end panels used will be different. The cut out and hole placement dimension will need to be adjusted for each particular line up circumstance. See LINE UP INTALLATION section of this manual.

The condensate air louvers are located on each side of the condensate evaporator compartment. Do not block these louvers. The louver panel provided with case must be installed in the cabinet to allow condensate moisture to vent. The louver can be placed on any side of cabinet, but must be as near to the top as possible. A 6" minimum clearance must be maintained from cabinet louver.

Also (2) 1/2" dia. case fastening holes will need to be drilled through the counter top surface to attach case to counter with 1/4" X 2" screws provided. Use the diagram below for hole placement location.

IMPORTANT: When placing cases in a line up the number of end panels used will be different. The cut out and hole placement dimension will need to be adjusted for each particular line up circumstance. See LINE UP INTALLATION section of this manual

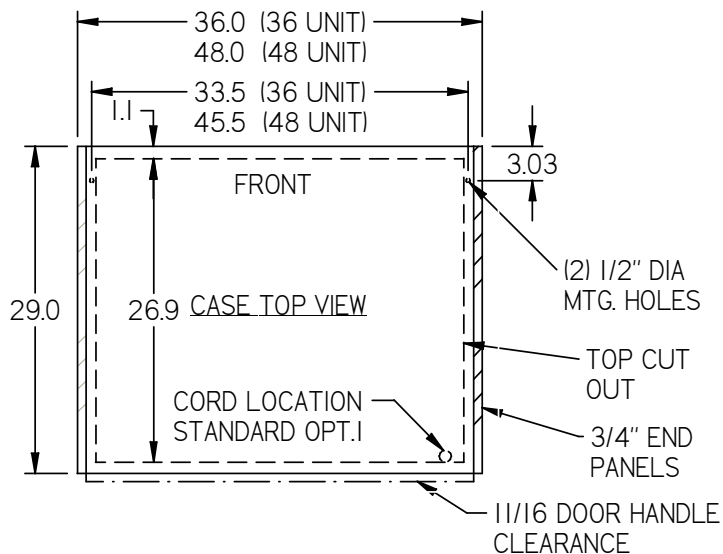

CORD OPTION

OPTION 1: The electrical cord is shipped from the factory protruding from the bottom rear corner of the base and will fall through the required cut in counter. After the case has been installed and fastened onto the counter, plug cord into a proper power source.

CORD OPTION 2: An additional electrical cord connection hole is provided in the rear control panel next to the case's controls. A 1-1/2" dia hole through the counter is not required for this option. NOTE: Only a licensed electrician must perform the electrical work required to move the cord to this optional position.



DANGER: Electric shock hazard. Do not operate unit with panels removed.

1. Remove the (8) screws holding the rear frame panel located under the door track and also remove the 7/8" hole plug located next to the controls in the control panel.
2. Disconnect the power cord connections and move the cord and cord strain relief from the bottom hole in the frame channel to the hole in the control panel and reconnect power cord. Plug bottom hole in frame channel with the 7/8" hole plug removed from the control.
3. Reinstall the rear frame panel.

Connect remote refrigeration lines.

1. Remove the cover by removing the (4) screws on the bottom of case inside the cabinet compartment.
2. Connect remote refrigeration as described in the Remote Connection section in this manual. A 2-3/4 hole through the condensate evaporator compartment is provided.
3. Make sure that the drain line has not been dislodged during shipment and that the drain trap is located properly over the water reservoir of the condensate evaporator pan.
4. Reinstall evaporator condensate cover.

Condensing Unit Air Flow.

The remote condensing unit must be installed to allow separation of coil intake air and coil discharge air. The coil discharge air must not be allowed to recirculate back into the coil intake. Condensing unit coil intake air temperature should be as cool as possible and should not exceed 80 Degrees F.

Refrigeration Installation (Refrigerated units)

Self Contained Models

The self-contained models are shipped from the factory with a completely operational R290A refrigeration system and require no modifications or adjustments upon installation.

Remote Models

The remote models are designed to use 513A refrigerant and shipped from the factory with the evaporator coil, expansion valve, refrigerant solenoid valve and thermostat. The thermostat senses interior case temperatures and opens and closes the refrigerant solenoid valve as needed to maintain proper case temperatures. The condensing unit is optionally supplied from the factory for remote location installation.

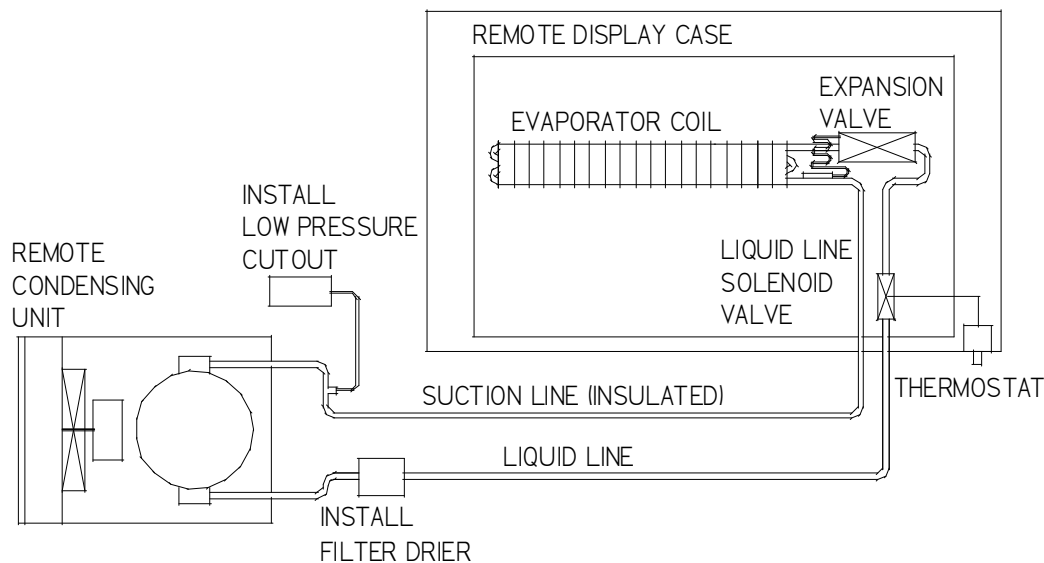

1. Mount condensing unit indoors as close to the remote display case as practical. The refrigeration line should be as short as possible and must not exceed 30 feet.

2. All refrigeration and/or electrical materials between the condensing unit and display case are to be supplied by installing contractor.
3. Route properly sized and designed refrigeration lines from the condensing unit to the cabinet. Horizontal suction lines should be pitched downward towards the condensing unit at least 1/2" per 10' run to aid the oil drainage. A "P" trap must be installed in the suction line at the foot of every riser to insure oil return. Dry nitrogen should be used to flow through tubing while brazing refrigeration lines.
4. Suction line must be insulated the entire length with Armaflex (or equivalent). Do not run liquid line inside insulation with suction line.
5. The filter drier, sightglass, and low-pressure control are not furnished with remote display case models. The recommended low pressure setting for R513A refrigerant is 32# cut in and 0# cutout.
6. Leak check condensing unit, cabinet, and all connecting tubing. Cabinet and condensing unit tubing should be checked to insure no leaks occurred during shipping or from rough handling. Make certain all refrigeration valves are opened and evacuate system to 500 microns. Charge the system with refrigerant type specified on the data plates.

Case Line Up Installation

Follow the "Case Installation" procedures in this manual for each display case that is going to be adjoined in a lined up. Additional cases must be placed directly next to the adjoining end of the first case

IMPORTANT: BEFORE CUTTING COUNTER TOP:

When placing cases in a line up the number of end panels used will be different. The cut out and hole placement dimension will need to be adjusted for each particular line up circumstance as listed below.

- REFRIGERATED TO REFRIGERATED: (1) 3/4" end panel attached to one of the cases. It does not matter which case.
- REFRIGERATED TO DRY: (1) 3/4" end panel attached to the refrigerated case.
- REFRIGERATED TO HOT: (1) 1-1/2" end panel attached to the refrigerated case.
- DRY TO HOT: (1) 1-1/2" end panel attached to the refrigerated case.

Note: The end panel screws and plastic spacers are not used on the case that does not get an end panel when being butted up to a case with an end panel. Remove them from case and discard.

Once the cases are placed together with proper end panel(s). They will need to be pushed together as close as possible keeping the front of the cases in alignment. Once adjoining case is in proper position complete all of the procedures outlined in the "Case Installation" section in this manual before installing the joining kit as outlined below.

Top Joining Bracket

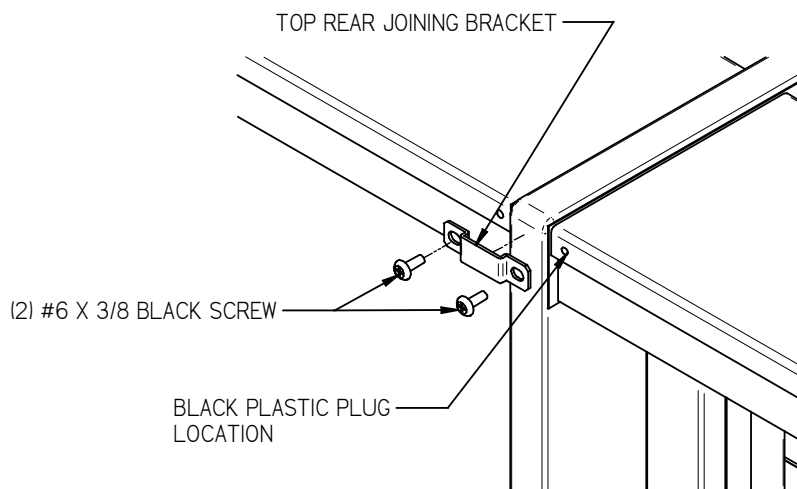

All cases joined together should have a top joining bracket installed to keep the top of the case tight together. There are different brackets included with each case to cover most joining combination needs. If no holes are provided, drill a 1/8" dia x 1/2" deep hole in location needed for bracket attachment.

1. Remove the black plug from the hole located on the upper rear corner of case.
2. Find the correct bracket shipped with case and place it over the end panel(s).
3. Hold the two cases together as much as possible to eliminate gap and fasten with screw.

Bottom Pedestal Joining

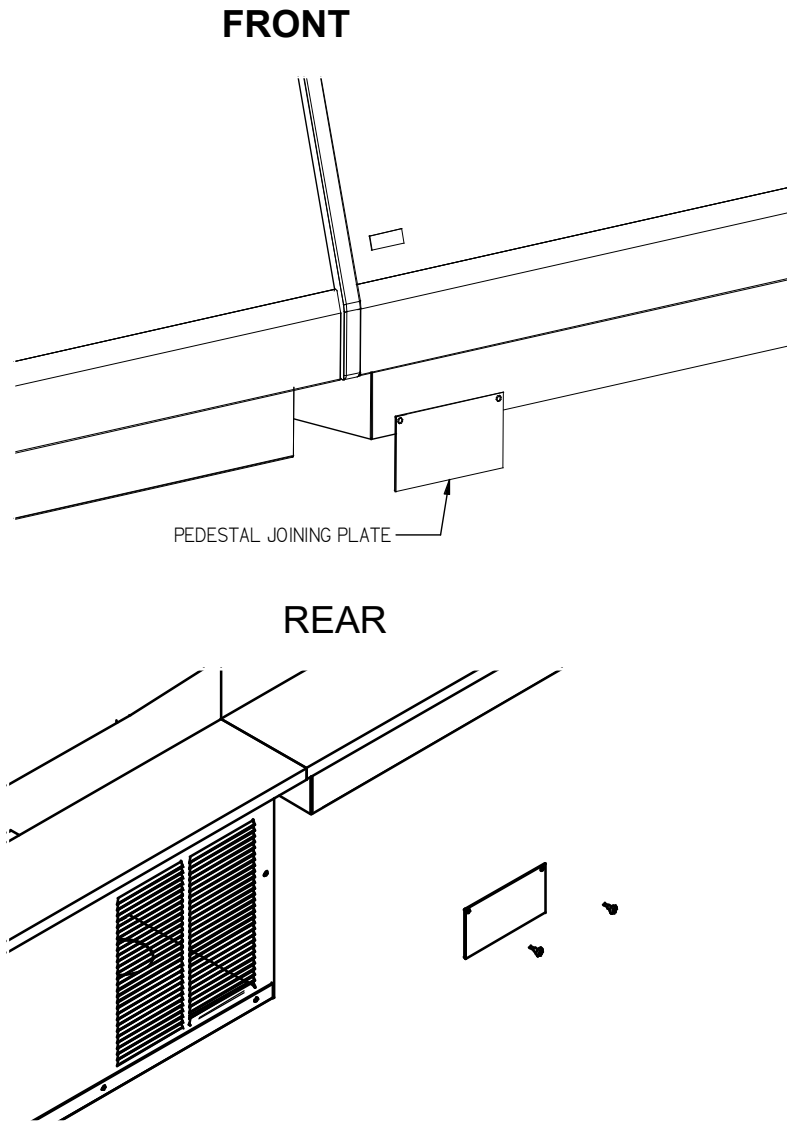

The CRR model cases and cases with optional pedestal have a 2-3/4" pedestal that sets on top the counter.

When these cases are joined there is a gap between the pedestals. Two joining plates are provided for these models.

The front plate is attached with self adhesive tape as follows:

1. Clean the front corner area on pedestal with rubbing alcohol
2. Remove adhesive backing strips from pedestal joining plate.
3. Center plate over opening and press firmly into place.

The rear plate must be attached with provided screws as follows: (Screw removal will be required to access condenser compartment so do not use adhesive backing.)

1. Center plate at top of condenser compartments directly below cutting boards.
2. Mark location of (2) screw holes in cover plate on to each condenser panel.
3. Attach cover plate with (2) self drilling screws.

END PANEL INSTALLATION INSTRUCTIONS

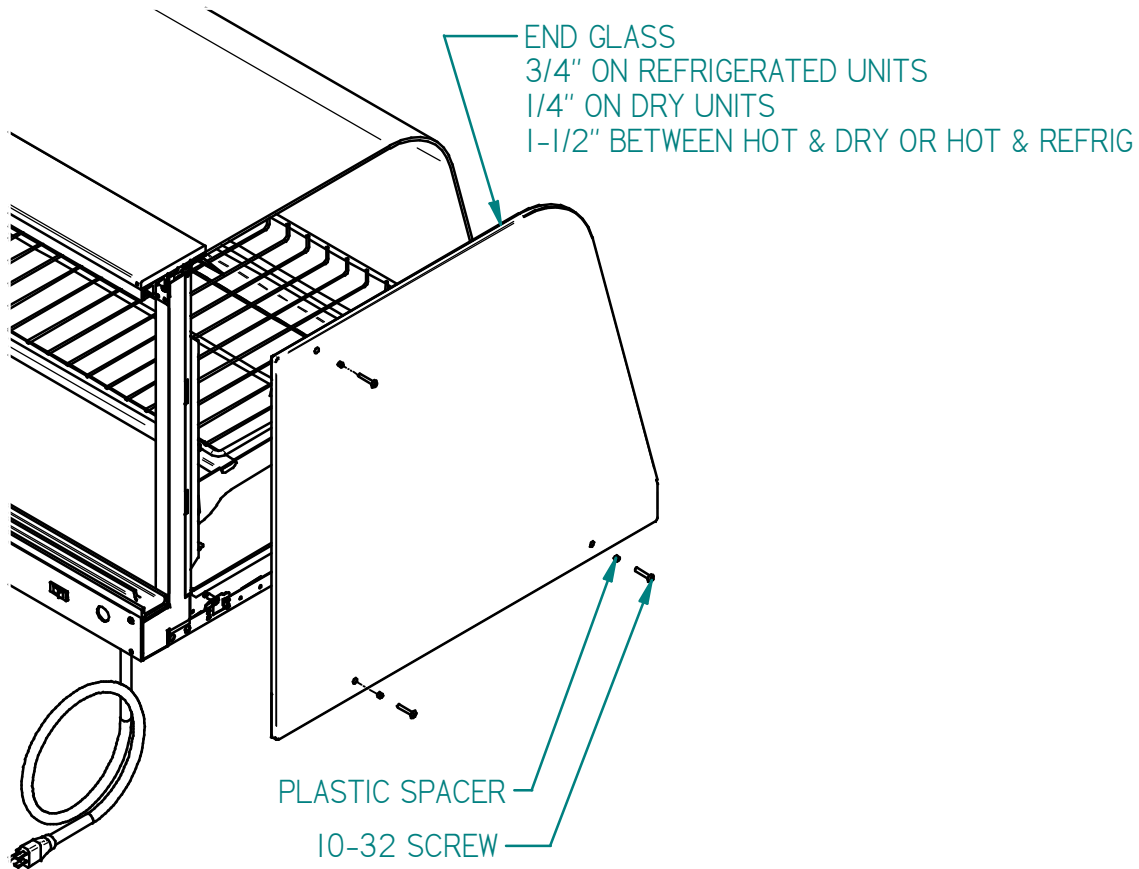

End panels are Ordinarily shipped loose from the factory and need to be installed once the case fastened to the counter. When placing cases in a line up the number of end panels and end panel type will be different for each line up circumstance. See Case Line Up Installation section of this manual.

1. Place end panel on to the side of case and align holes.
2. Place a plastic spacer on to a screw and install the screw through the hole on end panel and into the case. Do not tighten screws until all (3) screws are started and then snug screws up, but do not over tighten or glass breakage may occur.
3. Repeat for all ends that require an end panel.

SHELVING INSTALLATION & REMOVAL

Shelf Brackets and Supports

1. Turn the light switch to the off position. Remove rear doors as described in the “Rear Door Removal” section of this manual to allow access to interior of case.
2. For first time installation, it may be necessary to attach the clear plastic clips to only the shelf brackets located on the side of the shelf light cord. Use the 6-32 x ¼ flat head screws supplied with unit to attach clear plastic clips to the 1/8 hole on the inside of the shelf brackets. It may also be necessary to attach the clear bumper to the outside end towards the side glass of each shelf bracket. The bumper prevents damage to the end glass. These steps may have already been performed at the factory for you. Insert a longer bottom shelf bracket in the desired shelf standard slot on one side of case (bumper side towards end glass). Follow the instruction in the illustration below. Place the additional longer bottom shelf bracket in the same slot in shelf standard on the opposite end of case. Repeat for shorter top shelf tier.

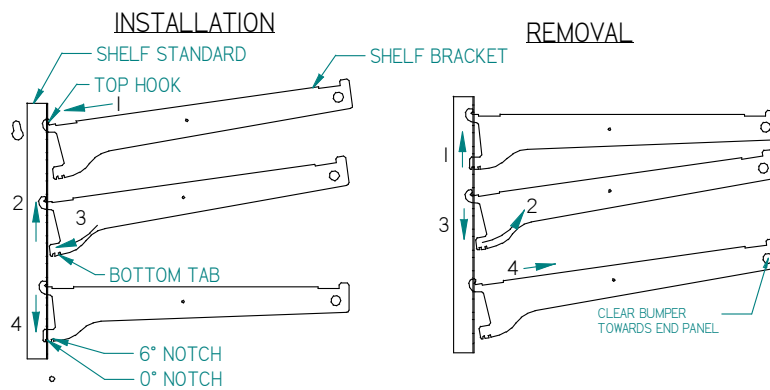

1. Place shelf bracket top hook into desired shelf standard slot.
 2. Lift shelf bracket top hook to allow shelf bracket bottom tab to clear shelf standard slot.
 3. Swing shelf bracket bottom tab into shelf standard slot.
 4. Place the desired shelf bracket notch of 0, 6, or 12 degrees onto bottom of shelf standard slot.
1. Lift shelf bracket up to allow shelf bracket notch to clear the bottom of shelf standard slot.
 2. Swing shelf bracket bottom tab out of shelf standard slot.
 3. Drop shelf bracket down to allow shelf bracket top hook to clear top of shelf standard slot.
 4. remove shelf bracket top from shelf standard slot.

3. Hang one end of shelf light housing on the front notch of a shelf bracket and then the other end of shelf light housing on the notch of the shelf bracket on the opposite end. Repeat for each additional shelf tiers. NOTE: On models without shelf lights, use a shelf support instead of a shelf light housing.
4. Push shelf light cords into clear plastic clip located on inside of shelf brackets.
5. Remove the cap from the appropriate female light sockets. If socket is not being used for a shelf light, the cap must be plugged into socket for entire light system to operate. NOTE: Grip each side of cap firmly and wiggle and pull cap straight out of socket. Do not roll cap during removal.
6. Plug in each shelf light by aligning the male pins on the appropriate shelf light cord plugs with the female light sockets and push together. NOTE: Do not roll plug during insertion.
7. Hang one end of the shelf support on to the rear notch of one shelf bracket and then on the rear notch of the shelf bracket on the opposite side. Repeat for additional shelf tiers.
8. Place supplied shelving onto shelf supports as outlined in the appropriate “Shelf Installation” section of this manual.
9. On units with sliding rear doors, re-install both rear doors by lifting top of door into top track and swinging bottom of door onto bottom track. Install door labeled “inner door” first on inner track and door labeled “outer door” second on outer track.

Shelves and shelf light quantity

It is not required that all shelves and shelf lights supplied with each case are used. The quantity of shelves and shelf lights can be tailored to your specific needs. If the supplied quantity of shelves and shelf lights are not required, cap unused female socket located in interior of the case mullion with caps supplied.

Wire Shelves Installation

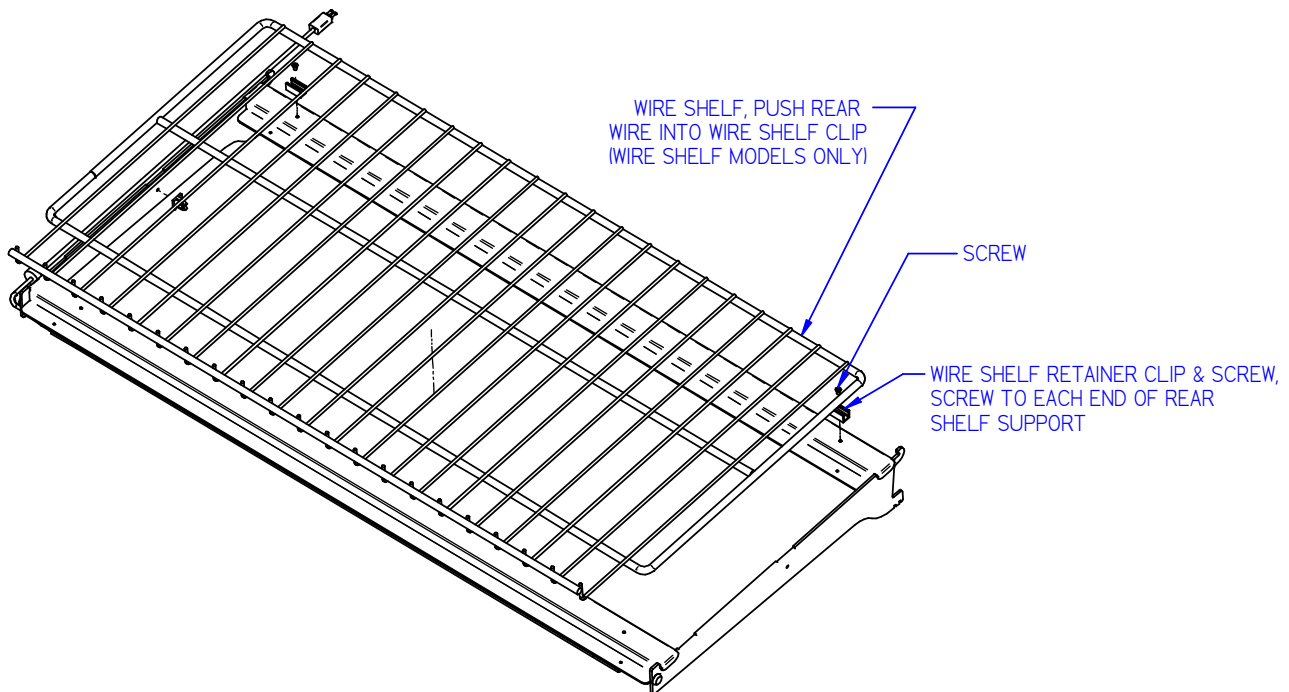

Glass Shelves Installation

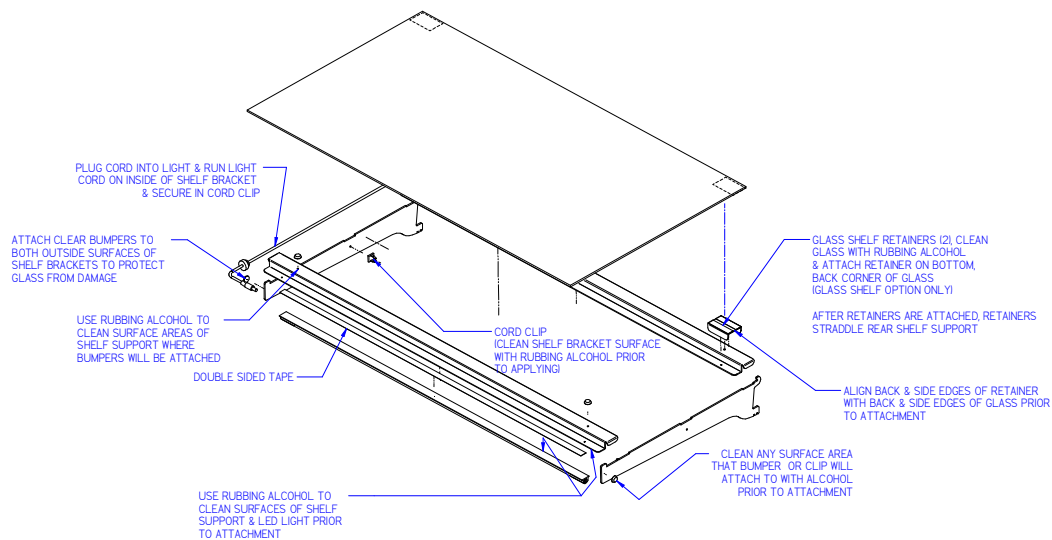

1. For first time installation attach (2) glass shelf holders to each glass shelf. Remove backing from tape located on flat side of glass shelf holder. Position the glass shelf holders in the (2) far corners of glass. Repeat for each glass shelf. Attach a clear bumper on both sides of the light housing top surface for the front of the glass to set on. This step may have already been performed at the factory for you.

NOTE: Clean area of glass where glass shelf holder is to be located with rubbing alcohol and let air dry before installing shelf glass holder.

2. With rear sliding doors removed, place front of glass shelf onto front shelf light. (On front shelf support for models without shelf lights.)

3. Let the rear of the glass shelf onto the rear shelf support so that the glass shelf holder straddles the rear shelf support. If clear plastic clips were factory-installed on top of rear shelf support, remove and discard clear plastic clips.

4. Repeat steps 2 & 3 for each tier.

Metal Shelves Installation

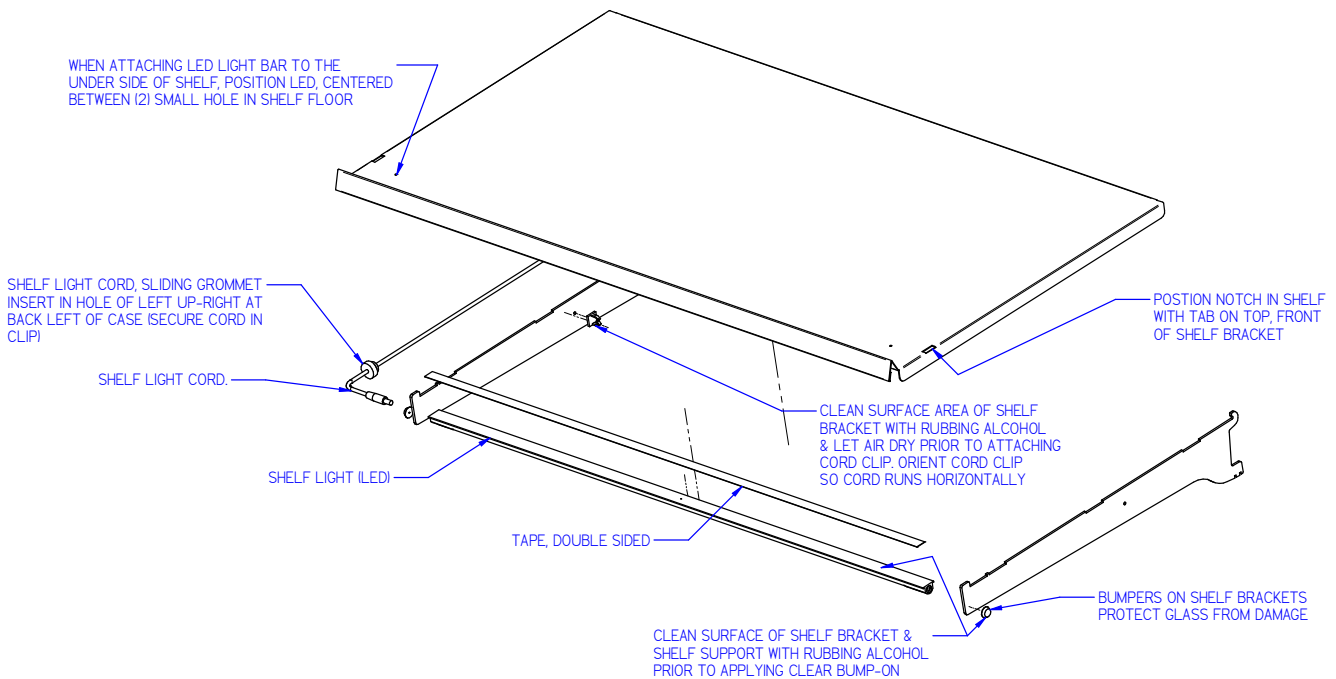

1. With rear sliding doors removed, place front of the metal shelf onto front shelf light. (On front shelf support for models without shelf lights)
2. Align slots on each side of the shelf with the tabs on the front of each shelf bracket.

DOOR REMOVAL INSTRUCTIONS

ALL SERVICE CASES & SELF SERVE DRY

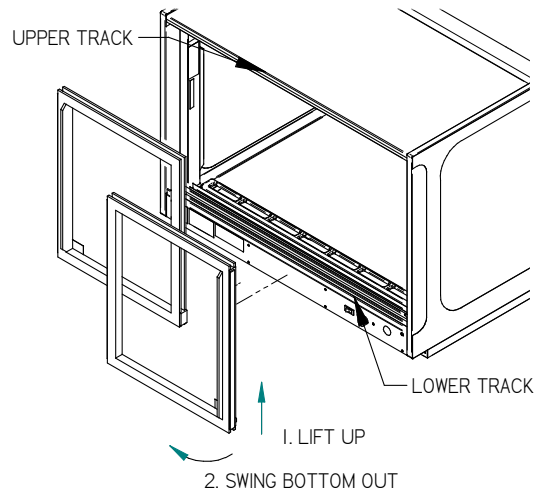

1. Start with the outer door and lift the door upward until the bottom edge of door clears the lower track and then swing the bottom of the door outward and down out of upper track.
2. After the outer door is removed repeat the procedure for the inner door.
3. Reverse this procedure for door reinstallation. The doors are not interchangeable.

SELF SERVE REFRIGERATED CASES

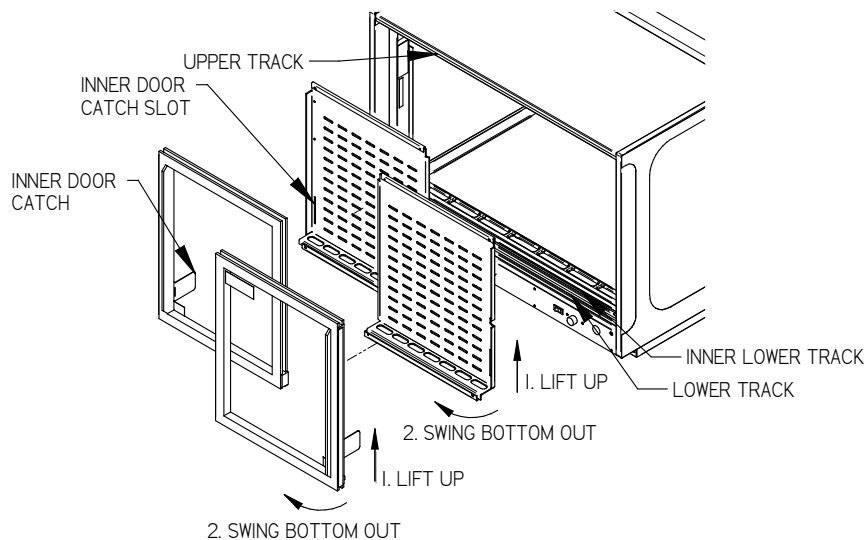

1. Start with the outer outside door and lift the door upward until the bottom edge of door clears the lower track and then swing the bottom of the door outward and down out of upper track.
2. Remove the outer inside door using the same procedure.
3. The inner door set can then be removed using the same procedure starting with the inner outside door followed by the inner inside door.
4. Reverse this procedure for door reinstallation starting with the inner inside door followed by the inner outside door. Check that the doors slide freely.
5. Replace the outside inner door and the outside outer door. Be sure to slide the inner door catch into the inner door catch slot for each door.

Note: None of the doors are not interchangeable and they must be replaced in the same location that they were removed from.

OPERATING INSTRUCTIONS

Controls (Refrigerated Units)

Light Switch

This switch controls the power to the lighting circuit. The switch rocker is red in the “on” position, black in the “off” position.

Temperature Control

This controls the refrigerated side by cycling the compressor/condensing unit. It has an “off” position and the coldest setting when the knob is set all the way in the clockwise position. Set this control at the lowest setting possible, while maintaining desired case temperature.

Controls (Non-Refrigerated Units)

Power Switch

This switch controls the power to the lighting circuit and to the optional interior fan if supplied. The switch rocker is red in the “on” position and black in the “off” position.

Shelves

Each display is furnished with shelves that are adjustable up and down and can be tilted in two angular positions. See “Shelving Installation & Removal” section of this manual for proper installation, adjustment and removal of shelving.

Rear Package Shelf Pedestal (optional)

The rear package shelf is provided with the 2-3/4” pedestal option. It is not adjustable up and down. And can be removed by loosening the retainer screws under the shelf and sliding out through keyhole slots. After completing shelving installation as outlined in “Shelving Installation and Removal” section of this manual you may begin placing product into the display case.

Placing Product into Case

- Do not exceed 100 pounds of weight per shelf. Heavy product should be distributed evenly across the entire shelving area.
- Determine desired shelving location and angle before placing product in case. Product must be removed to readjust shelf location and angle.
- Allow a minimum of 2” between the top of product and bottom of shelf.

(Refrigerated Models)

- Do not overhang the front of wire shelves with product. Product may overhang rear of shelf, but allow a minimum of 1-1/2” between product and rear door. Improper clearance in front and rear of shelf will block the refrigerated airflow and could cause product loss.
- Do not block the slots along the front or rear of the case display pan. Covering these slots will block the refrigerated airflow and could cause product loss.
- The display pan is removable for cleaning and can become dislodged in shipment. To ensure proper airflow and performance of the case, make sure that the display pan is pushed completely down into evaporation tub. Check that the pan is installed properly before placing product the display pans.
- Allow refrigerated models to run for at least two hours before placing pre-chilled product into unit. Turn temperature control to the lowest possible position that maintains required interior cabinet temperature.

-CASE SHOULD BE STOCKED WITH PRE-CHILLED PRODUCT ONLY.

ATTENTION:

- Federal refrigerated display cases are designed to operate in a maximum environment of 75 DEG. F and 55% relative humidity. Exceeding these limits could cause poor case performance and sweating of glass panels.

Solid-State Max. Run Timer

Used in all self-serve refrigerated cases only.

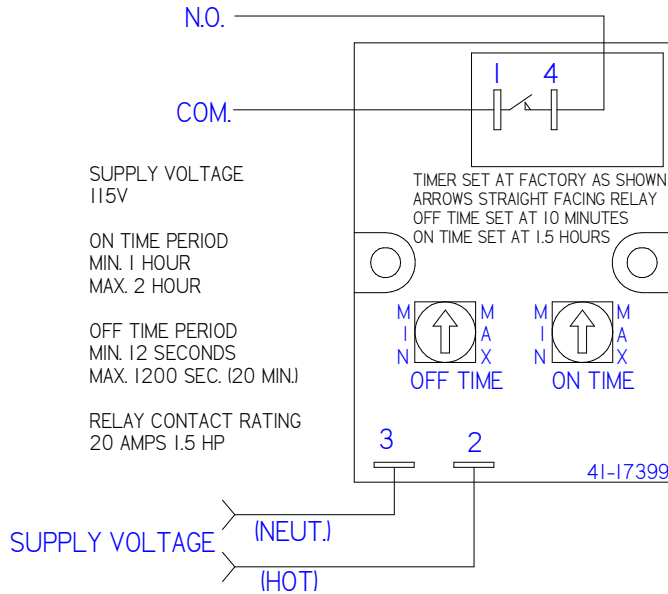

OPERATION: APPLY SUPPLY VOLTAGE - RELAY TRANSFERS (CONTACT CLOSSES) AND TIME PERIOD 1 (ON TIME) BEGINS. AFTER INITIAL DELAY, RELAY TRANSFERS AGAIN (CONTACT OPENS) FOR DURATION OF TIME PERIOD 2 (OFF TIME) THIS RECYCLING CONTINUES UNTIL SUPPLY VOLTAGE IS REMOVED

Electronic Expansion Valve (EEV)

A traditional TXV uses springs and a temperature bulb to open and close a valve port that controls the flow of refrigerant entering the evaporator coil. An electronic expansion valve (EEV) controls the refrigerant flow much more precisely, increasing the performance and efficiency of the refrigeration system. The EEV controls the flow of Refrigerant by opening and closing the valve port based on the response to signals sent to the EEV by an electronic controller. The electronic Control bases these signals by processing information provided from a temperature sensor and pressure transducer located on the discharge side of the evaporator coil.

These sensors monitor the evaporator superheat and protects the compressor from any liquid flood back under low superheat conditions.

EEV Controller Settings

The electronic expansion valve controller also allows the use of different types of refrigerants without the need to change the expansion valve.

The controller is set from the factory to run on 449A refrigerant and will not need any changes to the control unless another refrigerant is used.

Note: Check your State and Local regulations for approved refrigerants for your install location. Federal Industries is not liable for any alternate refrigerants used.

The control is located in the front of the Condo Pan.

Note: Never change any of the other setting other than the refrigerant type. It may also be necessary to change the superheat setting only when using a different refrigerant.



Indicator lights	
Red light	- critical alarm (system is NOT running)
Yellow light	- non-critical alarm (system running)
Green light	- compressor on
Green blinking	- compressor waiting on timer to start/stop

Changing Refrigerant

- Access the set point mode by pressing and holding the **ENTER** button until Ctl displays on the screen.
- Use the **▲** up or **▼** down arrows to advance through the available set points until rFG displays on the screen and press the **ENTER** button.
- Use the **▲** up or **▼** down arrows until the desired refrigeration displays on the screen and press and hold the **ENTER** button until rFG once again displays on the screen.
- Press the **BACK** to return to escape the settings menu.

Changing Superheat

- Access the set point mode by pressing and holding the **ENTER** button until Ctl displays on the screen.
- Use the **▲** up or **▼** down arrows to advance through the available set points until SSP displays on the screen and press the **ENTER** button.
- Use the **▲** up or **▼** down arrows to set the desired superheat displays on the screen and press and hold the **ENTER** button until SSP once again displays on the screen.
- Press the **BACK** to return to escape the settings menu.

MAINTENANCE

LED Light Replacement

1.1 LIGHT REPLACEMENT

1. Remove both rear doors as described in the “Door Removal” section of this manual.
2. Remove shelving from unit through rear door opening as described in the “Shelving Installation and Removal” section of this manual.
3. Unplug appropriate light cord from socket and remove shelf from unit through rear door opening.

All lights are LED Bar type. If replacement should become necessary, follow the directions below to replace LED lights.

TOP LIGHT

5. Unplug cord from light
6. Carefully pry plastic clip tab away from lip on LED light body, with a slight rotational motion, disengage the clip locking tab on each of the plastic clips. Install replacement LED by inserting lip on replacement LED body under the locking tab on plastic clip and snap into place

Re-install cord plug.

SHELF LIGHTS

7. Unplug cord from light
8. Use putty knife to pry LED light body from Shelf and or Top Light Liner. It may be useful to slide the putty knife along the length of light once putty knife is between

LED light body and component surface. (it is recommended to remove shelves from case when replacing LED lights)

9. Remove residual adhesive tape from shelf / top light liner and clean surface with alcohol
 10. Remove liner from Double Sided Tape on replacement Light
 11. Use small holes in Top Light Liner & Shelves as a locational guide for LED placement
 12. Mount light and apply pressure along the length of LED body to ensure good adhesion
- Re-install shelf and cord plug.

PERIODIC MAINTENANCE

IMPORTANT: Read this Section of this manual located on page 5.
“REFRIGERATION WARNING & INSTALLATION-REPAIR-DECOMMISSIONING”
All refrigeration and electrical work must be performed by certified technicians.

Cleaning Condenser Coil (All Refrigerated Units)

It is very important that the Condenser coil is cleaned on a monthly basis to insure proper refrigeration performance and to prevent compressor failure.



Self Contained Refrigerated Units

1. Disconnect power to the unit.
2. On CRR models remove the condenser cover located on the rear of the condenser compartment by removing the (6) condensing cover retaining screws.
3. On CRB remove both the condenser covers on each side of the condenser compartment by removing the (4) condensing cover retaining screws on each cover.
4. Carefully vacuum the front surface of condenser coil. Take care not to bend coil fins with vacuum cleaner nozzle.
5. Reinstall condenser covers and condenser cover retaining screws.

CLEANING INSTRUCTIONS

Daily Cleaning

The case should be cleaned thoroughly, as described in the weekly cleaning section, before it is used for the first time.

	NOTICE:	Avoid splashing or soaking any electrical components with water to prevent electrical damage to the case.
	NOTICE:	Shut off lights and power switches and remove all product from case. Allow sufficient time for the unit to reach room temperature before proceeding with cleaning.
	NOTICE:	Remove all product from case before proceeding with cleaning procedure.

**NOTICE:**

Acrylic end panels and top panel require special washing procedures to prevent hazing and yellowing of material. Read cleaning of end panel and top panel procedure carefully.

Note: For major spills or foreign material buildup perform the weekly cleaning instructions.

1. Clean all foreign materials from the door opening.
2. Wipe complete interior of case using a damp cloth.
3. Clean both sides of the doors and interior and exterior of the front glass using any common window cleaner. **IMPORTANT:** Do not allow glass cleaner to contact $\frac{3}{4}$ " Acrylic plastic end panels or Acrylic plastic top panel.
4. Clean the end panels and top panel. **IMPORTANT:** The $\frac{3}{4}$ " end panels and top panel are acrylic plastic and special care must be taken to prevent hazing and yellowing of material. Lightly dust (not wipe) surface with clean, soft cloth. Then the surface can be wiped carefully with a soft, wet cloth or chamois. The cloth or chamois must be kept free of grit by frequently rinsing in clean water. Grease and oil can be removed with kerosene. Do not use window cleaners or kitchen scouring compounds. **DO NOT** use solvents such as Acetone, Benzene, Carbon Tetrachloride, and Lacquer Thinners. A spray wax such as Pledge or Maguire's polish can be applied and wiped with a clean soft cloth. The wax tends to fill in and hide small scratches.

Weekly Cleaning

This procedure is recommended on a weekly basis. It may need to be performed more often if necessary to maintain a clean, sanitary case. The case should be cleaned to this procedure before using the first time.

**NOTICE:**

Avoid splashing or soaking any electrical components with water to prevent electrical damage to the case.

**NOTICE:**

Shut off lights and power switches and remove all product from case. Allow sufficient time for the unit to reach room temperature before proceeding with cleaning.

**NOTICE:**

Remove all product from case before proceeding with cleaning procedure.

**NOTICE:**

Acrylic end panels, top panel, lift up doors, and inner doors require special washing procedures to prevent hazing and yellowing of material. Read cleaning of end panel and top panel procedure carefully.

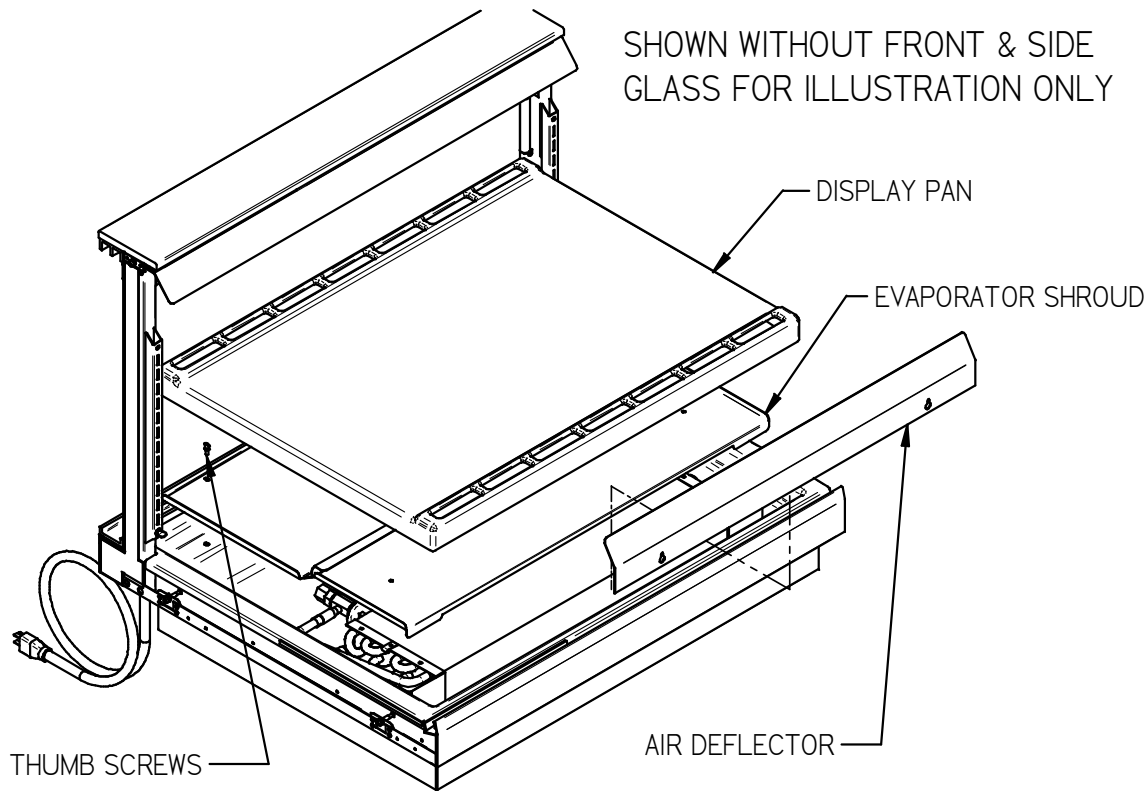

1. Remove both rear doors as described in the "Door Removal" section of this manual.
2. Remove shelving from unit through rear door opening as described in the "Shelving Installation and Removal" section of this manual. Remove all interior shelving as described in the shelving installation and removal section of this manual.
3. Remove both shelf standards from interior of case by removing the (2) thumbscrew from top and bottom.
4. Steps 5 & 6 on refrigerated only.
5. On Refrigerated models lift the display pan up and out of evaporator tub. Remove display pan through rear opening. Remove the evaporator fan shroud by removing the thumbscrews along the backside of evaporator fan shroud and on each end of evaporator coil. Lift the rear of the evaporator fan shroud and reach in and unplug the evaporator fan motor cord. Remove evaporator fan shroud through rear opening.
6. Clean the entire interior of the case using warm soapy water. Wipe off all soapy water with a damp cloth and allow to dry. (DO NOT use solvents such as Acetone, Benzene, Carbon Tetrachloride, and Lacquer Thinners)

NOTE: Depending on the amount of usage and spillage of foreign material, some fasteners may have to be removed and parts disassembled to allow proper cleaning of the unit.

7. Clean all shelves, shelf support bars, shelf lights, shelf brackets, and display pans using warm soapy water and a brush. Rinse thoroughly and allow to dry.
8. Clean all foreign material from inner and outer rear door tracks using warm soapy water and a brush. Apply a light film of lubricant such as PAM to make the doors operate smoother.
9. Clean both sides of the doors and interior and exterior of the front glass using any common window cleaner. IMPORTANT: Do not allow glass cleaner to contact any of the Acrylic plastic end panels, Acrylic plastic top panel, Acrylic plastic front lift up doors, or Acrylic plastic inner doors.
10. IMPORTANT: Cleaning the Acrylic plastic end panels, top panel, front lift-up doors, and plastic inner doors require special care to prevent hazing and yellowing of material. Lightly dust (not wipe) surface with clean soft cloth. Then the surface can be wiped carefully with a soft, wet cloth or

chamois. The cloth or chamois must be kept free of grit by frequently rinsing in clean water. Grease and oil can be removed with kerosene. Do not use window cleaners or kitchen scouring compounds. DO NOT use solvents such as Acetone, Benzene, Carbon Tetrachloride, and Lacquer Thinners. A spray wax such as Pledge or Maguire's polish can be applied and wiped with a clean soft cloth. The wax tends to fill in and hide small scratches.

11. Reassemble the case in reverse order.

SERVICE INFORMATION

CAUTION
RISK OF ELECTRIC SHOCK
DISCONNECT POWER BEFORE
SERVICING UNIT

Before any service work is performed on the case, make sure all power is disconnected to the case.

IMPORTANT: Read this Section of this manual located on page 5. "REFRIGERATION WARNING & INSTALLATION-REPAIR-DECOMMISSIONING"
All refrigeration and electrical work must be performed by certified technicians.

Service problems or request for repair parts from authorized service agencies, trained service personnel, or owners should be referred to:

CUSTOMER SERVICE DEPARTMENT
Federal Industries
215 Federal Avenue
Belleville, WI 53508
Toll Free: (800) 356-4206 / WI Phone (608) 424-3331
Fax: (608) 424-3234

To find a service company in your area, please visit our website at www.federalindustries.com. There you can also find self-service tools to help you get the answers you need faster!

For Warranty Service Requests & ALL Technical Support please contact:

- Phone: (800) 356-4206 and choose the Tech Support/Warranty Option
- Email: Service@federalind.com

For Warranty Compressors please contact the Parts Department:

- Phone: (800) 356-4206 and choose the Warranty Parts Option
- Email: Parts@Federalind.com



Partstown

Federal Industries has partnered with Parts Town for ALL Non-Warranty Part Identification, Pricing, Lead Times, Orders & Freight Quotes. Please contact Parts Town directly if you need parts:

- Website: PartsTown.com
- Email: CustomerService@PartsTown.com
- Phone: 833-809-8188

Pre-Service Checklist

You may avoid the cost and inconvenience of an unnecessary service call by first reviewing this checklist of frequently encountered situations that can cause unsatisfactory case performance.



CAUTION: Before servicing case turn off power at the main breaker of fuse box.

Case Does Not Operate

- Check for disconnected power supply.
- Check for tripped breaker or blown fuse.
- Check that the thermostat is not "off".

Lights Do Not Operate

- Check that light switch is on.
- Check that light cord(s) are tight in the sockets.

Case Temperature Too Warm

- Check that the cold air inlet and outlet slots are not blocked.
- Be sure that the rear doors are closed and tightly sealed.
- Check for a blocked or dirty condenser coil fins.
- Check cold airflow. Lack of adequate cold airflow could be a defective evaporator fan or blocked evaporator coil. Check that paper or foreign material is not blocking evaporator.

If the evaporator coil is blocked due to excessive frost, turn the thermostat knob to the "off" position for approximately one hour to defrost. Excessive frost will buildup if the case is operated with the door open or ajar.

- Check that the display pans are installed properly.
- Is the case installed properly to allow adequate air flow to and from condenser.

Glass Fogging

- Check room ambient – Case is designed to operate in an environment not to exceed 75°F and 55% relative humidity.
- Check case temperature – Case is designed to operate between 38°F and 42°F.
- Check that nothing is placed on the top of the case glass.

Special Service Situations

IMPORTANT: Read this Section of this manual located on page 5.

"REFRIGERATION WARNING & INSTALLATION-REPAIR-DECOMMISSIONING"

All refrigeration and electrical work must be performed by certified technicians

There are rare occasions when the refrigerant charge must be evacuated from a case in order to perform service work. In those situations, Federal Industries recommends that the refrigerant charge be evacuated into a recovery system to prevent the possibility of hydrofluoro olefin (HFO's) from being released into the atmosphere.

If moisture or liquid is observed around or under a Federal Industries case, an immediate investigation should be made by qualified personnel to determine the source of the moisture or liquid. The investigation made should determine if the case is malfunctioning or if there is a simple housekeeping problem.

Moisture or liquid around or under a case is a potential slip/fall hazard for persons walking by or working in the general area of the case. Any case malfunction or housekeeping problem that creates a slip/fall hazard around or under a case should be corrected immediately.

SALE & DISPOSAL

IMPORTANT: Read this Section of this manual located on page 5.

"REFRIGERATION WARNING & INSTALLATION-REPAIR-DECOMMISSIONING"

All refrigeration and electrical work must be performed by certified technicians

Owner Responsibility

If you sell or give away your Federal Industries case you must make sure that all safety labels and the Installation-Service Manual are included with it. If you need replacement labels or manuals, Federal Industries will provide them free of charge. Contact the customer service department at Federal Industries at (800) 356-4206.

The customer service department at Federal Industries should be contacted at the time of sale or disposal of your case so records may be kept of its new location.

If you sell or give away your Federal Industries case and you evacuate the refrigerant charge before shipment. Federal Industries recommends that the charge be evacuated into a recovery system to prevent the possibility of HFO's from being released into the atmosphere.

Refrigerant Recovery/Recycling/Disposal

When recycling or discarding case, refrigerants MUST BE handled according to local, state and federal codes, requirements and regulations.

If disposing of a refrigerated case that uses ozone depleting chemicals in its refrigeration system, make sure the refrigerant is removed by a qualified service technician and properly disposed of.

If you intentionally release refrigerant into the atmosphere, you may be subject to fines or other penalties (under regulation mandated by environmental regulators and/or legislative edict.)

REFRIGERATION & ELECTRICAL DATA

REFRIGERATION AND ELECTRICAL DATA	
	TOTAL AMPS
NON-REFRIGERATED	
CD3628/CD3628SS	1.5
CD4828/CD4828SS	1.5
REFRIGERATED SELF CONTAINED	
CRB3628/CRR3628	6
CRB4828/CRR4828	6
CRB3628SS/CRR3628SS	6
CRB4828SS/CRR4828SS	6
REFRIGERATED REMOTE	
CRB3628R/CRR3628R	3.6
CRB4828R/CRR4828R	3.8
CRB3628SSR/CRR3628SSR	1.5
CRB4828SSR/CRR4828SSR	1.5

MAIN WIRING DIAGRAMS

DRY, SERVICE AND SELF SERVE CASES (120VOLT)

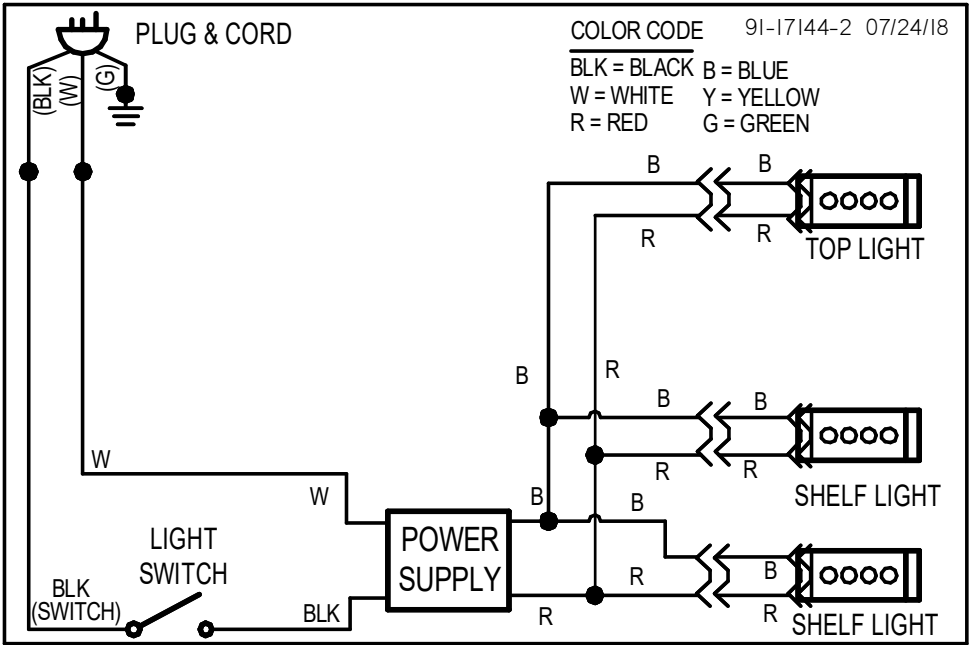

REFRIGERATED SELF CONTAINED, SERVICE CASE (120VOLT)

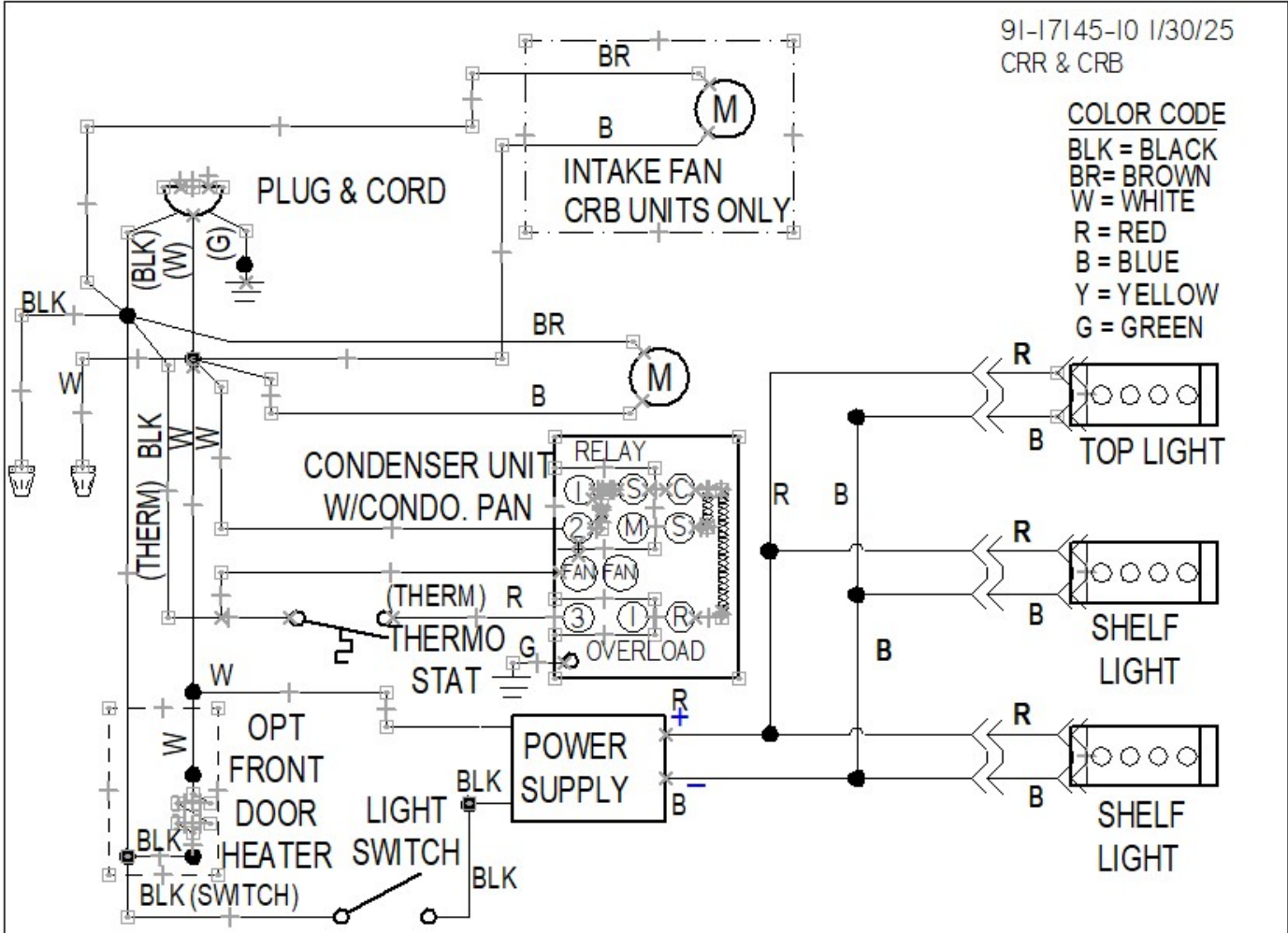

REFRIGERATED REMOTE, SERVICE CASE (120 VOLT)

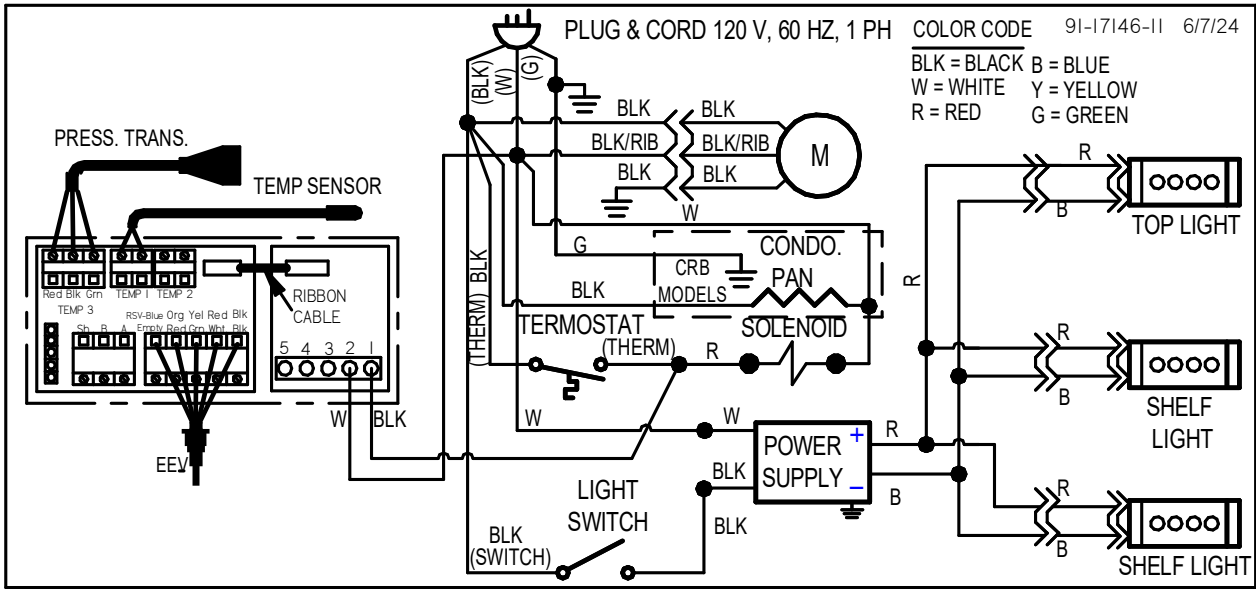

REFRIGERATED REMOTE, SELF SERVE CASE (120 VOLT)

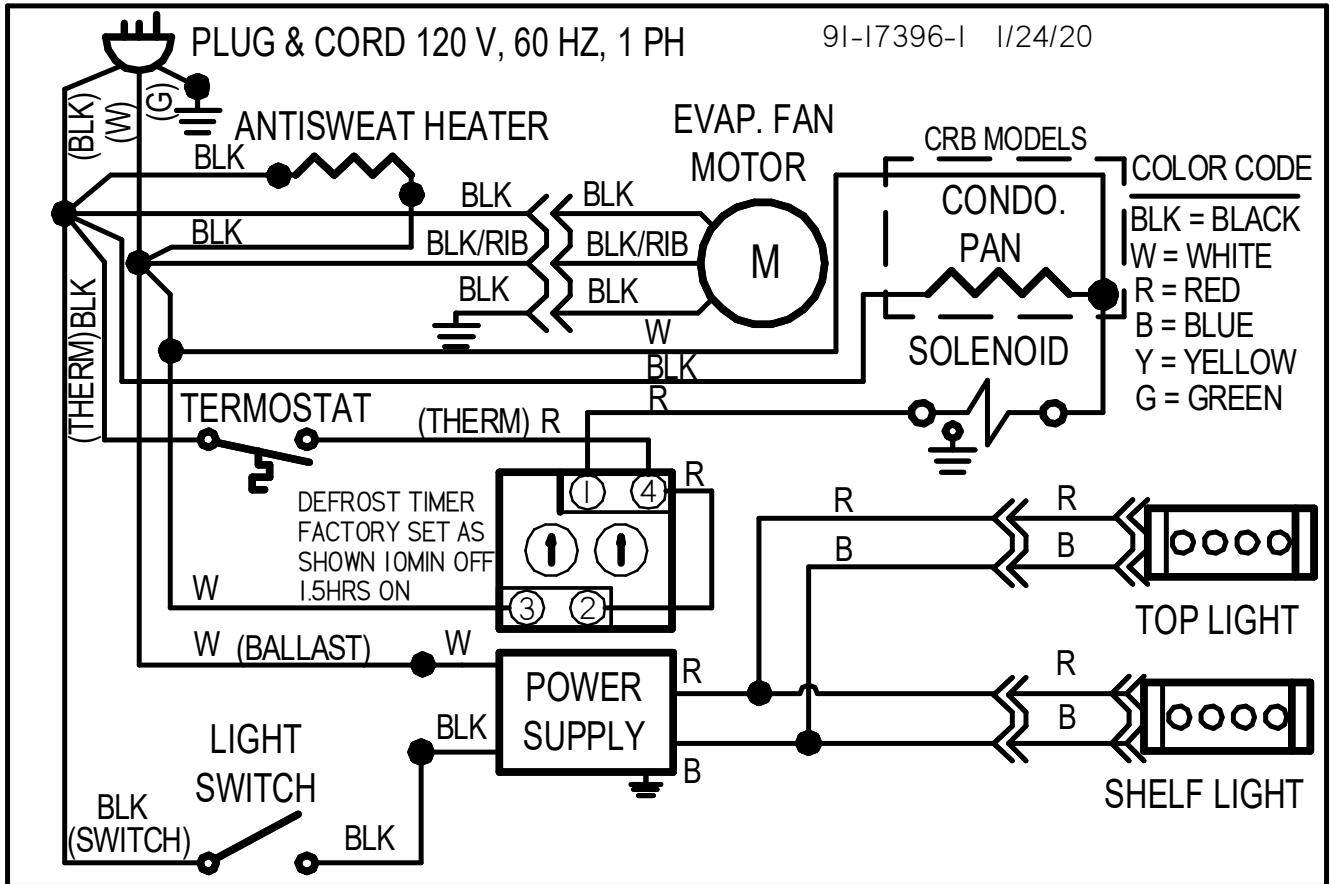

REFRIGERATED REMOTE, SELF SERVE CASE (120 VOLT)

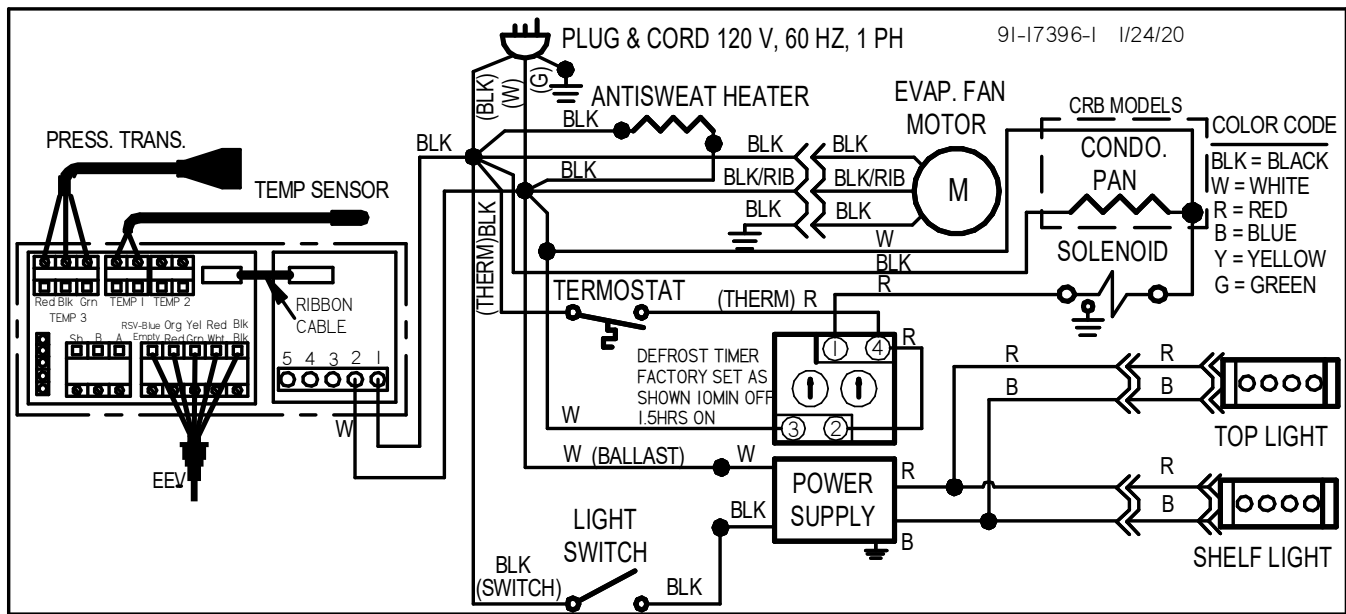

REFRIGERATED REMOTE, SELF SERVE CASE (120 VOLT)

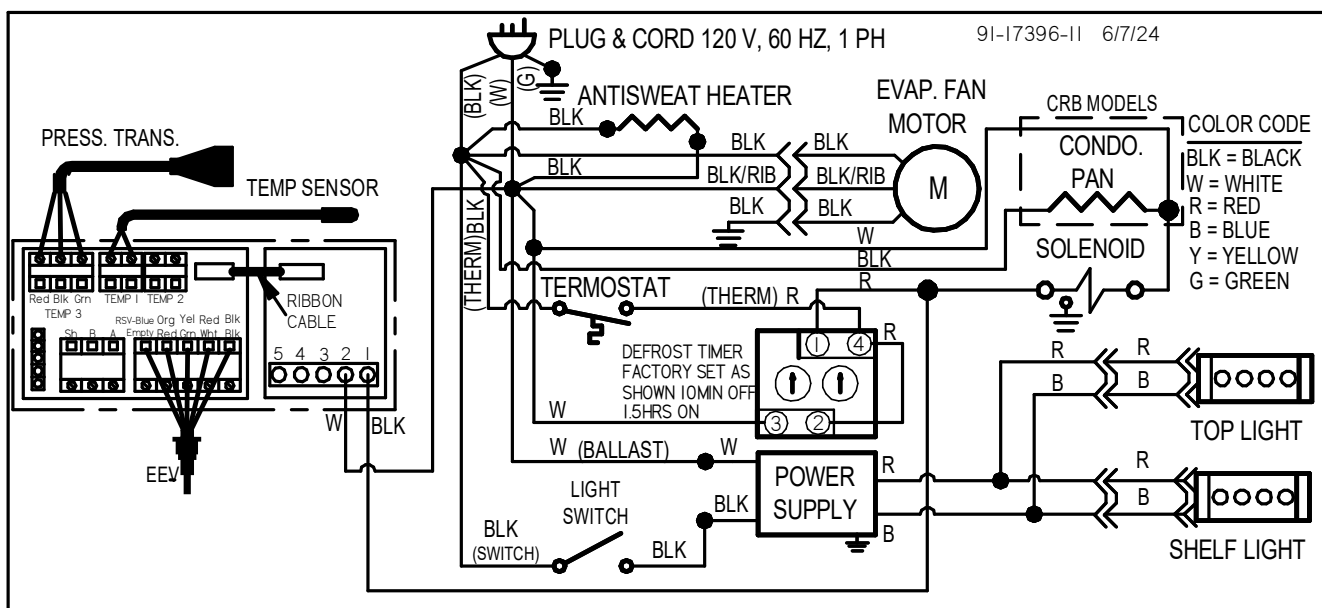

PARTS

SERVICE MODELS

REFRIGERATION	CRB3628	CRB4828	CD3628	CD4828
	CRR3628	CRR4828		
Condensing Unit	30-21744		-	
Condensing Compressor Only	N/A			
Compressor Plug Receptacle	N/A			
Evaporator Coil	33-17315-21	33-17315-22	-	
Expansion Valve	32-21751		-	
Filter Drier	32-21748		-	
Thermometer	32-13662			
Thermostat	32-15495		-	
ELECTRICAL				
Light Switch	41-11066			
Light Power Supply	39-20986			
Light - LED	42-20871-25C35	42-20871-38C35	42-20871-25C35	42-20871-38C35
Top Shelf light Cord	43-20860-4B			
Bottom Shelf light Cord	43-20860-4B			
Lighting Harness	43-20974			
Wiring Diagram	91-17145-1 (SC)/91-17146-1 (REM)		91-17144-2	
Power Cord	43-11302 & 43-30818			
GLASS & SHELVING				
Rear Door Inner Clear	53-16026-1	53-16026-3	53-16026-1	53-16026-3
Rear Door Inner Reflective	53-16026-2	53-16026-4	53-16026-2	53-16026-4
Rear Door Outer Clear	53-16028-1	53-16028-3	53-16028-1	53-16028-3
Rear Door Outer Reflective	53-16028-2	53-16028-4	53-16028-2	53-16028-4
Rear Door Top Track	57-16035-1	57-16035-2	57-16035-1	57-16035-2
Rear Door Bottom Track	57-16034-1	57-16034-2	57-16034-1	57-16034-2
End Panel Clear Left	15-16017	15-16017	51-17130-L	51-17130-L
End Panel Clear Right	15-16017	15-16017	51-17130-R	51-17130-R
End Panel Reflective Left	SA4087-L	SA4087-L	51-17230-L	51-17230-L
End Panel Reflective Right	SA4087-R	SA4087-R	51-17230-R	51-17230-R
Glass Shelf (Optional)	52-17102-1	52-17102-2	52-17102-1	52-17102-2
Glass Shelf Retainer	SA4091	SA4091	SA4091	SA4091
Wire Shelf Black	63-16053-1	63-16053-2	63-16053-1	63-16053-2
Wire Shelf Plastic Clip	64-72570			
Shelf Bracket Top	67-16038-1			
Shelf Bracket Bottom	67-16038-2			
Front Glass Seal	64-17167		-	

SELF-SERVE MODELS	CRB3628SS	CRB4828SS	CD3628SS	CD4828SS
REFRIGERATION	CRR3628SS	CRR4828SS		
Condensing Unit	30-21744		-	
Condensing Compressor Only	N/A		-	
Compressor Plug Receptacle	43-17403		-	
Evaporator Coil	33-17315-1	33-17315-2	-	
Expansion Valve (TXV)	32-12625		-	
Pressure Transducer (EEV)	32-21225		-	
Electronic Expansion Valve	32-21228		-	
Filter Drier	32-12626		-	
Thermometer	32-13662			
Thermostat	32-15495		-	
ELECTRICAL				
Solid State Timer	41-17339		-	
Light Switch	41-11066			
Light Power Supply	39-20986			
LED Light	42-20871-25	-	-	
Top Light Bulb Receptacle	42-15440		42-10833	
Top Shelf Light Cord	43-20860-4B			
Bottom Shelf Light Cord	43-20860-4B			
Lighting Harness	43-21004			
Wiring Diagram SC	91-17395-1			
Wiring Diagram REM	91-17145-2 (Service) 91-17395-2 (SS)		-	
Power Cord	43-11302 & 43-30818			
EEV Control	32-21223			
EEV Temp Probe	32-21224			
GLASS & SHELVING				
Rear Door Inner Clear	53-17390-1	53-17390-3	53-16026-1	53-16026-3
Rear Door Inner Reflective	53-17390-2	53-17390-4	53-16026-2	53-16026-4
Rear Door Outer Clear	53-17391-1	53-17391-3	53-16028-1	53-16028-3
Rear Door Outer Reflective	53-17391-2	53-17391-4	53-16028-2	53-16028-4
Rear Door Top Track	57-17388-1	57-17388-2	57-16035-1	57-16035-2
Rear Door Bottom Track	57-17389-1	57-17389-2	57-16034-1	57-16034-2
Clear Inner Door Ass'y Inner	SA4132-1	SA4132-2	-	
Clear Inner Door Ass'y Outer	SA4131-1	SA4131-2	-	
End Panel Clear Left	15-16017	15-16017	51-17130-L	51-17130-L
End Panel Clear Right	15-16017	15-16017	51-17130-R	51-17130-R
End Panel Reflective Left	SA4087-L	SA4087-L	51-17230-L	51-17230-L
End Panel Reflective Right	SA4087-R	SA4087-R	51-17230-R	51-17230-R
Glass Shelf (Optional)	52-17102-3	52-17102-4	52-17102-1	52-17102-2
Glass Shelf Retainer	SA4091	SA4091	SA4091	SA4091
Shelf Black	M15357-1	M15357-2	63-16053-1	63-16053-2
Wire Shelf Plastic Clip	-		64-72570	
Shelf Bracket Top	67-16038-3		67-16038-1	
Shelf Bracket Bottom	-		67-16038-2	
Shelf Support (2 per case)	M20996-1		M20996-2	
Clear Top Lift Up Door	-		15-16036-1	15-16036-2
Clear Bottom Lift Up Door	-		15-16037-1	15-16037-2
Door Pivot Bushing	-		78-17333	

California Residents Only.

 **WARNING**

This product can expose you to chemicals including chromium which is known to the State of California to cause cancer and birth defects or other reproductive harm. For more information go to

www.P65Warnings.ca.gov

