



The Signature of Quality®

Installation & Operation Instructions

Refrigerated SSRPF & SSRVS Models



Federal Industries
215 Federal AVE
Belleville, WI 53508

Toll Free: (800) 356-4206
WI Phone: (608) 424-3331
Fax: (608) 424-3234





Contents

(1)	Introduction	4
1.1	REGISTRATION & SERIAL NUMBER	4
(2)	Warning Labels & Safety Instructions	5
(3)	refrigeration warning	6
	installation-repair-decommissioning	6
3.1	WARNING SYMBOL.....	6
3.2	DANGER.....	6
3.3	Qualification:	7
3.4	Checks to Area:.....	7
3.5	Repairs to sealed components:	8
3.6	Detection of flammable refrigerants:	9
3.7	Removal and Evacuation:	9
3.8	Charging procedures:	9
3.9	Decommissioning:	9
3.10	Labeling:	10
3.11	Recovery:	10
(4)	Pre-Installation Procedures.....	10
4.1	Inspection for Shipping Damage.....	10
(5)	Base Component LayoutS SELF CONTAINED.....	11
(6)	Base Component LayoutS REMOTES	13
(7)	General Electrical & Grounding.....	15
7.1	Cord Connected.....	15
7.2	Permanent Connected (Option).....	15
7.3	Electrical information	16
7.4	Evaporator Condensate Drain Tube	16
7.5	Condensate Pump.....	17
(8)	Installation Instructions	17
8.1	Locating the Display Case	17
8.2	Removing Case From Shipping Skid and General Installation.....	18
8.3	Cleaning	18
(9)	Shelving Installation & Removal	18
9.1	SHELF BRACKETS AND SUPPORTS INSTALLATION	18
9.2	Solid Shelf Installation.....	20
9.3	Glass Shelf Installation (OPTIONAL).....	20
(10)	SSRPF CASE REAR DOORS (OPTION).....	21
(11)	NIGHT CURTAIN OPERATION	21
(12)	SECURITY NIGHT COVER (OPTION)	23
(13)	Operating Instructions	24

13.1	User Controls Overview.....	24
13.2	Power Switch	24
13.3	Light Switch.....	24
13.4	Electronic Temperature Control.....	24
13.4.1	Button and Display overview	25
13.4.2	Powering on control.....	25
13.4.3	Adjusting the set point	25
13.4.4	Entering Manual Defrost Mode	26
13.4.5	Error codes.....	26
13.5	Electronic Control Operation	27
13.6	Initial Startup.....	27
(14)	Refrigeration Operation.....	28
14.1.1	Remote Models.....	28
14.2	Remote Units There are special requirements for A2L refrigerants such as R454C	30
(15)	Refrigerant detection and mitigation system	32
15.1	Placing Product in Case	34
(16)	MAINTENANCE (LIGHTS).....	34
(17)	Periodic Maintenance (CLEAN CONDENSER)	35
(18)	Cleaning Instructions.....	36
18.1	Daily Cleaning	36
18.2	Weekly Cleaning.....	37
18.3	Weekly Exterior Cleaning.....	38
(19)	Sale & Disposal.....	39
19.1	Owner Responsibility.....	39
(20)	Service Information.....	39
20.1	Special Service Instructions	40
20.2	Pre-Service checklist.....	40
	Lights do not operate.....	40
	Case temperature too warm (product is exceeding 41°F).....	40
20.3	Self Contained WIRING DIAGRAM.....	41
20.4	REMOTE WIRING DIAGRAM	42
(21)	Replacement Parts	43

(1) INTRODUCTION

Thank you for purchasing a Federal Industries display case. This manual contains important instructions for installing and servicing the SSRPF and SSRVS refrigerated self-service merchandisers. A repair parts list and wiring diagram are also included in the manual. Read all of these documents carefully before installing or servicing your case.

	<p>NOTICE Read this manual before installing your case. Keep this manual and refer to it before doing any service on the equipment. Failure to do so could result in personal injury or damage to the case.</p>
	<p>NOTICE Installation and service of the electrical components in the case must be performed by a licensed electrician. The portions of this manual covering components contain technical instructions intended only for persons qualified to perform electrical work.</p>
	<p>DANGER Improper or faulty hookup of electrical components in the case can result in severe injury or death. All electrical wiring hookups must be done in accordance with all applicable local, regional, or national standards.</p>

1.1 REGISTRATION & SERIAL NUMBER

It's important to keep a record of the model and serial number of your merchandiser for warranty and part identification. Please write them here for your quick reference.

Register your product online! Visit our website at www.federalindustries.com and register your product today.

Case Model _____ Serial Number _____

We're here to provide you with the best possible experience with your new product, however, we cannot cover everything about your merchandiser in this manual, so if you have any additional questions or issues, please see the SERVICE INFORMATION PAGE to find who you should contact.

(2) WARNING LABELS & SAFETY INSTRUCTIONS



This is the safety-alert symbol. When you see this symbol on your case or in the manual, be alert to the potential for personal injury or damage to your equipment.

Be sure you understand all safety messages and always follow recommended precautions and safe operating procedures.



NOTICE TO EMPLOYERS:

You must make sure that everyone who installs, uses, or services your case is thoroughly familiar with all safety information and procedures.

Important safety information is presented in this section and throughout the manual. The following signal words are used in the warning and safety messages:

DANGER:	Severe injury or death will occur if you ignore the message.
WARNING:	Severe injury or death can occur if you ignore the message.
CAUTION:	Minor injury or damage to your case can occur if you ignore the message.
NOTICE:	This is important installation, operation, or service information. If you ignore the message, you may damage your case.

The warning and safety labels shown throughout this manual are placed on your Federal Industries case at the factory. Follow all warning label instructions. If any warning or safety labels become lost or damaged, call our customer service department at (800) 356-4206 for replacements.

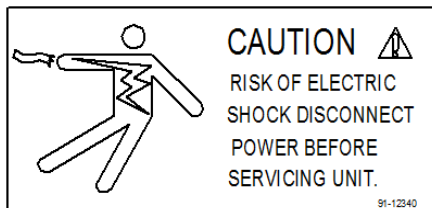

This label is located on the back of the display case

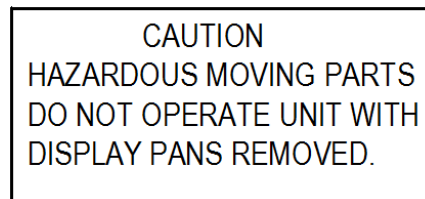

This label is located below the display pan.

DANGER – Risk of fire or explosion. Flammable refrigerant used. Consult repair manual/owner's guide before attempting to service this product. all safety precautions must be followed 91-21814

DANGER — Risque d'incendie ou d'explosion. Fluide frigorigène utilisé. Consulter le guide propriétaire ou le manuel de réparations avant de d'essayer d'installer ou de réparer ce produit. Toutes les précautions de sécurité doivent être suivies. 91-21814

This label is located by condensing unit

(3) REFRIGERATION WARNING

INSTALLATION-REPAIR-DECOMMISSIONING



3.1 WARNING SYMBOL

This is the Danger-Flammable symbol. When you see this symbol on your case or in the manual, be alert to the potential for risk of fire or explosion.

Be sure you understand all safety messages and always follow recommended precautions and safe operating procedures.

3.2 DANGER



Risk of fire or explosion. Flammable refrigerant used. To be repaired only by trained service personnel. Do not puncture refrigerant tubing. Dispose of properly in accordance with federal or local regulations

Consult repair manual/owner's guide before attempting to service this product. All safety precautions must be followed.

Follow handling instructions carefully in compliance with national regulations.

Auxiliary devices which may be ignition sources shall not be installed in the ductwork, other than auxiliary devices listed for use with the specific appliance.

Do not store explosive substances (such as aerosol cans with a flammable propellant) in this case.

Do not use an electrical appliance INSIDE the food storage compartments unless its type is recommended by manufacturer.

Flammable refrigerant type specified on case nameplate is on the serial label.

APPLIES TO R290 REFRIGERANT MODELS ONLY! Contains a charge of R290 refrigerant with a lower flammability limit (LFL) of .038kg/m³. See data plate for amount of charge.

APPLIES TO R454C REFRIGERANT MODELS ONLY! Contains a charge of R454C refrigerant with a lower flammability limit (LFL) of .286kg/m³. See data plate for amount of charge.

WARNING

- Do not use means to accelerate the defrosting process or to clean, other than those recommended by the manufacturer.
- The appliance shall be stored in a room without continuously operating ignition sources
For example: open flames, an operating gas appliance or an operating electric heater.
- Do not pierce or burn.
- Be aware that refrigerants may not contain an odor.

MISE EN GARDE

- Ne pas utiliser de moyens autres que ceux recommandés par le fabricant pour accélérer le processus de dégivrage ou pour nettoyer l'appareil.
- L'appareil doit être entreposé dans un local ne contenant pas de sources d'inflammation permanentes (flammes nues, appareil à gaz ou dispositif de chauffage électrique en fonctionnement, par exemple).
- Ne pas percer ou brûler.
- Attention, les fluides frigorigènes peuvent ne pas dégager d'odeur.

3.3 QUALIFICATION: ALL refrigeration and electrical maintenance, service, and repair must be performed by a Certified Technician that is trained in the required flammable refrigerants safety procedures. Technicians must read the entire section “REFRIGERATION WARNINGS SECTION” of this manual.

Including but not limited to the following:

- a) breaking into the refrigerating circuit.
- b) opening of sealed components.
- c) opening of ventilated enclosures.

3.4 CHECKS TO AREA: Prior to beginning work on systems containing FLAMMABLE REFRIGERANTS, safety checks are necessary to ensure that the risk of ignition is minimized prior to conducting work on the system.

- Capacitors are discharged: this shall be done in a safe manner to avoid possibility of sparking.
- No live electrical components and wiring are exposed while charging, recovering or purging the system.
- Continuity of earth bonding.
- Work shall be undertaken under a controlled procedure to minimize the risk of a flammable gas or vapor being present while the work is being performed.
- All maintenance staff and others working in the local area shall be instructed on the nature of the work being carried out. Work in confined spaces shall be avoided.
- The area shall be checked with an appropriate refrigerant detector prior to and during work, to ensure the technician is aware of potentially toxic or flammable atmospheres. Ensure that the leak detection equipment being used is suitable for use with all applicable refrigerants, i.e., non-sparking, adequately sealed, or intrinsically safe.

-If any hot work is to be conducted on the refrigerating equipment or any associated parts, appropriate fire extinguishing equipment shall be available on hand. A dry chemical or CO2 fire extinguisher should be adjacent to the charging area.

-No person carrying out work in relation to a REFRIGERATING SYSTEM which involves exposing any pipe work shall use any sources of ignition in such a manner that it may lead to the risk of fire or explosion. All possible ignition sources, including cigarette smoking, should be kept sufficiently far away from the site of installation, repairing, removing and disposal, during which refrigerant can possibly be released to the surrounding space. Prior to work taking place, the area around the equipment shall be surveyed to make sure that there are no flammable hazards or ignition risks. "No Smoking" signs shall be displayed.

-Ensure that the area is in the open or that it is adequately ventilated before breaking into the system or conducting any hot work. A degree of ventilation shall continue during the period that the work is carried out. The ventilation should safely disperse any released refrigerant and preferably expel it externally into the atmosphere.

-Where electrical components are being changed, they shall be fit for the purpose and to the correct specification so as to minimize the risk of possible ignition due to incorrect parts. At all times, the manufacturer's maintenance and service guidelines shall be followed. If in doubt, consult the manufacturer's technical department for assistance. The following checks shall be applied to installations using flammable refrigerants:

- a) the actual REFRIGERANT CHARGE is in accordance with the room size within which the refrigerant containing parts are installed.
- b) The ventilation machinery and outlets are operating adequately and are not obstructed.
- c) Markings of the equipment continue to be visible and legible. Markings and signs that are illegible shall be corrected.
- d) Refrigerating pipes or components are installed in a position where they are unlikely to be exposed to any substance which may corrode refrigerant containing

-Repair and maintenance to electrical components shall include initial safety checks and component inspection procedures. If a fault exists that could compromise safety, then no electrical supply shall be connected to the circuit until it is satisfactorily dealt with. If the fault cannot be corrected immediately but it is necessary to continue operation, an adequate temporary solution should be used. This shall be reported to the owner of the Initial safety checks shall include:

3.5 REPAIRS TO SEALED COMPONENTS:

-During repairs to sealed components, all electrical supplies shall be disconnected from the equipment being worked upon prior to any removal of sealed covers, etc. If it is necessary to have an electrical supply to equipment during servicing, then a permanently operating form of leak detection shall be located at the most critical point to warn of a potentially hazardous situation.

-Particular attention shall be paid to the following to ensure that by working on electrical components, the casing is not altered in such a way that the level of protection is affected. This shall include damage to cables, excessive number of connections, terminals not made to original specification, damage to seals, incorrect fitting of glands, etc. Ensure that the apparatus is mounted securely. Ensure that seals or sealing materials have not degraded to the point that they no longer serve the purpose of preventing the egress of flammable atmospheres. Replacement parts shall be in accordance with the manufacturer's specifications.

-Do not apply any permanent inductive or capacitance loads to the circuit without ensuring that this will not exceed the permissible voltage and current permitted for the equipment in use.

NOTE The use of silicon sealants can inhibit the effectiveness of some types of leak detection equipment. Intrinsically safe components do not have to be isolated prior to working on them.

3.6 DETECTION OF FLAMMABLE REFRIGERANTS:

Under no circumstances shall potential ignition sources be used in the searching for or detection of refrigerant leaks. A halide torch (or any other detector using a naked flame) shall not be used.

The following leak detection methods are deemed acceptable for all refrigerant systems:

-Electronic leak detectors may be used to detect refrigerant leaks but, in the case of FLAMMABLE REFRIGERANTS, the sensitivity might not be adequate or might need recalibration. (Detection equipment shall be calibrated in a refrigerant-free area.) Ensure that the detector is not a potential source of ignition and is suitable for the refrigerant used. Leak detection equipment shall be set at a percentage of the LFL of the refrigerant and shall be calibrated to the refrigerant employed, and the appropriate percentage of gas (25 % maximum) is confirmed.

-Leak detection fluids are also suitable for use with most refrigerants but the use of detergents containing chlorine shall be avoided as the chlorine can react with the refrigerant and corrode the copper pipework.

NOTE Examples of leak detection fluids are

– bubble method,

– fluorescent method agents.

If a leak is suspected, all naked flames shall be removed/extinguished.

If a leakage of refrigerant is found which requires brazing, all the refrigerants shall be recovered from the system, or isolated (by means of shut off valves) in a part of the system remote from the leak.

3.7 REMOVAL AND EVACUATION:

When breaking into the refrigerant circuit to make repairs-or for any other purpose-conventional procedures shall be used. However, for flammable refrigerants it is important that the best practice be followed, since flammability is a consideration. The following procedure shall be adhered to:

- a. Safely remove refrigerant following local and national regulations.
- b. Purge the circuit with inert gas.
- c. Evacuate (optional for A2L).
- d. Purge with inert gas (optional for A2L).
- e. Open the circuit by cutting or brazing.

The refrigerant change shall be recovered into the correct recovery cylinders if venting is not allowed by local and national codes. For appliances containing flammable refrigerants, the system shall be purged with oxygen-free nitrogen to render the appliance safe for flammable refrigerants. This process might need to be repeated several times. Compressed air or oxygen shall not be used for purging refrigerant systems. For appliances containing flammable refrigerants, refrigerant purging shall be achieved by breaking the vacuum in the system with oxygen-free nitrogen and continuing to fill until the working pressure is achieved, then venting to atmosphere, and finally pulling down to a vacuum (optional for A2L). This process shall be repeated until no refrigerant is within the system (optional for A2L). When the final oxygen-free nitrogen change is used, the system shall be vented down to atmospheric pressure to enable work to take place. Ensure that the outlet for the vacuum pump is not close to any potential ignition sources and that ventilation is available.

3.8 CHARGING PROCEDURES:

In addition to conventional charging procedures, the following requirements shall be followed.

- a. Ensure that contamination of different refrigerants does not occur when using charging equipment. Hoses or lines shall be as short as possible to minimize the amount of refrigerant contained in them.
- b. Cylinders should be kept in an appropriate position according to the instructions.
- c. Ensure that the REFRIGERATING SYSTEM is earthed prior to charging the system with refrigerant.
- d. Label the system when charging is complete (if not already).
- e. Extreme care shall be taken not to overfill the REFRIGERATING SYSTEM.

3.9 DECOMMISSIONING:

Before carrying out this procedure, it is essential that the technician is completely familiar with the equipment and all its details. It is recommended good practice that all refrigerants are recovered safely. Prior to the task being carried out, an oil and refrigerant sample shall be taken in case analysis is required prior to re-use of recovered refrigerant. It is essential that electrical power is available before the task commences.

- a. Become familiar with the equipment and its operation.
- b. Isolate the system electrically.
- c. Before attempting the procedure, ensure that:
 - i. Mechanical handling equipment is available, if required, for handling refrigerant cylinders.
 - ii. All personal protective equipment is available and is being used correctly.
 - iii. The recovery process is supervised at all times by a competent person.
 - iv. Recovery equipment and cylinders conform to the appropriate standards.
- d. Pump down the refrigerant system, if possible.
- e. If a vacuum is not possible, make a manifold so that refrigerant can be removed from various parts of the system.
- f. Make sure that the cylinder is situated on the scales before recovery takes place.
- g. Start the recovery machine and operate in accordance with instructions.
- h. Do not overfill cylinders (no more than 80% volume liquid charge).
- i. Do not exceed the maximum working pressure of the cylinder, even temporarily.
- j. When the cylinders have been filled correctly and the process completed, make sure that the cylinders and the equipment are removed from the site properly and all isolation valves on the equipment are closed off.
- k. Recovered refrigerant shall not be charged into another refrigerating system unless it has been cleaned and checked.

3.10 LABELING:

Equipment shall be labeled stating that it has been de-commissioned and emptied of refrigerant. The label shall be dated and signed. For appliances containing flammable refrigerants, ensure that there are labels on the equipment stating the equipment contains flammable refrigerant.

3.11 RECOVERY:

When removing the refrigerant from a system, either for servicing or decommissioning, it is recommended good practice that all refrigerants are removed safely.

When transferring refrigerant into cylinders, ensure that only appropriate refrigerant recovery cylinders are employed. Ensure that the correct number of cylinders for holding the total system charge is available. All cylinders to be used are designated for the recovered refrigerant and labeled for that refrigerant (i.e., special cylinders for the recovery of refrigerant). Cylinders shall be complete with pressure-relief valve and associated shut-off valve in good working order. Empty recovery cylinders are evacuated and, if possible, cooled before recovery occurs.

The recovery equipment shall be in good working order with a set of instructions concerning the equipment that is at hand and shall be suitable for the recovery of all appropriate refrigerants including, when applicable, FLAMMABLE REFRIGERANTS. In addition, a set of calibrated weighing scales shall be available and in good working order. Hoses shall be complete with leak-free disconnect coupling and in good condition. Before using the recovery machine, check that it is in satisfactory working order, has been properly maintained and that any associated electrical components are sealed to prevent ignition in the event of refrigerant release. Consult manufacturer if in doubt.

The recovered refrigerant shall be returned to the refrigerant supplier in the correct recovery cylinder, and the relevant waste transfer note arranged. Do not mix refrigerants in recovery units and especially not in cylinders.

If compressors or compressor oils are to be removed, ensure that they have been evacuated to an acceptable level to make certain that FLAMMABLE REFRIGERANT does not remain within the lubricant. The evacuation process shall be carried out prior to returning the compressor to the suppliers. Only electric heating to the compressor body shall be employed to accelerate this process. When oil is drained from a system, it shall be carried out safely.

(4) PRE-INSTALLATION PROCEDURES

4.1 INSPECTION FOR SHIPPING DAMAGE

You are responsible for filing all freight claims with the delivering truck line. Inspect all cartons and crates for damage as soon as they arrive. If damage is noted to shipping crates, cartons, or if a shortage is found, note this on the bill of lading (all copies) prior to signing.

If damage is discovered when the case is uncrated, immediately call the delivering truck line and follow up the call with a written report indicating concealed damage to your shipment. Ask for an immediate inspection of your concealed damage item. Crating material must be retained to show the inspector from the truck line.

(5) BASE COMPONENT LAYOUTS SELF CONTAINED

SSRPF3652/SSRVS3642

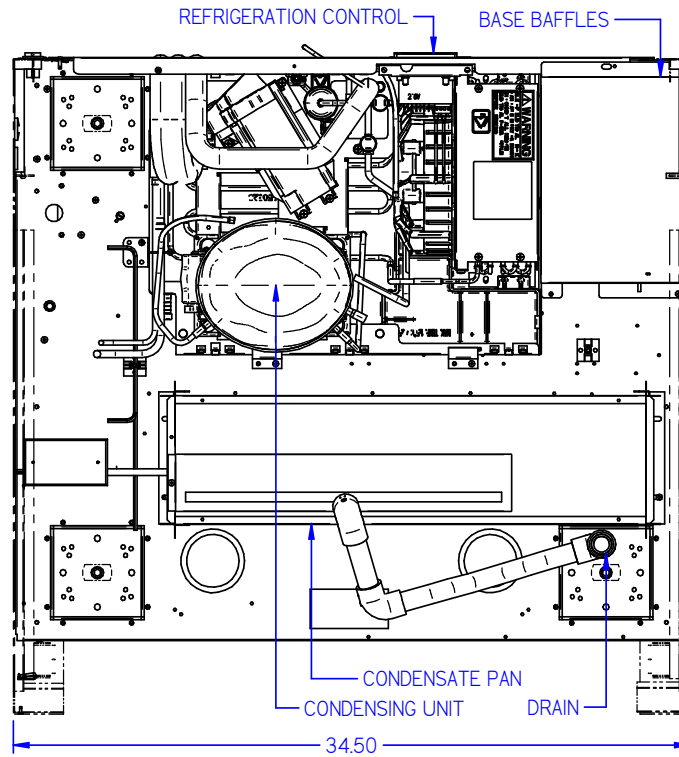

SSRPF5052/SSRVS5042

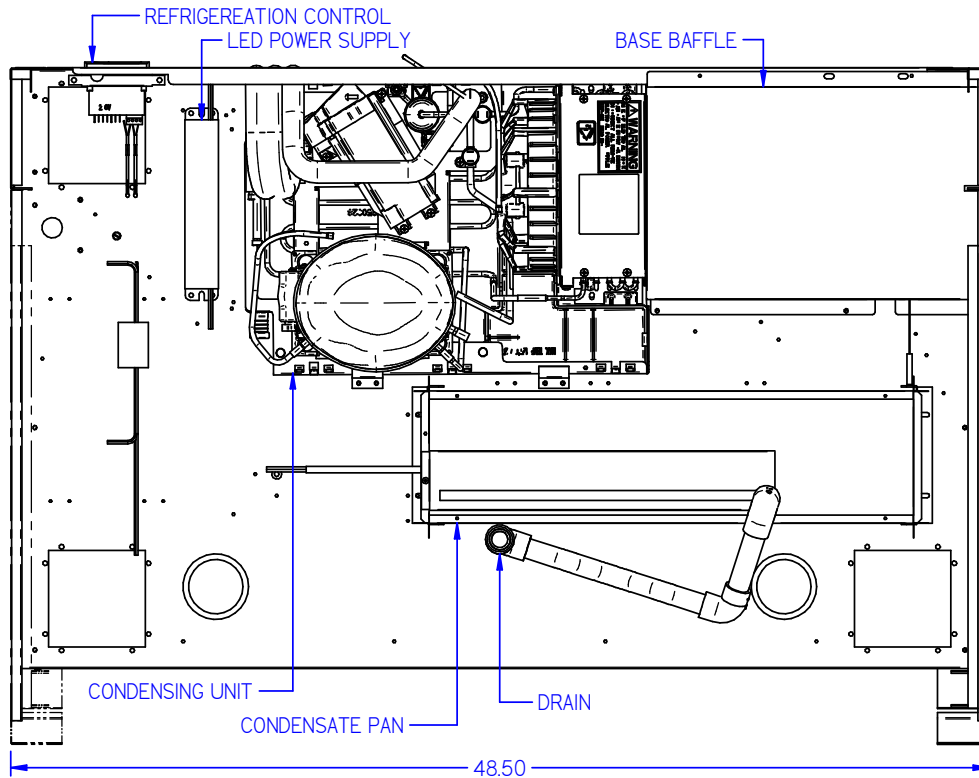

SSRPF5952/SSRVS5942

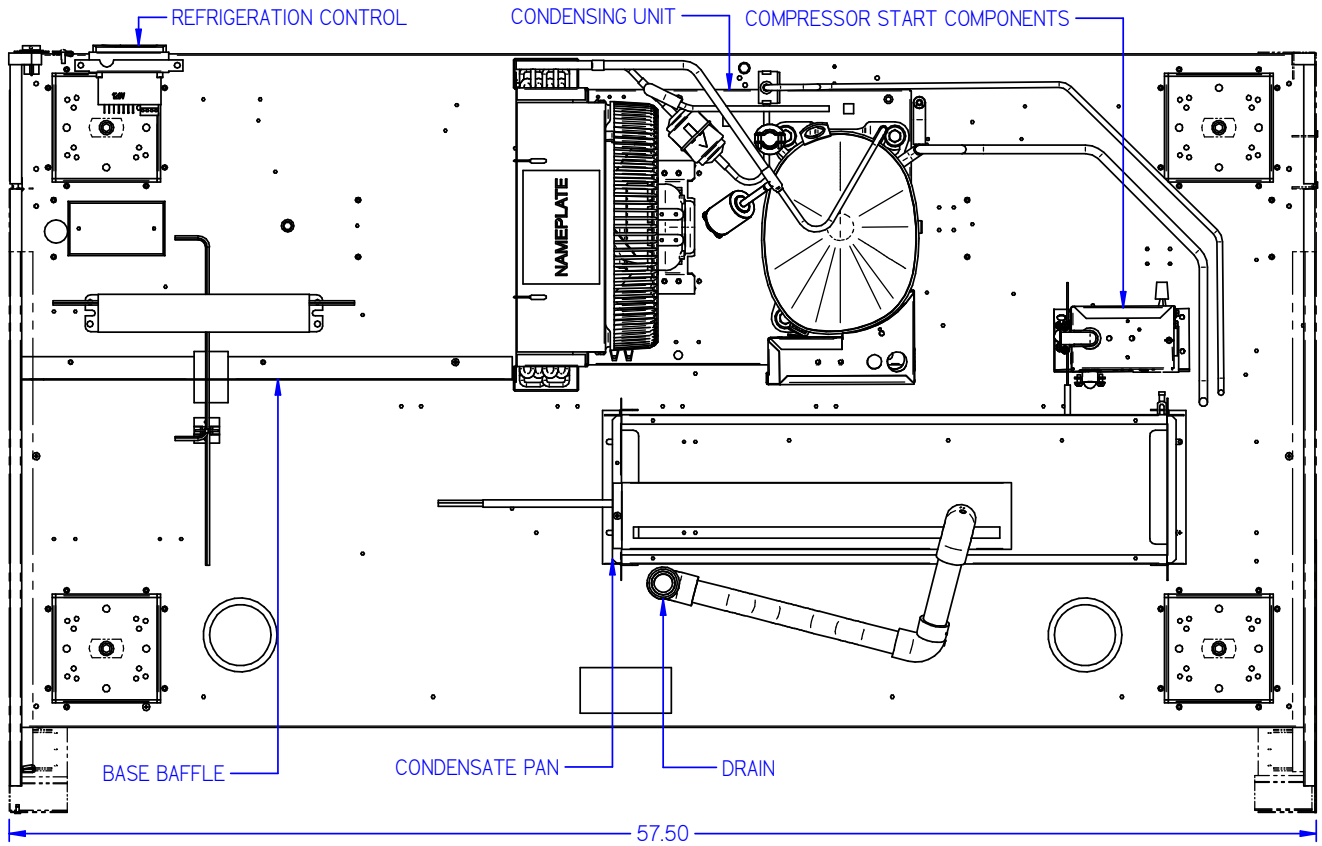

SSRPF7752/SSRVS7742

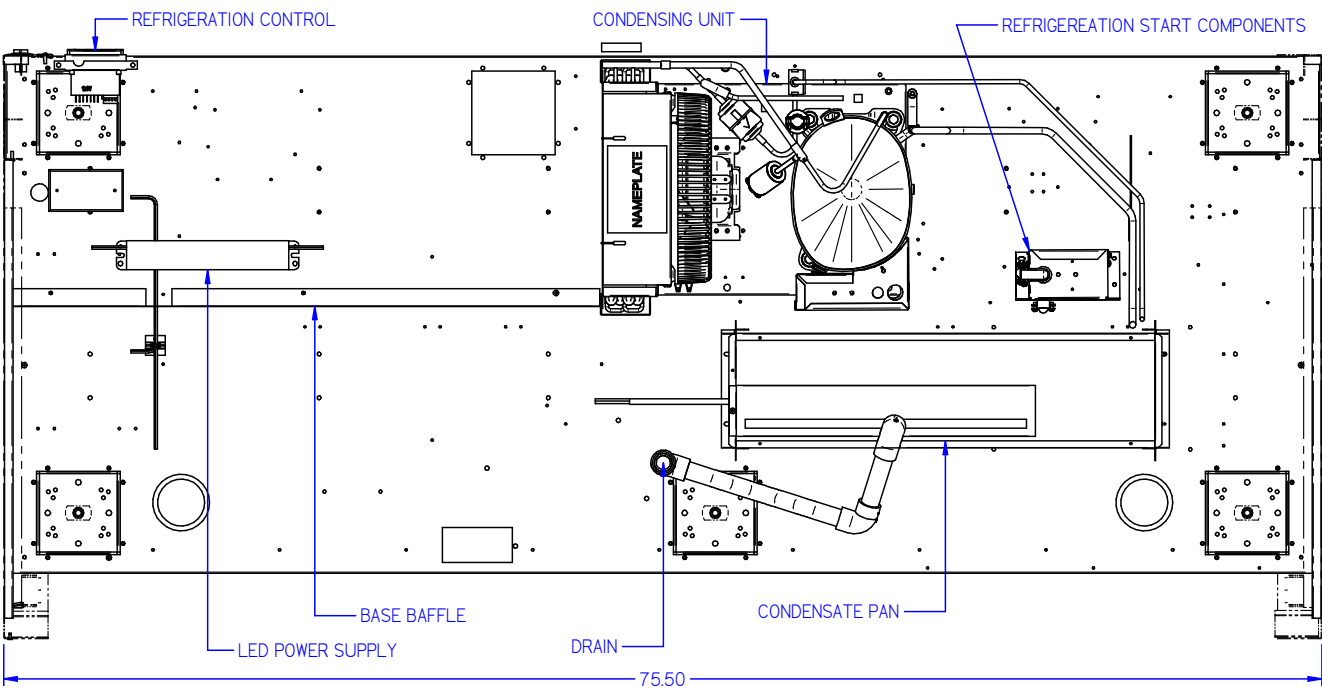

(6) BASE COMPONENT LAYOUTS REMOTES

SSRPF5052R

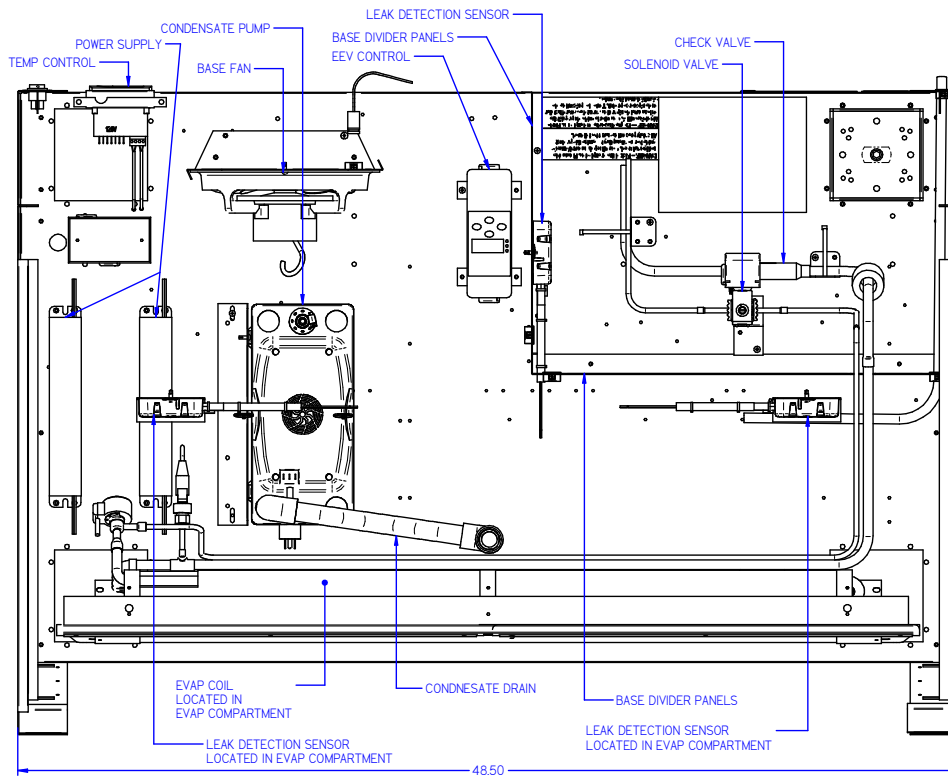

SSRPF5952R

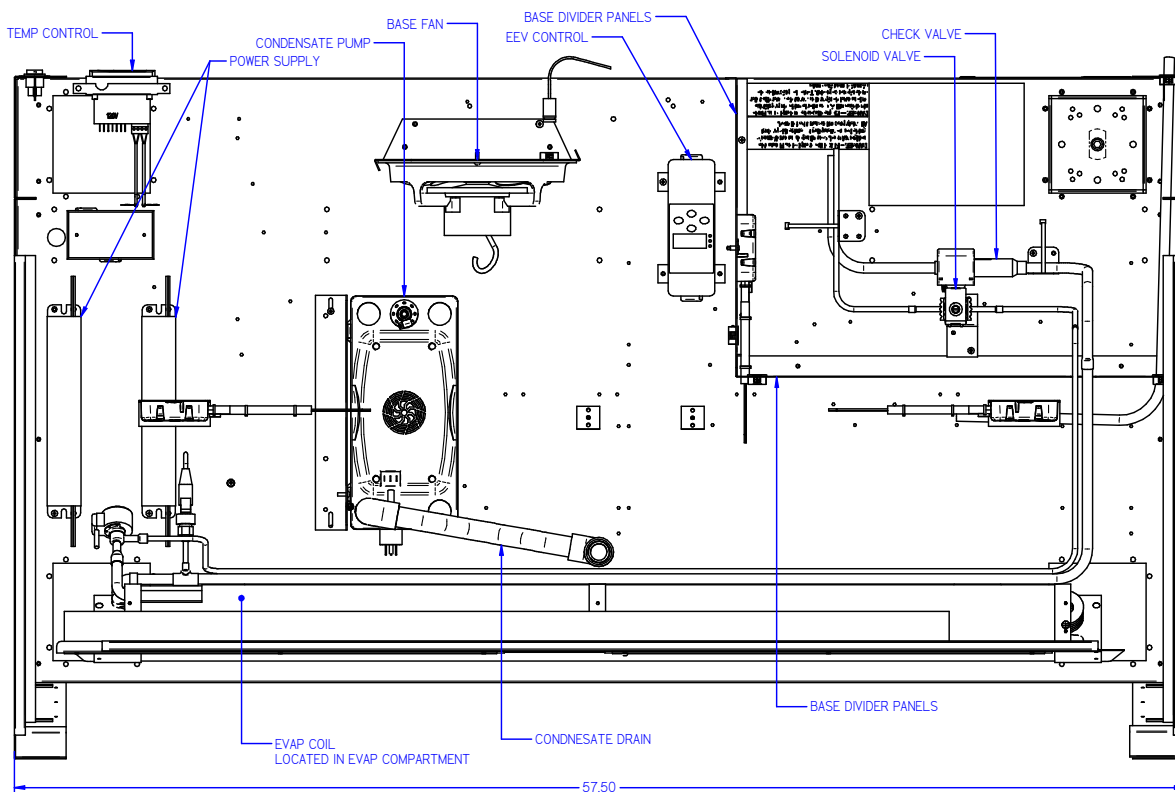

SSRPF7752R

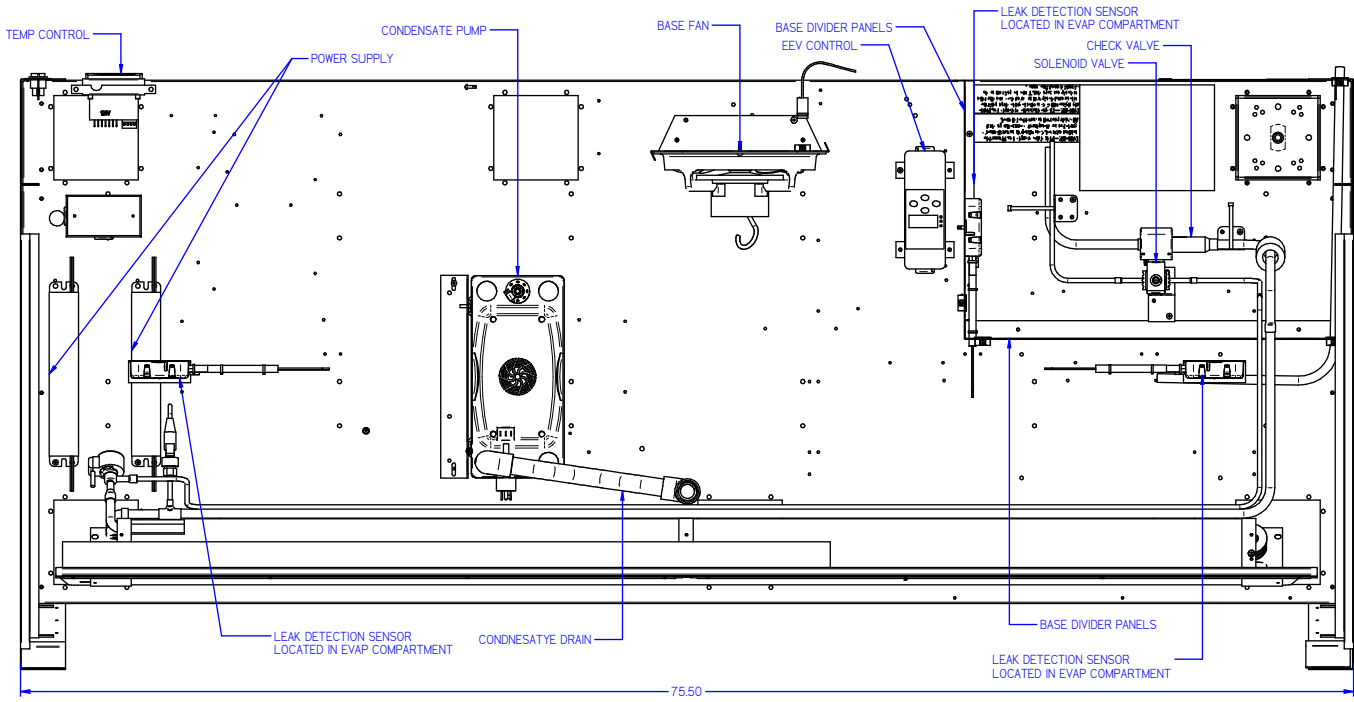

(7) GENERAL ELECTRICAL & GROUNDING



DANGER:

Improper or faulty hookup of electrical components in the display case can result in severe injury or death.

IMPORTANT: Read this Section of this manual located on pages 6 thru 10.

“REFRIGERATION WARNING & INSTALLATION-REPAIR-DECOMMISSIONING”

All refrigeration and electrical work must be performed by certified technicians.

7.1 CORD CONNECTED

All standard models are supplied with a power cord that is properly sized to the amperage requirements of the case. See the electrical data plate located on the rear left interior of the case for the proper circuit size for each case.

The cord is factory installed protruding from the bottom rear corner of the case.

A separate circuit for each display case is required to prevent other appliances on the same circuit from overloading the circuit and causing malfunction.

7.2 PERMANENT CONNECTED (OPTION)

Only a licensed electrician must perform all case electrical connections.

All electrical wiring hookups must be done in accordance with all applicable local, regional, or national electrical standards.

A separate circuit for each display case is required to prevent other appliances on the same circuit from overloading the circuit and causing malfunction.

The electrical service must be grounded upon installation.

See the electrical data plate located at the rear of the case for proper circuit size and wire ampacity.

The electrical connection box is accessible from the rear of the case with rear grill removed.

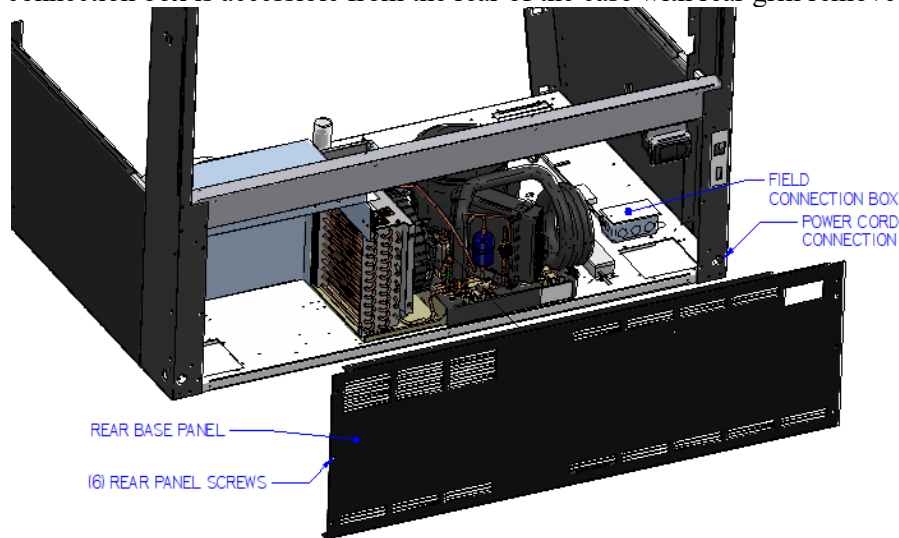

7.3 ELECTRICAL INFORMATION

E3555-1 EXCEL

R454c PERMANENTLY CONNECTED					
MODEL	SELF CONTAINED			REMOTE	
	VOLTAGE	TOTAL AMPS	MAX FUSE SIZE	VOLTAGE	MAX FUSE SIZE
SSRPF3652/ SSRVS3642	120/60/1	12.7	20	N/A	N/A
SSRPF5052/ SSRVS5042	230/60/1	7	15	120/60/1	15
SSRPF5952/ SSRVS5942	230/60/1	7.5	15	120/60/1	15
SSRPF7752/ SSRVS7742	230/60/1	7.5	15	120/60/1	15

R290 CORD CONNECTED OPTIONAL			
MODEL	SELF CONTAINED		
	VOLTAGE	TOTAL AMPS	CORD STYLE
SSRPF3652/ SSRVS3642	120/60/1	12.7	20AMP NEMA 5-20
SSRPF5052/ SSRVS5042/	230/60/1	7	15AMP NEMA 6-15
SSRPF5952/ SSRVS5942	230/60/1	7.5	15AMP NEMA 6-15
SSRPF7752/ SSRVS7742	230/60/1	7.5	15AMP NEMA 6-15

7.4 EVAPORATOR CONDENSATE DRAIN TUBE

	<p>WARNING TO INSTALLER: Evaporator Condensate Drain Tube may become dislodged during shipping. Installer must check Evaporator Condensate Drain Tube upon installation to be sure drain tube is properly seated and installed correctly.</p>
---	--

Evaporator Drain Tube must be attached to tube protruding from bottom of Evaporator Tub and must either be inside the Condensate Pan area or inside of hole of Condensate Pump.

7.5 CONDENSATE PUMP

A condensate pump is Standard on some models and Optional on all models. Installer must check unit to see if a condensate pump has been provided with case.

	<p>WARNING TO INSTALLER: Installer must determine if case was provided with condensate pump. Failure to hook up pump hose to drain will cause water on floor and cause a slip hazard.</p>
---	--

Instead of using heat energy to remove condensate run off from the evaporator coil a condensate pump moves the water to a nearby drain.

- The Condensate Pump is provided with 50ft of clear 1/2in OD x 3/8in ID tubing that must be run out of the base area to a drain.
- There are several drain tube exit locations provided in the base as noted in the drawing above. Plugs or caps will need to be removed in the desired exit location.
- The hose can be run the entire 50ft in any direction as required, but no higher than 20ft from the pump base. A check valve is provided in the pump to prevent water from flowing back into the reservoir. For best efficiency extend the hose level below the level of the pump base to create a siphoning effect. Never run the hose to or through an area below freezing (32°F, 0°C) or freezing water will block the tube.

(8) INSTALLATION INSTRUCTIONS

IMPORTANT: Read this Section of this manual located on page 6 thru 10
 “REFRIGERATION WARNING & INSTALLATION-REPAIR-DECOMMISSIONING”
 All refrigeration and electrical work must be performed by certified technicians.

The installation of the appliance and the refrigerant must only be performed by Federals approved Service or suitably qualified person.

Appliance to be installed in accordance with safety standards ANSI/ASHREA 15.
 The appliance shall not be installed in public corridors or lobbies.

This case is designed for a class 2 environment.

<u>Test room climate class</u>	<u>Dry bulb temperature [°F]</u>	<u>Relative Humidity [%]</u>	<u>Dew point [°F]</u>	<u>Water vapour mass in dry air [lbm water/lbm air]</u>	<u>Required Test Lab Temperature [°F]</u>
2.0	71.6	65	59.36	0.0108	89.6

NSF TYPE 2 Temperature cannot exceed 75 deg F and 55% humidity.

8.1 LOCATING THE DISPLAY CASE

The case should be located where it is not subjected to the direct rays of the sun, heating ducts, grills, radiator, or ceiling fans, nor should it be located near open doors or main door entrances. Also, avoid locations where there are excessive air movement or air disturbances.

The case requires a minimum of 21 inches of clearance at the rear of the unit for air discharge in the 36 and 50 case and 12 inches in the 59 and 77 case. Do not locate case with back tight against the wall.

No clearance is needed on sides of the unit.

8.2 REMOVING CASE FROM SHIPPING SKID AND GENERAL INSTALLATION



CAUTION:

Do not push or pull against the top end glass, or door frames and do not pull on end panels when removing the case from the skid or moving the case. Case damage or glass breakage will result.

1. Remove crate top and sides and note missing or damaged items as explained in the pre-installation procedures outlined above.
2. Move the case as near as possible to the final location and before removing it from the shipping skid.
3. Remove the (4) brackets that secure the case to the shipping skid.
4. Prepare cabinet according to instructions in this section that pertain to your model.
5. Lift the case off of skid and into required position. Only lift the case from under the rear lip and front bottom trim channel above the base. Note: Do not push or pull on front bottom trim channel.
6. The case must be level for proper drainage of defrost condensate to the condensate evaporator. Using the wrench provided level and square the case as needed by adjusting the leg leveler in each corner of base. The 6ft cases also have a set of leg levelers in the center. These must be adjusted so the base is flat.
7. The leveled case must be sealed to the floor using a NSF listed sealant.

8.3 CLEANING

For initial setup, clean the case as outlined in the “Weekly Cleaning” section of this manual.

(9) SHELVING INSTALLATION & REMOVAL

9.1 SHELF BRACKETS AND SUPPORTS INSTALLATION

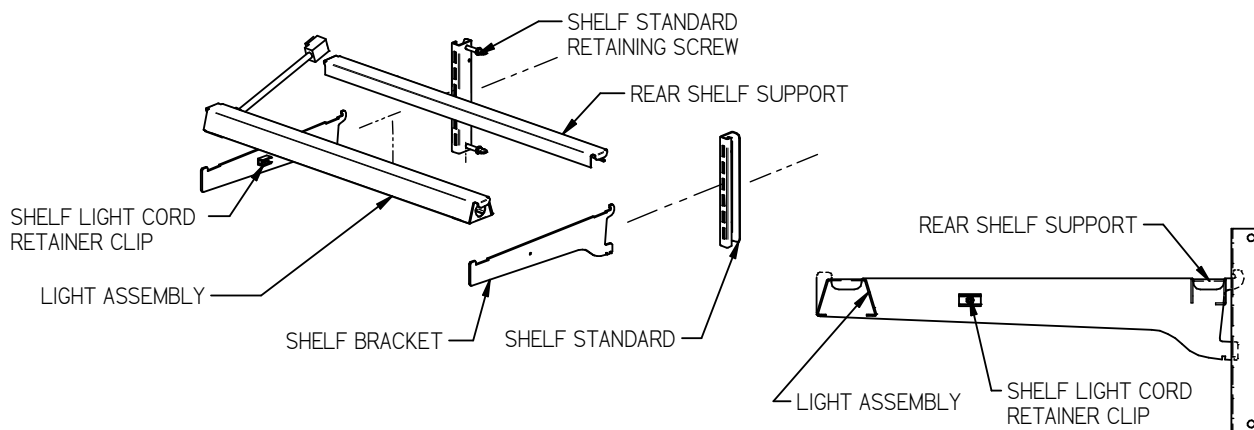

1. Turn the light switch to the off position.
2. Follow the instructions in the illustration below and insert (1) of the shelf brackets in the desired shelf standard slot on one side of the case. Place the additional bracket in the same shelf standard slot on the opposite end of case. The bracket with a clear plastic cord retainer clip must be on the side with the shelf light.

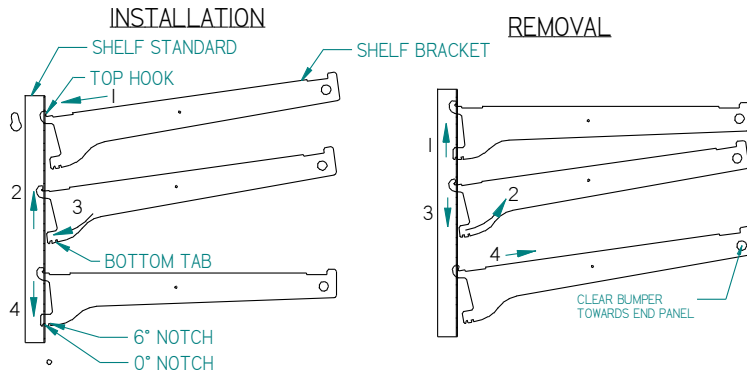

- | | |
|---|--|
| <ol style="list-style-type: none"> 1. Place shelf bracket top hook into desired shelf standard slot. 2. Lift shelf bracket top hook to allow shelf bracket bottom tab to clear shelf standard slot. 3. Swing shelf bracket bottom tab into shelf standard slot. 4. Place the desired shelf bracket notch of 0, 6, or 12 degrees onto bottom of shelf standard slot. | <ol style="list-style-type: none"> 1. Lift shelf bracket up to allow shelf bracket notch to clear the bottom of shelf standard slot. 2. Swing shelf bracket bottom tab out of shelf standard slot. 3. Drop shelf bracket down to allow shelf bracket top hook to clear top of shelf standard slot. 4. remove shelf bracket top from shelf standard slot. |
|---|--|

3. Hang one end of the shelf light housing on the front notch of a shelf bracket and then the other end of the shelf light housing on the notch of the shelf bracket on the opposite end. Note: On models without shelf lights, use a shelf support instead of a shelf light housing.
4. Push shelf light cords into plastic shelf cord retainer clip located on the inside of the shelf bracket.
5. Remove the cap from the appropriate female light sockets. **Important:** Grip each side of cap firmly and wiggle and pull cap straight out of socket. Do not roll cap during removal. Incorrect removal of cap may cause damage to electrical connection

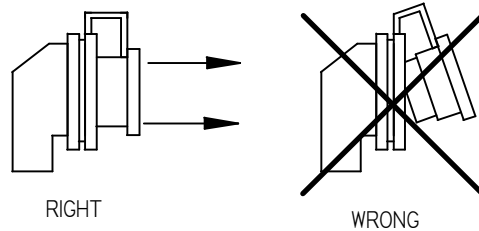

6. If the socket is not being used for a shelf light, the cap must be plugged into socket for entire light system to operate. On Models with the 5 pin shelf plug, this is necessary for the entire light system to operate. On models with the 3 pin shelf plug, this is necessary to prevent buildup and damage to the receptacle.
7. Plug in shelf light by aligning the male pins on the appropriate shelf light cord plugs with the female light sockets and push together. **IMPORTANT:** Do not roll plug during insertion.
8. Hang one end of the shelf support on to the rear notch of one shelf bracket and then on the rear notch of the shelf bracket on the opposite side.
9. Place supplied shelving onto shelf supports as outlined in the appropriate “Shelf Installation” section of this manual.
10. Removal of shelving is performed by following steps in reverse order.
11. The shelf standards are removable from case by removing the (2) shelf standard retaining screws holding them to the inside wall of case.

9.2 SOLID SHELF INSTALLATION

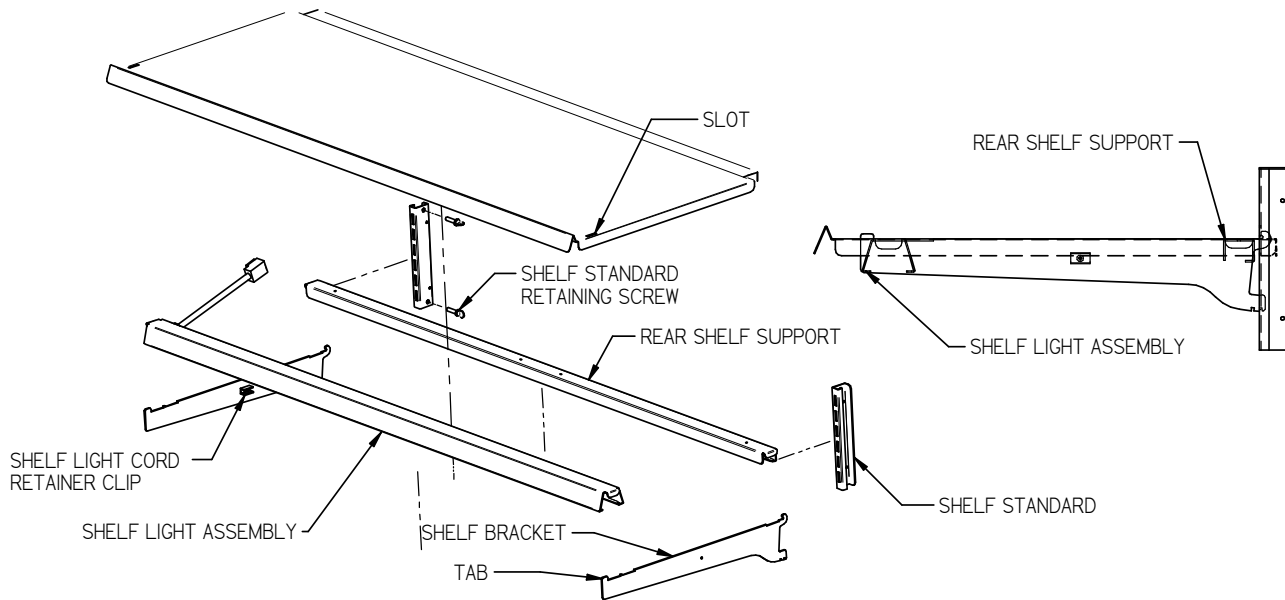

1. Install shelf brackets & shelf supports as described in Shelf Bracket & Supports Installation Section of this manual.
2. Place the front of metal shelf onto front shelf light. (On front shelf support for models without shelf lights). The tab on end of shelf bracket must go through slot in front of shelf.
3. Place the back of shelf over the back of the rear shelf support.

9.3 GLASS SHELF INSTALLATION (OPTIONAL)

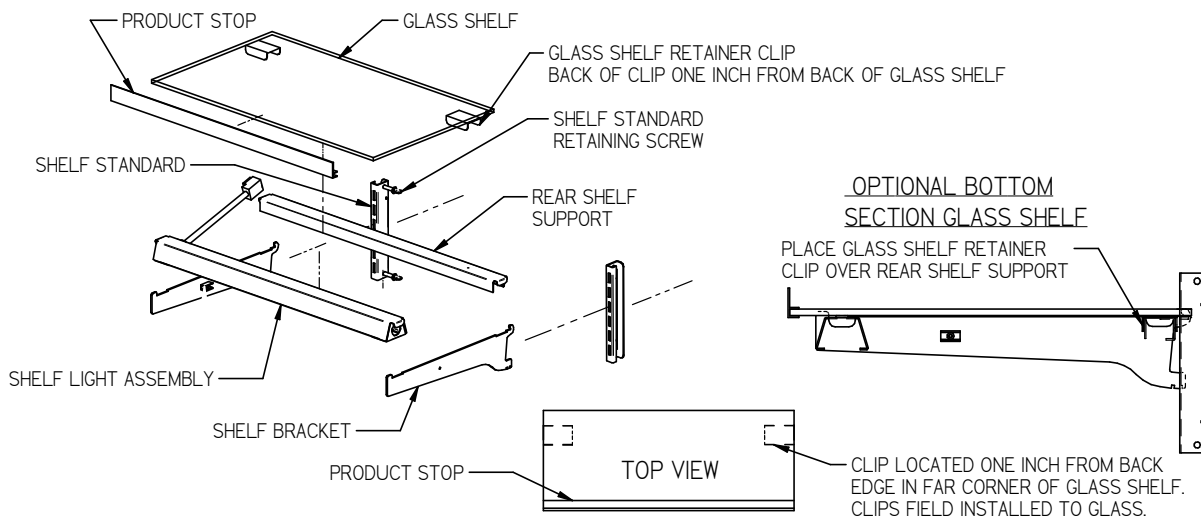

1. For first time installation attach (2) glass shelf retainer clips to each glass shelf in location shown in illustration one inch from back of glass as shown. Clean area of glass where glass shelf holder is to be located with rubbing alcohol and let air dry before installing shelf glass holder. Remove backing from tape located on flat side of glass shelf holder. Position the glass shelf holders in the (2) far corners of glass. Repeat for each glass shelf.
2. For first time installation attach (1) product stop to each glass shelf as shown in detail above. Align the product stop edge with the edge of the glass and push the "U" portion of the product stop on to glass lip across the entire front of glass.
3. Attach a clear bumper on both sides of the light housing top surface for the front of the glass to set on. This step may have already been performed at the factory for you.
4. Place front of glass shelf onto clear bumpers on front shelf light. (On front shelf support for models without shelf lights).

(10) SSRPF CASE REAR DOORS (OPTION)

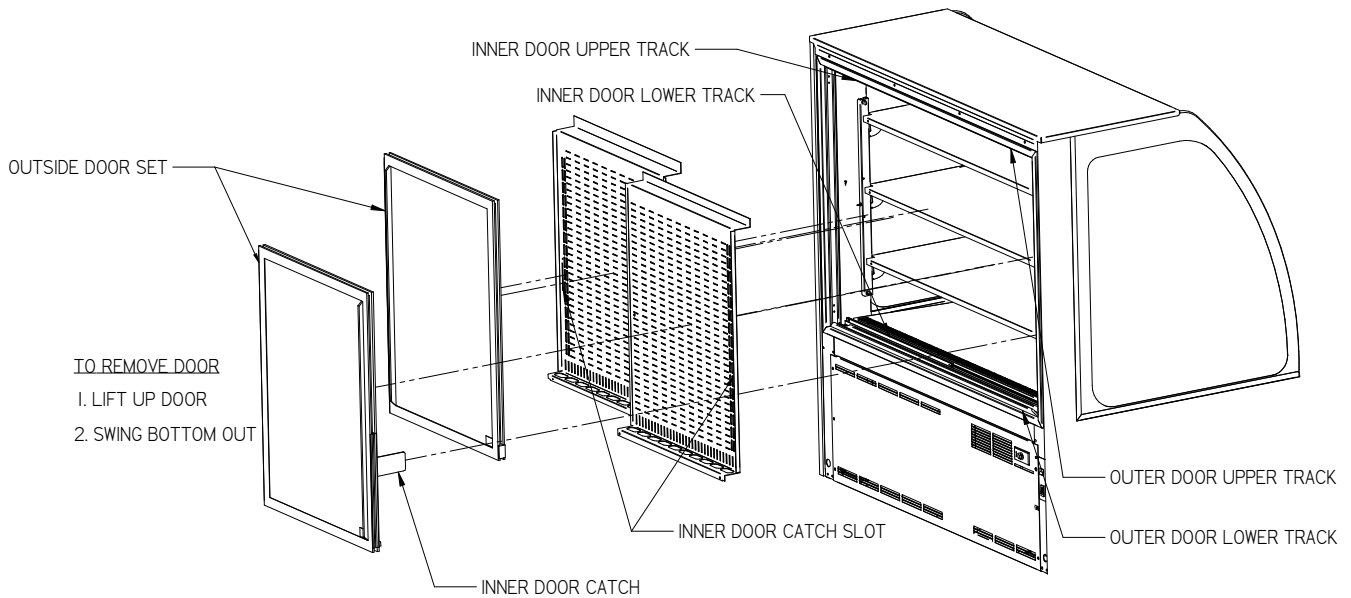

1. Start with the outer “outside door” and lift the door upward until the bottom edge of door clears the lower track and then swing the bottom of the door outward and down and out of upper track.
2. Remove the outer “inside door” using the same procedure.
3. The inner door set can then be removed using the same procedure starting with the inner “outside door” followed by the inner “inside door”.
4. Reverse this procedure for door reinstallation starting with the inner “inside door” followed by the inner “outside door”. Check that all the doors slide freely.
5. Replace the outside “inner door” and the outside “outer door”. Be sure to slide the inner door catch into the inner door catch slot for each left and right side door.

Note: All four rear doors are “not” interchangeable. Each rear door must be replaced in each doors original location.

(11) NIGHT CURTAIN OPERATION

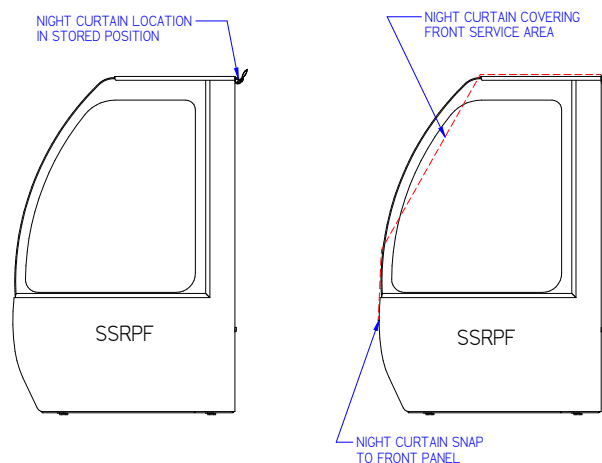

The night curtain rolls up and is stored on the back top edge of the case as shown in first view.

The curtain can be used to cover the front open display area as shown in the second view above.

OPENING SSRPF NIGHT CURTAIN:

Standing in back of the case, grab the night curtain strap and pull the rolled night curtain up and over the top and front of the case. Attach the snap located under the night curtain strap on to the snap located on the case front lower panel

CLOSING SSRPF NIGHT CURTAIN:

From front of case grab the night curtain strap and detach the snap located in the case front lower panel. Allow the night curtain to roll up over the top and back of the case. **Note:** The 59” and 77” models have (2) night curtains.

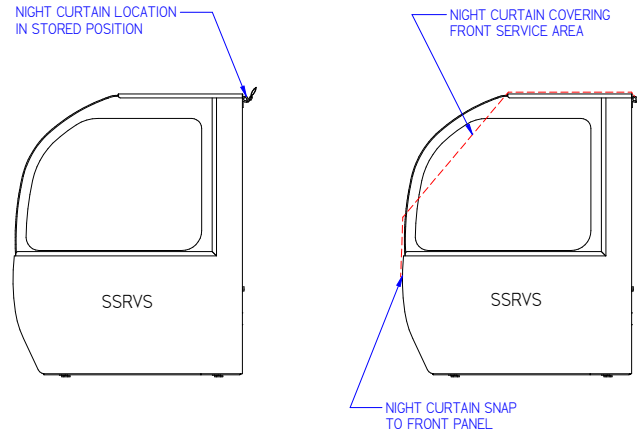

OPENING SSRVS NIGHT CURTAIN:

Standing in back of the case, grab the night curtain strap and pull the rolled night curtain up and over the top and front of the case. Attach the snap located under the night curtain strap on to the snap located on the case front lower panel

CLOSING SSRVS NIGHT CURTAIN:

From front of case grab the night curtain strap and detach the snap located in the case front lower panel. Allow the night curtain to roll up over the top and back of the case.

Note: The 59” and 77” models have (2) night curtains.

(12) SECURITY NIGHT COVER (OPTION)

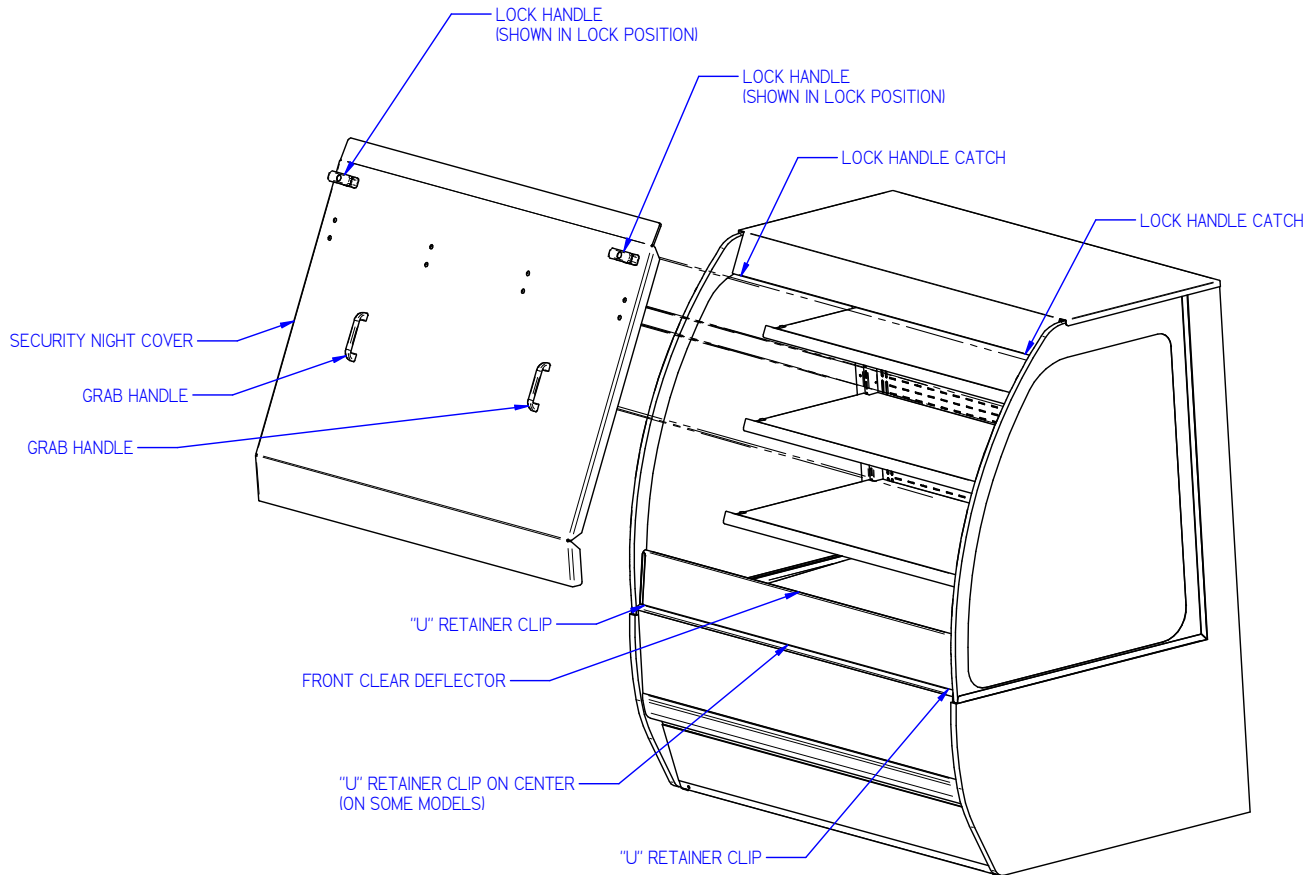

REMOVAL:

1. Unlock the lock handles and turn handles vertical to disengage from lock handle catches.
2. Grab the front grab handles and lift the cover straight up out of the case opening.

INSTALLATION:

1. Turn the lock handle so the latch handle is vertical to the top of the case.
2. Holding the grab handles place the bottom flange of the security night cover inside the "U" retainer clips located on each side of case opening behind the front clear deflector. There also may be a "U" retainer clip in the center of the case that must also engage the security night cover flange.
3. Set the top flange of the security cover down against the top glass handle.
4. Turn the lock handles so they engage the lock handle catches and use the key to lock them in place.
- 5.

IMPORTANT: Cleaning the Acrylic plastic security night cover require special care to prevent hazing of material. Lightly dust (not wipe) the surface with clean soft cloth. Then the surface can be wiped carefully with a soft, wet cloth or chamois. The cloth or chamois must be kept free of grit by frequently rinsing in clean water. Grease and oil can be removed with kerosene. Do not use window cleaners or kitchen scouring compounds. **DO NOT** use solvents such as Acetone, Benzene, Carbon Tetrachloride, and Lacquer Thinners. A spray wax such as Pledge or Maguire's polish can be applied and wiped with a clean soft cloth. The wax tends to fill in and hide small scratches.

(13) OPERATING INSTRUCTIONS

13.1 USER CONTROLS OVERVIEW

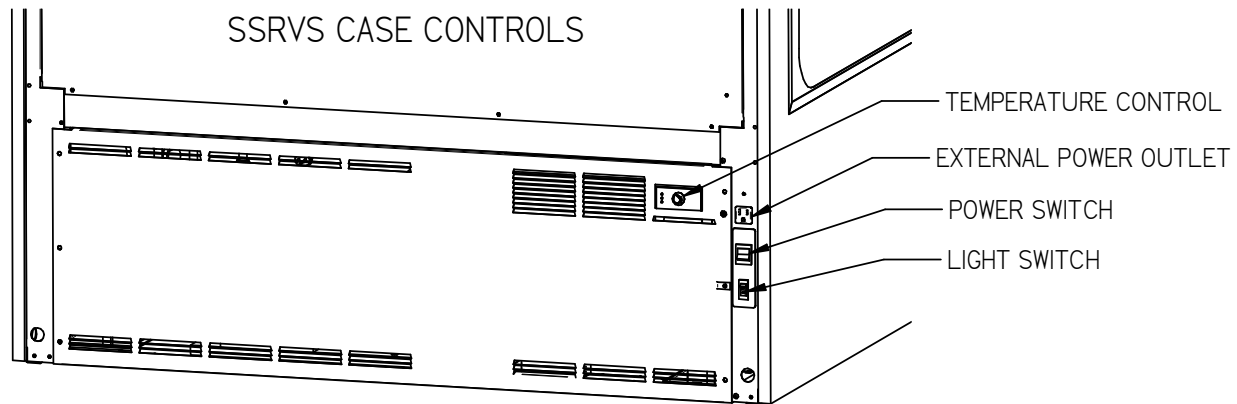
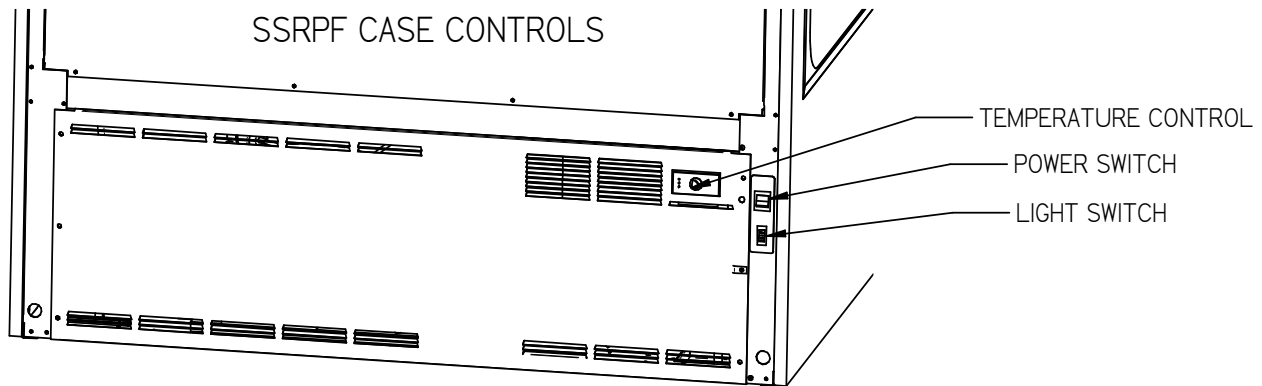

13.2 POWER SWITCH

The unit has a power switch that turns off power to parts of the unit, **Does Not Include** the condensate evaporator, the evaporator fans and the base fan. These need to be switched off at the breaker.

13.3 LIGHT SWITCH

The unit has a light switch that turns on and off the interior lights of unit.

13.4 ELECTRONIC TEMPERATURE CONTROL

Located in the rear grille of the display case, the temperature control allows the user to adjust the temperature of the display merchandiser to their needs.

13.4.1 Button and Display overview

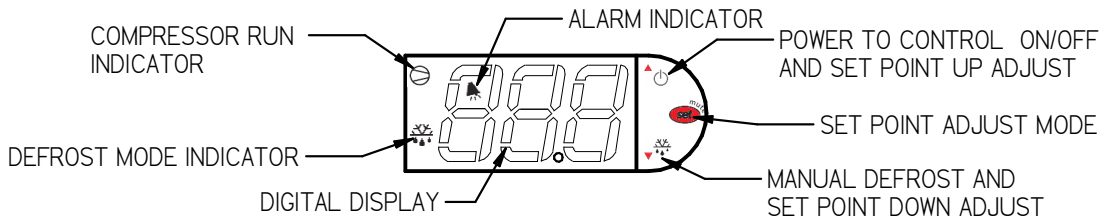

Button Overview

	Press and hold this button for three seconds to turn system on (if off) or off (if on). Also used to adjust set point when in set point adjust mode
	Press to enter set point adjust mode, confirm set point changes, and mute alarms.
	Press and hold this button for three seconds to initiate a manual defrost (and cancel defrost if initiated), also adjusts set point down when in set point adjust mode

13.4.2 Powering on control

To turn refrigeration control power on, press and hold for approx. three seconds. The display will read “On” while the button is depressed. When the control powers on, the display will read the current set point (a number “1” thru “9”). The compressor run indicator will illuminate on the display, meaning that the compressor is running. (Note: the control may already be in the on mode when shipped from factory).

To turn refrigeration control power to off, press and hold for approx. three seconds. The display will read “Off” while the button is depressed. When the control powers off the display will flash back and forth between the relative current case temperature and “Off”. The compressor run indicator will be off on the display. When refrigeration control is in the off-mode cabinet lights and evaporator fans will still operate, but the compressor will not turn on causing the case to gradually reach room temperature.





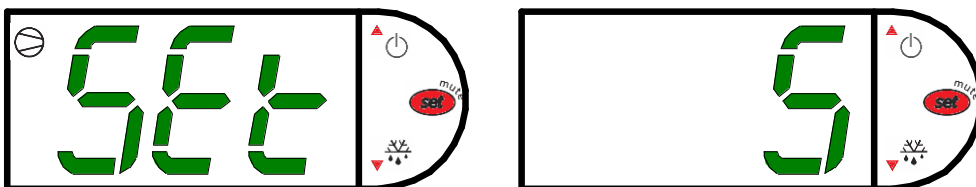

13.4.3 Adjusting the set point

The set point is what determines how cold the display case will hold food and beverage. To adjust the set point press and hold the button approx. three seconds until the display begins to flash a number. Then press the use the button to scroll number up (colder) or press the button to scroll number lower (warmer). There are nine (9) available set points numbers, the higher the number of the set point, the colder the display case will run, with setting “9” being the coldest and setting “1” being the warmest. Once you have chosen your desired setting press the button again to confirm your choice.



13.4.4 Entering Manual Defrost Mode

In order to initiate a manual, defrost press and hold the  button approx. three seconds. The control will read “dEF” while the button is being held. The defrost is initiated when the defrost mode indicator  illuminates on the display. The control display will then return to reading the case temperature. When the defrost mode indicator  turns off the defrost is complete and the compressor will turn back on illuminating the compressor run indicator .



13.4.5 Error codes

It is possible for error codes to be displayed on the control screen. In the event of a malfunction an alarm will sound and the alarm indicator  will be displayed on the display. An error code or codes will flash intermittently on the display. If there are multiple codes, the display will continuously cycle through them. The following photo shows error code “E0” as an example.



Mute: You may mute the alarm by pressing and releasing the wrench button. The red ringing bell and all error codes will still be displayed. When the fault is remedied the control will return to normal operation and will automatically clear the codes from the display.

EO = Air sensing probe - Open or shorted

E1 = Evap. coil probe - Open or shorted

Error codes may be encountered if either the controller or the display case is malfunctioning. The following is a list of error codes that may be encountered.

Table 1 - Error Codes and Resolutions

Code	Description	Cause	Resolution
E0	Temperature probe error	Probe signal is interrupted or short-circuited	Check to ensure probe wires and quick disconnect are secure in control. Check probe resistance to table below. If 0 resistance is present check wiring insulation. If infinite resistance is present check for breaks in wiring (meter will likely read overload or very high in the mega-ohm range). Ensure that probes are wired per the wiring diagram provided. Replace probe if other remedies fail, or if probe resistance deviates from “ Error! Reference source not found. ” Error! Reference source not found.
E1	Defrost probe error	See E0	
EE	Unit parameter reading error	Operating conditions	Remedy abnormal operating conditions. The control is rated to operate in a range of 14 to 122°F (-10 to 50°C) and less than 90%RH non-condensing. Replace control if problem persists.
EF	Operating parameter reading error	See EE	

13.5 ELECTRONIC CONTROL OPERATION

This unit is equipped with an electronic temperature control. The control parameters are set at the factory and cannot be manually changed in the field. The pre set control parameters are listed on the chart in the Settings Chart below.

Operation

The control uses two sensors, one located in the air stream and one located on the evaporator coil. The sensor located in the air stream is referred to as the temperature control sensor. The sensor located on the evaporator coil is referred to as the defrost probe.

The temperature control sensor is located on the plastic tub behind the evaporator coil to the left in the cold air stream. The sensor location is critical for proper operation on the unit. Do not move or relocate this sensor.

The coil sensor is strapped to the evaporator coil. This sensor location is critical for proper operation of the unit. Do not move or relocate this sensor.

The temperature control is set to cut in at 39°F (3.9°C). The Temp control cuts out at 26°F (-3.3°C) at the coldest setting “9” and 36°F (2.2°C) at the warmest setting “1”.

See “**Error! Reference source not found.**” on page **Error! Bookmark not defined.** for more details on using the control.

Defrost Cycle

The control is programmed to initiate defrost via two different methods. There are 3 programmed defrost cycles in the case which will initiate a defrost cycle every 8 hours. The unit does not have a time clock so the defrost cycles cannot be set for any specific time of day.

The unit also has an ‘On demand’ defrost feature that will initiate a defrost when the temperature differential between the evaporator temperature and the air temperature is more than 20°F (11.1°C) for 5 minutes after 30 minutes into the refrigeration cycle (e.g. if the air stream probe measures 42°F/5.6°C or greater and the defrost probe measures 20°F/-6.7°C or lower for five minutes). Once initiated the defrost cycle will terminate when evaporator coil sensor reaches 43°F (6.1°C).

If a manual defrost is required, one can be initiated by pressing and holding the down arrow for three (3) seconds. This is typically unnecessary and should only be performed if special circumstances require it.

13.6 INITIAL STARTUP

After all the checks outlined in the installation section of this manual have been made, the case is ready to be put into service. Turn on the Power at the breaker box and flip the Power Switch and Light Switch on unit to the on position. Also ensure that the control is powered on as described above in “**Error! Reference source not found.**”.

At start up from a warm unit, it is recommended that the temperature control is set to a warmer setting, such as 1. After the unit has gone through several cycles, adjust the control to a mid-range setting, then to a colder setting if necessary to maintain desired product temperature



NOTICE:

This refrigerated display case is designed to operate in a maximum environment of 75°F (23.9°C) and 55% relative humidity. Exceeding these limits will cause poor case performance and excessive sweating.

(14) REFRIGERATION OPERATION

14.1.1 Remote Models

REMOTE				
	SSRPF3652/ SSRVS3642	SSRPF5052/ SSRVS5042	SSRPF5952/ SSRVS5942	SSRPF7752/ SSRVS7742
Refrigeration R454c Charge	N/A	CHARGED IN FIELD		
Remote Low Press. Switch Cut In	N/A	50		
Remote Low Press. Switch Cut Out	N/A	15		
Remote High Press. Switch Cut Out	N/A	450 psi		
BTU Requirement @90F/20F	N/A	5400	6400	7400

E3555-1 EXCEL

The remote models are designed to use R454c refrigerant and shipped from the factory with the evaporator coil, expansion valve, sight glass, and refrigerant solenoid valve. Filter Drier must be installed in field. Electronic control runs identical to the self-contained models except the electronic control opens and closes a refrigeration solenoid valve located on the suction line instead of turning on and off a compressor. The solenoid valve closes and shuts off the refrigeration flow to the unit and initiates a pump down cycle. This will allow the remote low-pressure switch to open and shut off remote compressor.

The condensing unit and pressure controls are optionally supplied from the factory for remote location installation. The condensing unit must be mounted and wired by the installer. The high low-pressure switch must be wired in series with the compressor power supply as shown in diagram below

1. Mount condensing unit indoors as close to the remote display case as practical. The refrigeration line should be as short as possible and must not exceed 30 feet.
2. All refrigeration and/or electrical materials between the condensing unit and display case are to be supplied by installing contractor.
3. Route properly sized and designed refrigeration lines from the condensing unit to the cabinet.
4. Horizontal suction lines should be pitched downward towards the condensing unit at least 1/2" per 10' run to aid the oil drainage. A "P" trap must be installed in the suction line at the foot of every riser to insure oil return. Dry nitrogen must be used to flow through tubing while brazing refrigeration lines.
5. Suction line must be insulated the entire length with Armaflex (or equivalent). Do not run liquid line inside insulation with suction line.
6. The remote high/low-pressure control must be mounted, wired and set pressures by the installer.
7. Leak check condensing unit, cabinet, and all connecting tubing. Cabinet and condensing unit tubing should be checked to insure no leaks occurred during shipping or from rough handling.
8. Make certain all refrigeration valves are opened and evacuate system to 500 microns. Charge the system with refrigerant type specified on the data plates.

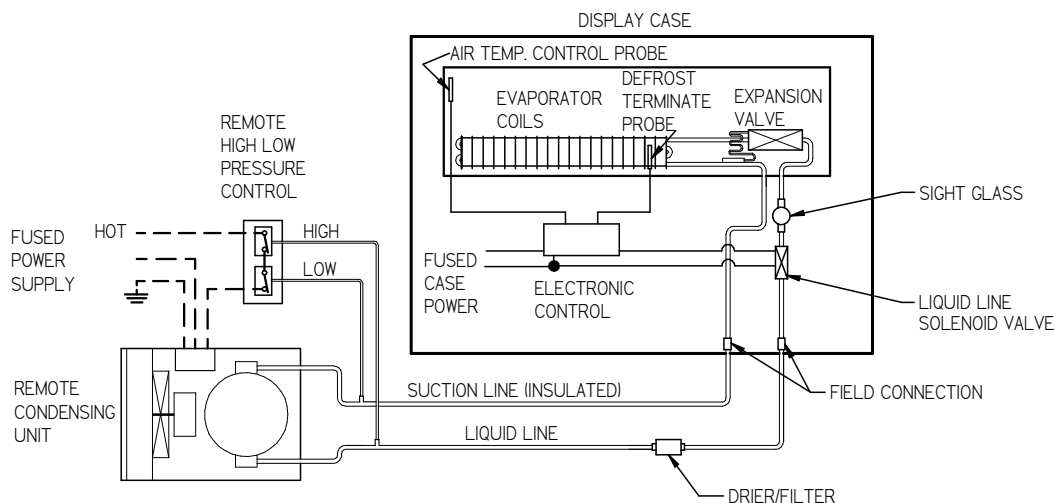

Figure 1 - Remote Refrigeration Diagram

Electronic Expansion Valve (EEV)

A traditional TXV uses springs and a temperature bulb to open and close a valve port that controls the flow of refrigerant entering the evaporator coil. An electronic expansion valve (EEV) controls the refrigerant flow much more precisely, increasing the performance and efficiency of the refrigeration system. The EEV controls the flow of Refrigerant by opening and closing the valve port based on the response to signals sent to the EEV by an electronic controller. The electronic Control bases these signals by processing information provided from a temperature sensor and pressure transducer located on the discharge side of the evaporator coil.

These sensors monitor the evaporator superheat and protects the compressor from any liquid flood back under low superheat conditions.

EEV Controller Settings

The electronic expansion valve controller also allows the use of different types of refrigerants without the need to change the expansion valve.

The controller is set from the factory to run on R454C refrigerant (code 54C) and will not need any changes to the control unless another refrigerant is used.





Note: on units with older model EEV'S, the EEV is set to code 40C.

Note: Check your State and Local regulations for approved refrigerants for your install location. Federal Industries is not liable for any alternate refrigerants used.

The control is located in the base.

Note: Never change any of the other setting other than the refrigerant type. It may also be necessary to change the superheat setting only when using a different refrigerant.



Indicator lights	
	Red light - critical alarm (system is NOT running)
	Yellow light - non-critical alarm (system running)
	Green light - compressor on
	Green blinking - compressor waiting on timer to start/stop

Changing Refrigerant

- Access the set point mode by pressing and holding the **ENTER** button until Ctl displays on the screen.
- Use the **▲** up or **▼** down arrows to advance through the available set points until rFG displays on the screen and press the **ENTER** button.
- Use the **▲** up or **▼** down arrows until the desired refrigeration displays on the screen and press and hold the **ENTER** button until rFG once again displays on the screen.
- Press the **BACK** to return to escape the settings menu.

Changing Superheat

- Access the set point mode by pressing and holding the **ENTER** button until Ctl displays on the screen.
- Use the **▲** up or **▼** down arrows to advance through the available set points until SSP displays on the screen and press the **ENTER** button.
- Use the **▲** up or **▼** down arrows to set the desired superheat displays on the screen and press and hold the **ENTER** button until SSP once again displays on the screen.

Press the **BACK** to return to escape the settings menu.

14.2 REMOTE UNITS THERE ARE SPECIAL REQUIREMENTS FOR A2L REFRIGERANTS SUCH AS R454C

Piping material, pipe routing, and installation shall include protection from physical damage in operation and service, and be in compliance with national and local codes and standards, such as ANSI/ASHRAE 15, IAPMO Uniform Mechanical Code, ICC International Mechanical Code, or CSA B52. All field joints shall be accessible for inspection prior to being covered or enclosed

The installation of pipe work shall be kept to a minimum.

Federal remote units are charged with dry nitrogen only. Joints made in the installation where any part is precharged shall be made in accordance with the following:

- a) A brazed, welded or mechanical connection shall be made before opening the valves to permit refrigerant to flow between the refrigerating system parts. A vacuum valve shall be provided to evacuate the interconnecting pipe and/or any uncharged refrigerating system part.
- b) Mechanical connectors used indoors shall comply with ISO14903 or UL 207 or CSA C22.2 No.140.3. When mechanical connectors are reused indoors, sealing parts shall be renewed. When flared joints are reused indoors, the flare part shall be refabricated.
- c) Refrigerant tubing shall be protected or enclosed to avoid damage. Flexible refrigerant connectors (such as connecting lines between the indoor and outdoor unit) that might be displaced during normal operation shall be protected against mechanical damage.

Mechanical connections shall be accessible for maintenance purposes.

Provisions shall be made for expansion and contraction of long runs of pipes. Protection devices, piping, and fittings shall be protected as far as possible against adverse environmental effects, for example, the danger of water collecting and freezing in relief pipes or the accumulation of dirt and debris.

Piping in refrigeration systems shall be designed and installed to minimize the likelihood of hydraulic shock damaging the system

Do not use steel refrigeration lines with Federal products.

Flexible pipe elements shall be protected against mechanical damage, excessive stress by torsion, or other forces, and that they should be checked for mechanical damage annually.

Precautions shall be taken to avoid excessive vibration or pulsation. Use vibration dampening tubing clamps as necessary, especially near sources of vibration.

This unit requires a minimum room area size to operate in. See table below for minimum room areas

This Chart Is For Remotes Only

Model	A _{min} [sq meters]	A _{lim} [sq ft]
SSRPF3652	10	110
SSRPF5052	10	110
SSRPF5952	10	110
SSRPF7752	14	150

After completion of field piping for split systems, the field pipework shall be pressure tested with dry nitrogen and then vacuum tested prior to refrigerant charging according to the following requirements:

- 1) The minimum test pressure for the low side of the system shall be the low side design pressure and the minimum test pressure for the high side of the system shall be the high side design pressure, unless the high side of the system cannot be isolated from the low side of the system in which case the entire system shall be pressure tested to the low side design pressure. See the unit data plate for applicable pressures.

2) The test pressure after removal of pressure source shall be maintained for at least 1 h with no decrease of pressure indicated by the test gauge, with test gauge resolution not exceeding 5 % of the test pressure.

3) During the evacuation test, after achieving a vacuum level of 250 microns or less, the refrigeration system shall be isolated from the vacuum pump, and the pressure shall not rise above 500 microns within 10 min. The vacuum pressure level shall be the lessor of 500 microns or the value required for compliance with national and local codes and standards, which may vary between residential, commercial, and industrial buildings.

Always follow local codes during installation.

Be sure that any refrigeration line running through an occupied space is protected against damage by using line set covers, sleeving, etc. As little line set as possible should be run through an occupied space. Run refrigeration line sets through building floors, ceilings, walls, or mechanical rooms as much as possible. Be sure to follow all local codes.

The maximum releasable charge may be required to comply with local codes. This must be calculated for the complete system as follows:

$$M_{rel} = \text{Maximum Releasable Charge}$$

$$M_{rel} \text{ of Federal Product} + M_{rel} \text{ of condensing unit} + M_{rel} \text{ of line set}$$

The table below shows various maximum releasable charge values for line sets.

		Liquid Line Maximum Releasable Line Charge By Length							
		1/4" (6.35mm)		3/8" (9.53)		1/2" (12.7mm)		3/4" (19.1mm)	
Line Length [ft]	Line Length [m]	lbs	kg	lbs	kg	lbs	kg	lbs	kg
10	3.0	0.6	0.3	0.8	0.4	1.1	0.5	1.6	0.7
50	15.2	1.1	0.5	2.1	1.0	3.5	1.6	5.1	2.3
100	30.5	1.8	0.8	3.8	1.7	6.5	3.0	8.7	3.9
250	76.2	3.8	1.7	8.8	4.0	15.6	7.1	21.7	9.8

		Suction Line Maximum Releasable Line Charge By Length							
		1/2" (12.7mm)		5/8" (15.9mm)		3/4" (19.1mm)		7/8" (22.2)	
Line Length [ft]	Line Length [m]	lbs	kg	lbs	kg	lbs	kg	lbs	kg
10	3.0	1.0	0.4	1.3	0.6	1.7	0.8	2.2	1.0
50	15.2	3.1	1.4	4.8	2.2	6.8	3.1	9.2	4.2
100	30.5	5.8	2.6	9.2	4.2	13.2	6.0	17.9	8.1
250	76.2	13.9	6.3	22.3	10.1	32.4	14.7	44.1	20.1

(15) REFRIGERANT DETECTION AND MITIGATION SYSTEM

REMOTES ONLY

The refrigerant detection system (RDS) shuts down the operation of the refrigerator when a leak is detected. The system is comprised of 2 or more sensors, a low voltage power supply, 1-2 safety shutoff solenoid valves, and 1-2 refrigerant check valves.

When a leak is detected by one of the sensors, the internal sensor relay opens to shut off the safety solenoid valve(s). The refrigeration check valve prevents any back flow from the rest of the external system from entering the unit that would further contribute to a leak.

The sensor is equipped with an LED status light, indicating the Refrigerant Detection System's status, as shown below:



Please note that once a leak is detected and the flow of refrigerant is stopped, the display case will stop cooling, and any temperature sensitive products must be removed from the unit.

This display case's fans are a part of the leak mitigation system and are required to remain powered on as long as there is power to the display case. In the event of a refrigerant leak, the unit's fans are required to run to reduce the concentration of flammable refrigerant in and around the unit. When replacing gas detection sensors, only replace with the original model of sensor provided by Federal.

To replace a faulty sensor, simply remove unplug the electrical quick connection and unscrew the sensor fasteners and attach the new sensor to the original sensor location in the original orientation.

After replacing installing the new sensor, power on the display case. After a few seconds, the sensor light will begin to blink green. See illustration above. The refrigeration system will be allowed to run as normal.

The sensor is capable of a long life and will monitor its condition to ensure functionality. If the sensor's self-monitoring system detects an issue it will go into a fault state and shut off the flow of refrigerant to the appliance. See above illustration for fault indication on LED.

The gas inlet exposes the sensing element of the sensor to surrounding gases. The opening in the sensor housing exposes the humidity and temperature sensors inside the sensor to the environment and makes them susceptible to pollutants such as volatile chemicals, acids, bases, cleaning and foaming agents. Exposure to those pollutants should be avoided. Cleaning products might damage the sensor or temporarily block its gas inlet, inhibiting or delaying the response to the refrigerant.

The use of solvent emitting materials near the sensor, such as PVC cement glues, may lead to nuisance trips. Solvent emitting materials can lead to high concentrations of volatile gas in the nearby environment. The gas sensor may sense these concentrations, and trigger a system mitigate response. Please note that the safety shut-off valve system is installed at the factory. No safety shut-off valves are required to be installed in the field on new equipment.

REMOTE CASES ONLY

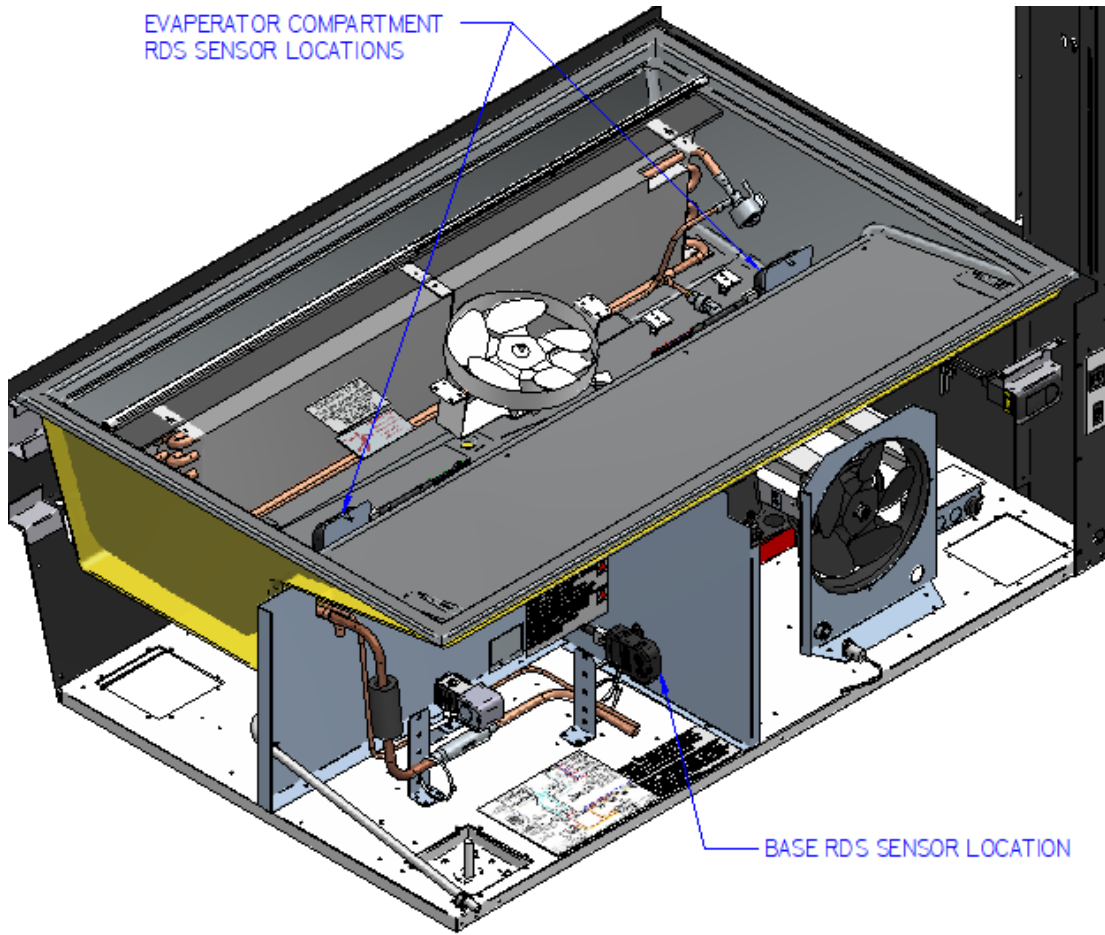

15.1 PLACING PRODUCT IN CASE

- Do not exceed weight limits shown in the table below when loading product into the display case.

Table 3 - Shelf Loading Limits

Model	Top Shelf	Middle Shelf	Bottom Shelf	Display Deck
SSRPF/VS36	80lbs (36kg)	100lbs (45kg)	120lbs (55kg)	165lbs (75kg)
SSRPF/VS50	120lbs (55kg)	140lbs (64kg)	170lbs (77kg)	240lbs (109kg)
SSRPF/VS59	140lbs (64kg)	170lbs (77kg)	210lbs (95kg)	290lbs (132kg)
SSRPF/VS77	180lbs (82kg)	230lbs (105kg)	270lbs (123kg)	390lbs (177kg)

- Determine desired shelving location before placing product in case. Product must be removed to readjust shelf location and angle.
- Do not overhang the front or rear of shelves with product. Improper clearance in front and rear of shelf will block the refrigerated air flow and will cause product loss.
- Do not block the slots along the front and rear air discharge slots. Covering these slots will block the refrigerated air flow and will cause product loss.
- The display deck is removable for cleaning and can become dislodged in shipment. To ensure proper airflow and performance of the case, make sure that the display deck is pushed completely down into the plastic evaporator tub.
- Allow refrigerated models to run for at least two hours before placing pre-chilled product into unit.
- Allow a minimum of 2" between the top of product and bottom of shelf.



NOTICE:

Case must be stocked with pre-chilled product only. Product should be at or below 40°F (4.5°C) before adding it to the display case. Use a refrigerator to pull down product that is above 40°F (4.5°C). This display case is a temperature *holding* product only. It *will not* pull down product that is above the recommended temperature.

(16) MAINTENANCE (LIGHTS)

IMPORTANT: Read this Section of this manual located on page 6 thru 10.

“REFRIGERATION WARNING & INSTALLATION-REPAIR-DECOMMISSIONING”

All refrigeration and electrical work must be performed by certified technicians.

Top/Ceiling Light Bulb Replacement, LED

- Turn power switch on rear of case to “off.”
- Disconnect light cord barrel plug from receptacle in LED by pulling barrel plug straight out.
- The LED is attached to clips mounted to the ceiling or top light housing. Disengage the LED from the clips.
- Attach the new LED to the clips on the ceiling. Be sure that the LED is centered about the clips.

Shelf Light Bulb Replacement, LED

- Turn power switch on rear of case to “off.”
- Disconnect light cord barrel plug from receptacle in LED by pulling barrel plug straight out.
- The LED is adhered to the front shelf support with double-sided tape. It may be necessary to use a razor blade to detach the LED from the top light housing. NOTE: TAKE CARE NOT TO DAMAGE THE FINISH ON THE FRONT SHELF SUPPORT.
- Remove the remaining double-sided tape from the FRONT SHELF SUPPORT.
- Apply a new layer of double sided tape to the new LED and adhere to the front shelf support. Locate new LED by centering between (2) .09 dia holes on the front shelf support.

(17) PERIODIC MAINTENANCE (CLEAN CONDENSER)

Cleaning Condenser Coil (All Self Contained Refrigerated Models)



NOTICE:

Condenser coil must be cleaned a minimum of twice per month to insure proper refrigeration performance and prevent compressor failure. In some environments, it may be necessary to clean more frequently. **FAILURE TO CLEAN CONDENSER COIL WILL VOID COMPRESSOR WARRANTY.**

It is very important that the condenser coil is cleaned twice per month to ensure proper refrigeration performance and to prevent compressor failure. Failure to clean condenser coil will void condenser warranty.

1. Disconnect power to the unit **at the breaker**.
2. Remove the rear base panel located on the back of the unit by removing the rear panel retaining screws.
3. Carefully vacuum the front surface of condenser coil. Take care not to bend coil fins with vacuum cleaner nozzle. A brush attachment works well to prevent this.

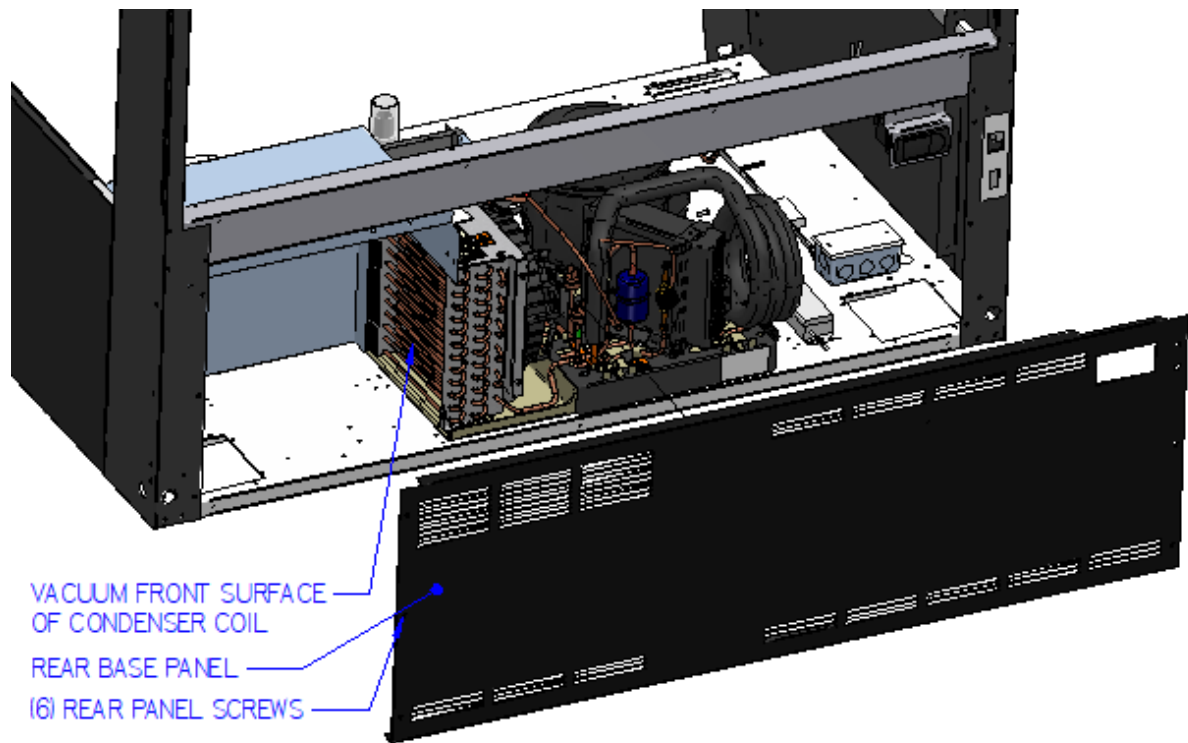





Reinstall rear panel and retaining screws.

Figure 2 - Condenser Cleaning

(18) CLEANING INSTRUCTIONS

18.1 DAILY CLEANING

The case should be cleaned thoroughly, as described in the weekly cleaning section, before it is used for the first time.

	NOTICE: Avoid splashing or soaking any electrical components with water to prevent electrical damage to the case.
	NOTICE: Shut off lights and power switches, unplug power cord and or disconnect at breaker. Allow sufficient time for the unit to reach room temperature before proceeding with cleaning. After cleaning reconnect breaker and or power cord.
	NOTICE: Remove all product from case before proceeding with cleaning procedure.
	NOTICE: Acrylic front air deflector requires special washing procedures to prevent hazing and yellowing of material.
	NOTICE: This case is not designed to be cleaned by flushing.

Note: For major spills or foreign material buildup perform the weekly cleaning instructions.

Note: Detergents are not recommended and do not use abrasive cleaners or pads to prevent scratching of surfaces.

1. Clean all foreign materials from the door opening if supplied.
 1. Wipe complete interior of both the upper & lower areas of case using a damp cloth.
 2. The remaining exterior surface should be wiped down using any ammoniated cleaners or soapy warm water.
 3. IMPORTANT: Cleaning the Acrylic plastic front deflector, front lift-up doors, and plastic inner doors require special care to prevent hazing and yellowing of material. Lightly dust (not wipe) surface with clean soft cloth. Then the surface can be wiped carefully with a soft, wet cloth or chamois. The cloth or chamois must be kept free of grit by frequently rinsing in clean water. Grease and oil can be removed with kerosene. Do not use window cleaners or kitchen scouring compounds. DO NOT use solvents such as Acetone, Benzene, Carbon Tetrachloride, and Lacquer Thinners. A spray wax such as Pledge or Maguire's polish can be applied and wiped with a clean soft cloth. The wax tends to fill in and hide small scratches.

18.2 WEEKLY CLEANING

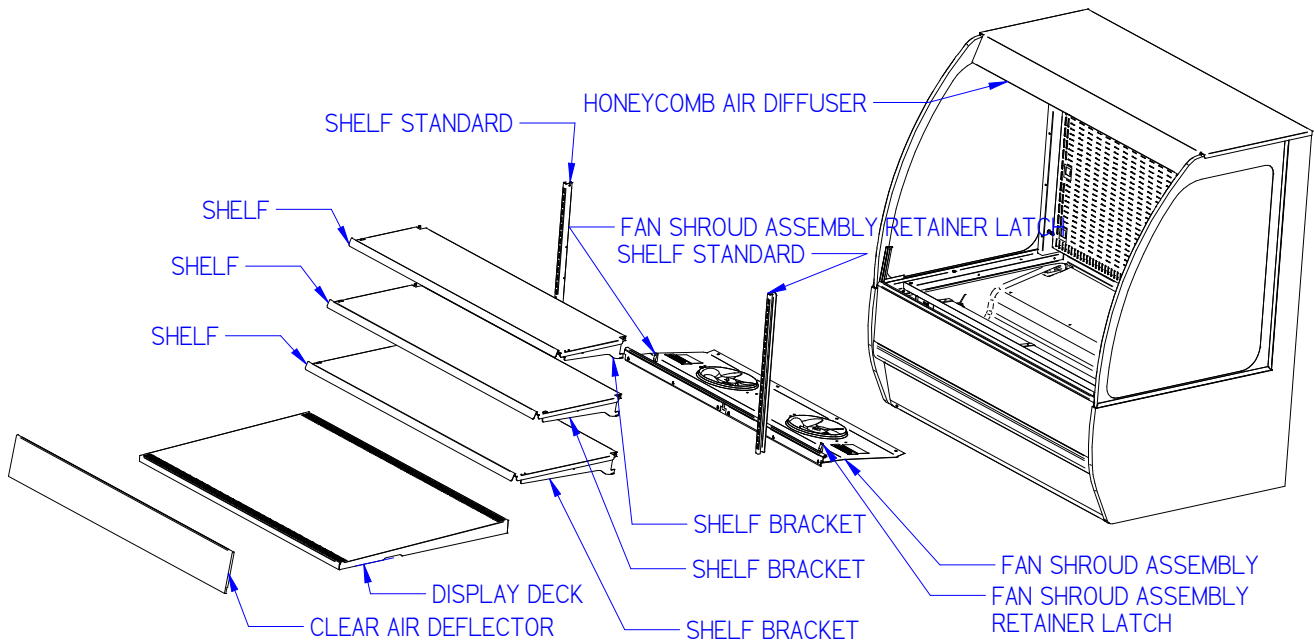

This procedure is recommended on a weekly basis. It may need to be performed more often if necessary to maintain a clean, sanitary case. The case should be cleaned to this procedure before using the first time.

	<p>NOTICE: Avoid splashing or soaking any electrical components with water to prevent electrical damage to the case.</p>
	<p>NOTICE: Shut off lights and power switches, unplug power cord and or disconnect at breaker. Allow sufficient time for the unit to reach room temperature before proceeding with cleaning. After cleaning reconnect breaker and or power cord.</p>
	<p>NOTICE: Remove all product from case before proceeding with cleaning procedure.</p>
	<p>NOTICE: This case is not designed to be cleaned by flushing.</p>

1. If supplied with rear cutting board Remove food pan catch tray by lifting it out of top of case. Clean all foreign material from around and under the food pan catch tray. Clean food pan catch tray using warm soapy water and a brush.
2. If supplied with Rear Door Option, remove both inner & outer rear doors as described in the “Door Removal” section of this manual.
3. Clean all foreign material from inner and outer rear door tracks and clean both sides of the doors using warm soapy water and a brush. Apply a light film of lubricant such as PAM to door tracks to make the doors operate smoother.
4. Remove interior shelving from unit as described in the “Shelving Installation and Removal” section of this manual. Remove both shelf standards from interior of case by removing the (2) thumbscrew from top and bottom of each standard.

5. Clean all shelves, shelf supports, shelf light housings, shelf brackets, shelf standards using warm soapy water and a brush. Rinse thoroughly and allow to dry.
6. Lift the display deck(s) up and out of evaporator tub.
7. Remove the fan shroud assembly by lifting (2) black tabs up on fan shroud assembly retainer latch at each end of the front of the fan shroud and removing the thumb screws from along the rear lip of the fan shroud. Lift the fan shroud assembly and reach in and unplug the evaporator fan motor cord(s). Lift fan shroud assembly out of tub.
8. Clean the display deck(s) using warm soapy water and a brush. Rinse thoroughly and allow to dry. Wipe off fan shroud assembly (do not rinse or submerge fan motors).
9. Clean the entire interior of the case using warm soapy water. Flush foreign material from drain area. Wipe off all soapy water with a damp cloth and allow to dry. (DO NOT use solvents such as Acetone, Benzene, Carbon Tetrachloride, and Lacquer Thinners)
10. Remove the honeycomb air diffuser(s) from upper air duct track. Loosen thumb screws on Retainer located behind diffuser. Retainer will drop down allowing diffuser to be pulled out of case.

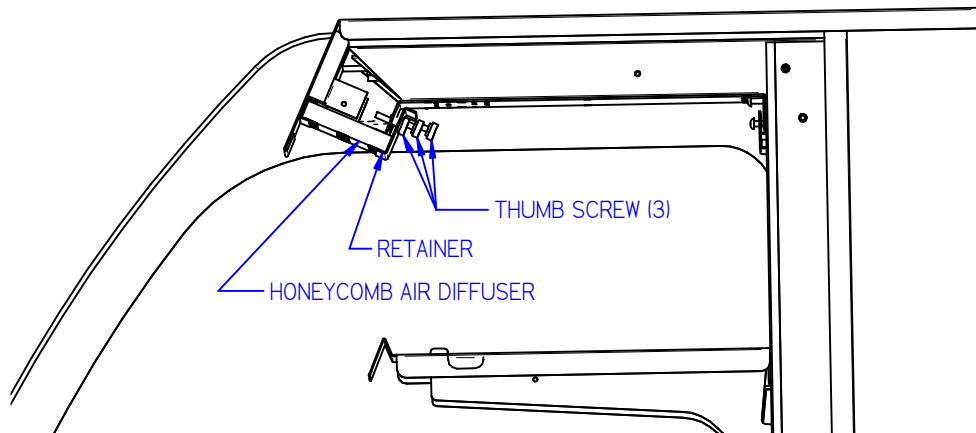

11. Clean honey comb air diffuser with warm soapy water and a brush. Rinse thoroughly and allow to dry.
12. Remove the clear plastic front air deflector by lifting it up and out of case.

IMPORTANT: Cleaning the Acrylic plastic front air deflector require special care to prevent hazing and yellowing of material. Lightly dust (not wipe) the surface with a clean soft cloth. Then the surface can be wiped carefully with a soft, wet cloth or chamois. The cloth or chamois must be kept free of grit by frequently rinsing in clean water. Grease and oil can be removed with kerosene. Do not use window cleaners or kitchen scouring compounds. DO NOT use solvents such as Acetone, Benzene, Carbon Tetrachloride, and Lacquer Thinners. A spray wax such as Pledge or Maguire's polish can be applied and wiped with a clean soft cloth. The wax tends to fill in and hide small scratches.

13. Reassemble all components in reverse order.

NOTE: Depending on the amount of usage and spillage of foreign material, some fasteners may have to be removed and parts disassembled to allow proper cleaning of the unit.

18.3 WEEKLY EXTERIOR CLEANING

1. Clean the front and end glass using any common window cleaner.
2. The exterior surfaces should be wiped down using any ammoniated cleansers or warm soapy water.

(19) SALE & DISPOSAL

IMPORTANT: Read this Section of this manual located on page 5.

“REFRIGERATION WARNING & INSTALLATION-REPAIR-DECOMMISSIONING”

All refrigeration and electrical work must be performed by certified technicians.

19.1 OWNER RESPONSIBILITY

If you sell or give away your Federal Industries case you must make sure that all safety labels and the Installation-Service Manual are included with it. If you need replacement labels or manuals, Federal Industries will provide them free of charge. Contact the customer service department at Federal Industries at (800) 3564206.

The customer service department at Federal Industries should be contacted at the time of sale or disposal of your case so records may be kept of its new location.

If you sell or give away your Federal Industries case and you evacuate the refrigerant charge before shipment. Federal Industries recommends that the charge be evacuated into a recovery system to prevent the possibility of HFO's from being released into the atmosphere.

(20) SERVICE INFORMATION

CAUTION
RISK OF ELECTRIC SHOCK

DISCONNECT POWER
BEFORE SERVICING UNIT

**Before any service work is performed
on the case, make sure all power is
disconnected to the case.**

To find a service company in your area, please visit our website at www.federalindustries.com. There you can also find self-service tools to help you get the answers you need faster!

For Warranty Service Requests & ALL Technical Support please contact:

- **Phone:** (800) 356-4206 and choose the Tech Support/Warranty Option
- **Email:** Service@federalind.com

For Warranty Compressors please contact the Parts Department:

- **Phone:** (800) 356-4206 and choose the Warranty Parts Option
- **Email:** Parts@Federalind.com



Federal Industries has partnered with Parts Town for ALL Non-Warranty Part Identification, Pricing, Lead Times, Orders & Freight Quotes. Please contact Parts Town directly if you need parts:

- **Website:** PartsTown.com
- **Email:** CustomerService@PartsTown.com
- **Phone:** 833-809-8188

20.1 SPECIAL SERVICE INSTRUCTIONS

IMPORTANT: Read this Section of this manual located on page 6 THRU 10
“REFRIGERATION WARNING & INSTALLATION-REPAIR-DECOMMISSIONING”
All refrigeration and electrical work must be performed by certified technicians.

There are rare occasions when the refrigerant charge must be evacuated from a case in order to perform service work. In those situations, Federal Industries recommends that the refrigerant charge be evacuated into a recovery system to prevent the possibility of hydrofluoro olefin (HFO's) from being released into the atmosphere.

If moisture or liquid is observed around or under a Federal Industries case, an immediate investigation should be made by qualified personnel to determine the source of the moisture or liquid. The investigation made should determine if the case is malfunctioning or if there is a simple housekeeping problem.

Moisture or liquid around or under a case is a potential slip/fall hazard for persons walking by or working in the general area of the case. Any case malfunction or housekeeping problem that creates a slip/fall hazard around or under a case should be corrected immediately.

20.2 PRE-SERVICE CHECKLIST

You may avoid the cost and inconvenience of an unnecessary service call by first reviewing this checklist of frequently encountered situations that can cause unsatisfactory case performance.



CAUTION:
Before servicing case, turn off power at the main breaker of fuse box.

Case does not operate

- Check for disconnected power supply.
- Check for tripped breaker or blown fuse.
- Check that power switch is on.

Lights do not operate

- Check that light switch is on.
- Shelf light: Check that shelf light cords are tight in the sockets and LEDs.
- Shelf light: Ensure all open sockets are filled with either shelf light cord plugs or dummy caps attached to socket.

Case temperature too warm (product is exceeding 41°F)

- Check that the cold air inlet and outlet slots are not blocked.
- If supplied with rear door option be sure that the rear doors are closed and tightly sealed
- Check for blocked or dirty condenser coil fins and clean them (see “0 Cleaning Condenser Coil (All Self Contained Refrigerated Models))

NOTICE: **Condenser coil must be cleaned a minimum of twice per month to insure proper refrigeration performance and prevent compressor failure. In some environments, it may be necessary to clean more frequently. FAILURE TO CLEAN CONDENSER COIL WILL VOID COMPRESSOR WARRANTY.**

- Check that there is no paper or foreign material blocking the evaporator, and if so remove it.
- If the evaporator coil is blocked due to excessive frost, activate manual defrost mode on the electronic control.
- Check that the case is given the proper clearance behind the rear grille (see section 9 “installation)

20.3 SELF CONTAINED WIRING DIAGRAM

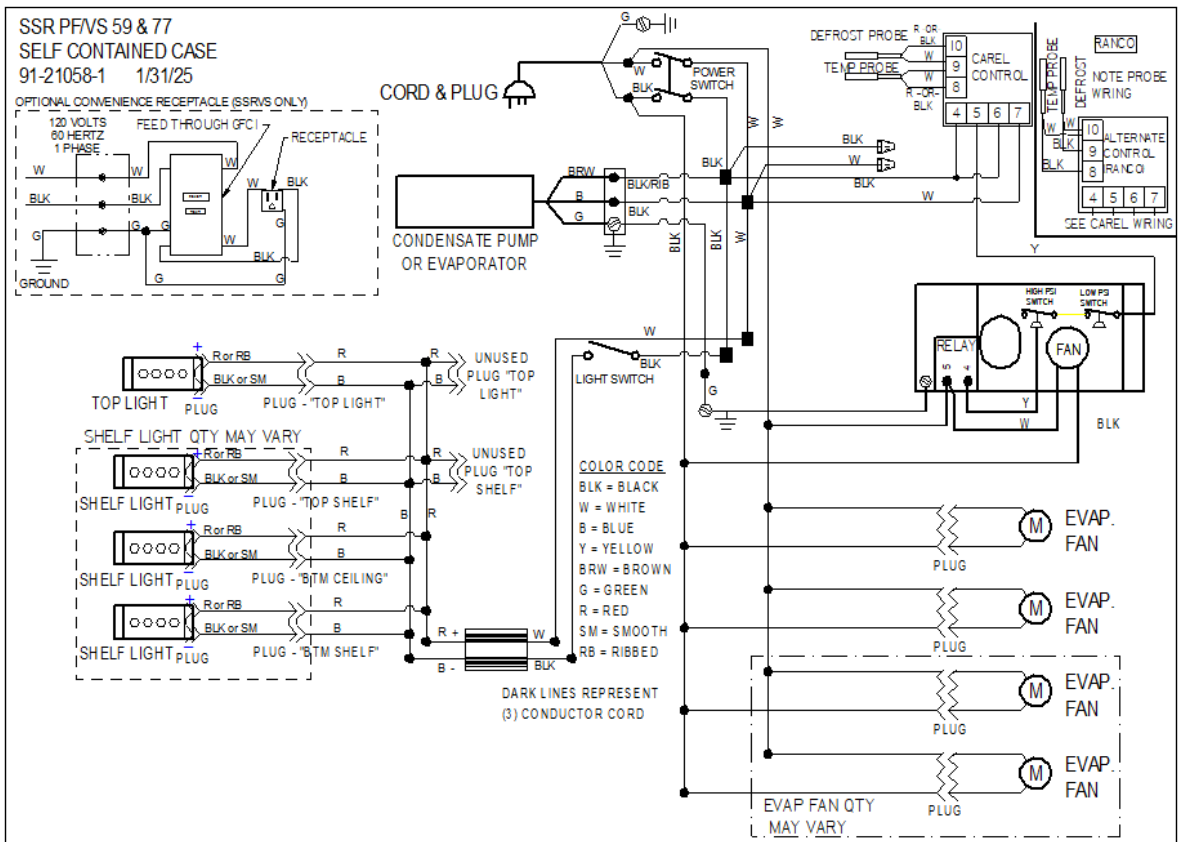
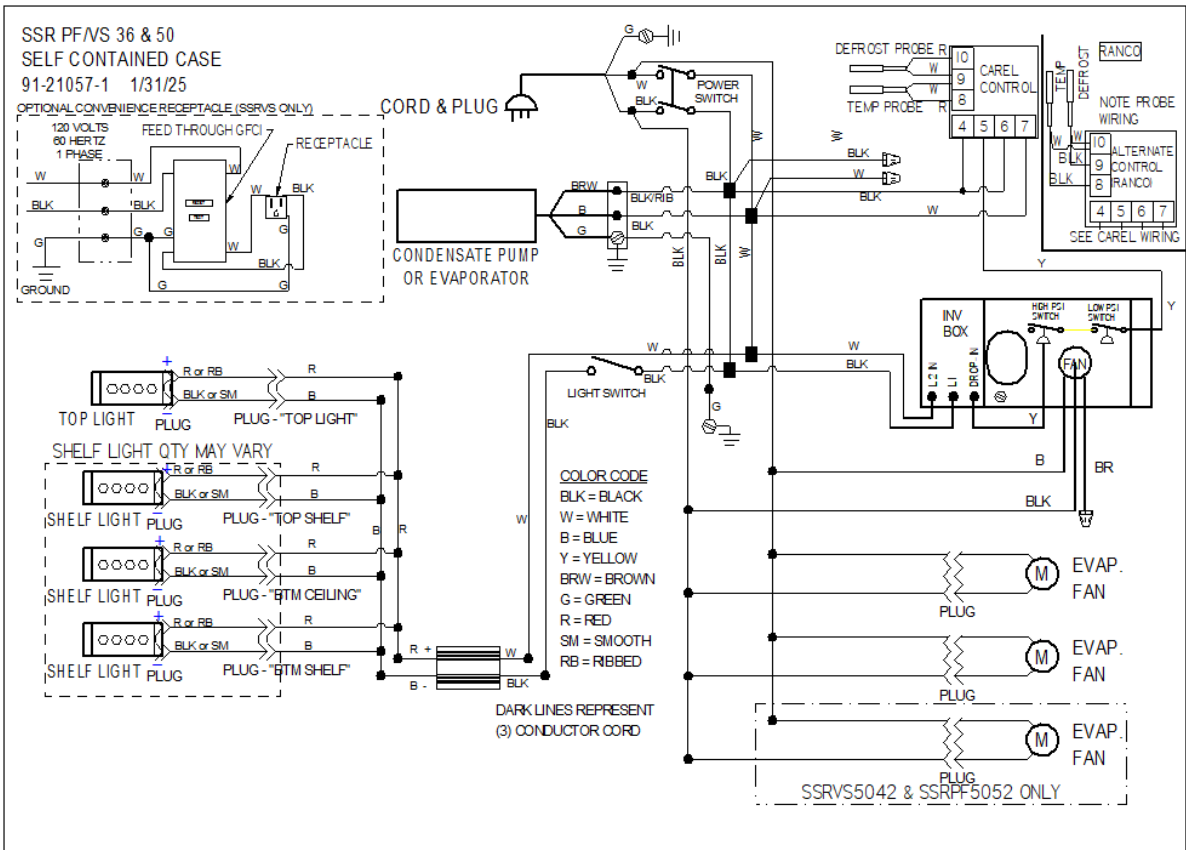

20.4 REMOTE WIRING DIAGRAM

SSR ALL MODELS
REMOTE
91-21061-10 2/10/26

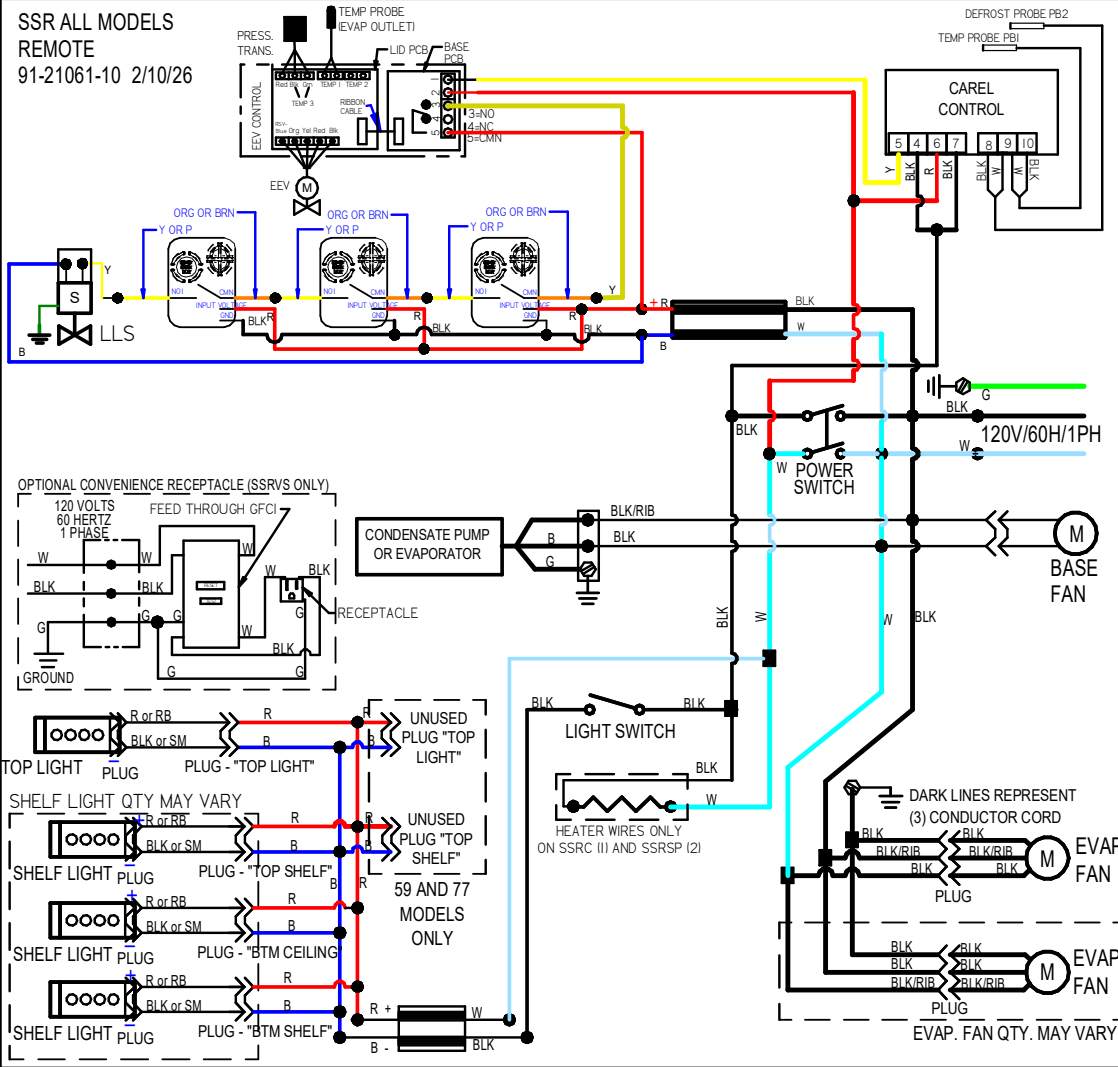

COLOR CODE

BLK = BLACK	W = WHITE
B = BLUE	Y = YELLOW
BRN = BROWN	G = GREEN
R = RED	SM = SMOOTH
RB = RIBBED	P = PURPLE
ORG = ORANGE	

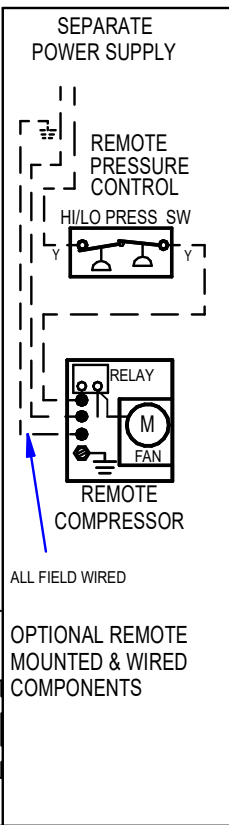

(21) REPLACEMENT PARTS

REFRIGERATION	SSRPF3652/ SSRVS3642/	SSRPF5052/ SSRVS5042/	SSRPF5952/ SSRVS5942/	SSRPF7752/ SSRVS7742/
Compressor (Self Contained)	N/A	N/A	N/A	N/A
Condensing Unit (Self Contained)	30-21754	30-21754	30-21762	30-21762
Evaporator Coil (Self Contained)	33-21706	33-21707	33-21708	33-21709
TXV (Self Contained)	32-21751	32-21750	32-21749	32-21749
Evaporator Coil (Remote)	N/A	30-13357	33-13358	33-13359
EEV (Remote)	N/A		32-21228	
Check Valve (Remote)	N/A		32-21916-4	
RDS Sensor (Remote)	N/A		32-21917	
RDS Sensor Wire Harness (Remote)	N/A		43-21921-4	
Power Supply 24V (Remote)	N/A		39-20555	
Evaporator Fan Motor (52,42 Self Contained)	41-21572-18		41-21572-16	
Evaporator Fan Motor (Remote)	N/A		41-17981	
Evaporator Fan Blade (Remote)	N/A	72-17355	72-17355	72-19270
Base Fan Assembly (Remote)	N/A		41-21237-20	
Latch Evaporator Housing to Coil	66-13640		66-13640	
Temperature Control (52,42)	32-19864-6		32-19864-6	
Temperature Probe	32-19866 (2)		32-19866 (2)	
Temperature Probe, EEV (Remote)	N/A		32-21224	
Pressure Transducer, EEV (Remote)	N/A		32-21225	
Solenoid Remote Refrigeration (Remote)	N/A		32-21915-3	
Solenoid Valve Coil (Remote)	N/A		32-21915-C24	
Condensate Pan (52,42 Self Contained)	SA5302-1		SA5302-2	
Condensate Pan Heater (Self Contained)	40-19331		40-19392	
Condensate Pump (Remote)	N/A		47-18980 230V	
Thermometer	32-13662		32-13662	
EEV Control (Remote)	N/A		32-21223	

LIGHTING	SSRPF3652/ SSRVS3642	SSRPF5052/ SSRVS5042	SSRPF5952/ SSRVS5942	SSRPF7752/ SSRVS7742
Light Switch	41-11066	41-11066	41-11066	41-11066
Power Switch	41-18186	41-18186	41-18186	41-18186
LED Power Supply	39-20986	39-20986	39-20986	39-20986
LED Ceiling Light Strip	42-20871-30C35	42-20871-42C35	42-20871-54C35	42-20871-72C35
LED Shelf Light Strip	42-20871-30C35	42-20871-42C35	42-20871-54C35	42-20871-72C35
LED (15 Inch) Shelf Light Cord	43-20862-2B	43-20862-2B	43-20862-2B	43-20862-2B
LED (18 Inch) Shelf Light Cord	43-20862-3B	43-20862-3B	43-20862-3B	43-20862-3B
LED (21 Inch) Shelf Light Cord	43-20862-4B	43-20862-4B	43-20862-4B	43-20862-4B
Power Cord (Optional)	43-30818	43-17839	43-19090	43-19090

Rear Doors Thermoseal (Optional)				
DoorTrack Frame	57-21538-5	57-21538-6	57-21538-7	57-21538-8
Door, Rear Outer Solid (Black)	53-21539-5	53-21539-6	53-21539-7	53-21539-8
Door, Rear Inner Solid (Black)	53-21540-5	53-21540-6	53-21540-7	53-21540-8
Inside Track, Door Bottom (Optional)	M16519-1	M16519-2	M16519-3	M16519-4
Inside Track, Door Top (Optional)	M19453-1	M19453-2	M19453-3	M19453-4
Inside Door, Left Slotted Blk. (Option.)	SA5409-1	SA5409-2	SA5409-3	SA5409-4
Inside Door, Right Slotted Blk. (Option.)	SA5410-1	SA5410-2	SA5410-3	SA5410-4
Door Catch, Outside (Optional)	M17196-1	M17196-1	M17196-1	M17196-1
Door Catch, Inside (Optional)	M17196-2	M17196-2	M17196-2	M17196-2
Rear Doors Thermoseal (Optional)				
DoorTrack Frame	57-21538-9	57-21538-10	57-21538-11	57-21538-12
Door, Rear Outer Solid (Black)	53-21539-9	53-21539-10	53-21539-11	53-21539-12
Door, Rear Inner Solid (Black)	53-21540-9	53-21540-10	53-21540-11	53-21540-12
Inside Track, Door Bottom (Optional)	M16519-1	M16519-2	M16519-3	M16519-4
Inside Track, Door Top (Optional)	M19453-1	M19453-2	M19453-3	M19453-4
Inside Door, Left Slotted Blk. (Option.)	SA5432-1	SA5432-2	SA5432-3	SA5432-4
Inside Door, Right Slotted Blk. (Option.)	SA5433-1	SA5433-2	SA5433-3	SA5433-4
Door Catch, Outside (Optional)	M17196-1	M17196-1	M17196-1	M17196-1
Door Catch, Inside (Optional)	M17196-2	M17196-2	M17196-2	M17196-2
Rear Doors Thermoseal (Optional)				
DoorTrack Frame	57-21538-13	57-21538-14	57-21538-15	57-21538-16
Door, Rear Outer Solid (Black)	53-21539-13	53-21539-14	53-21539-15	53-21539-16
Door, Rear Inner Solid (Black)	53-21540-13	53-21540-14	53-21540-15	53-21540-16
Inside Track, Door Bottom (Optional)	M16519-1	M16519-2	M16519-3	M16519-4
Inside Track, Door Top (Optional)	M19453-1	M19453-2	M19453-3	M19453-4
Inside Door, Left Slotted Blk. (Option.)	SA5432-17	SA5432-18	SA5432-19	SA5432-20
Inside Door, Right Slotted Blk. (Option.)	SA5433-17	SA5433-18	SA5433-19	SA5433-20
Door Catch, Outside (Optional)	M17196-1	M17196-1	M17196-1	M17196-1
Door Catch, Inside (Optional)	M17196-2	M17196-2	M17196-2	M17196-2

MISCELLANEOUS	SSRPF3652 SSRVS3642	SSRPF5052 SSRVS5042	SSRPF5952 SSRVS5942	
Air Deflector Front Clear	15-19827-1	15-19827-2	15-19827-3	
Security Night Cover Panel SSRPF(Optional)	M19299-1	M19299-2	M19299-3	
Security Night Cover Panel SSRVS42(Optional)	M19367-1	M19367-2	M19367-3	M19367-4
Security Night Cover Latch (Optional)	66-11727	66-11727	66-11727	66-11727

California Residents Only.

⚠ WARNING

This product can expose you to chemicals including chromium which is known to the State of California to cause cancer and birth defects or other reproductive harm. For more information go to www.P65Warnings.ca.gov

