



The Signature of Quality®

INSTALLATION & OPERATIONS INSTRUCTIONS
ITR & ITRSS: Self-Contained & Remote Refrigerated Models
ITD, ITDSS & ITDSSF: Non-Refrigerated Displays



KEEP THIS MANUAL FOR FUTURE REFERENCE

Engineering and technical data are subject to change without notice.

FEDERAL INDUSTRIES
Toll Free 1(800) 356-4206

215 FEDERAL AVE
WI Phone (608) 424-3331

Belleville, WI 53508
Fax: (608) 424-3234

CONTENTS

INTRODUCTION.....	4
<u>Registration and Serial Number</u>	4
WARNING LABELS & SAFETY INSTRUCTIONS.....	5
GENERAL ELECTRICAL & GROUNDING	6-8
<u>Refrigerated Permanent Connected</u>	6,7
Refrigerated Floor Models	7
Refrigerated Counter Models	7
<u>Refrigerated Cord Connected (Option)</u>	7
<u>Non-Refrigerated Cord Connected.....</u>	8
REFRIGERATION.....	9-11
<u>Self-Contained Models.....</u>	9
Self-Contained Refrigeration Operation.....	9
<u>Remote Models</u>	9
Remote Refrigeration Operation	9
Remote Refrigeration Instruction.....	10
<u>Condensate Evaporator pan and Pump.....</u>	11
Condensate Evaporator	11
Condensate Pump	11
<u>Electronic Expansion Valve (EEV) After 12/1/19.....</u>	12
EEV Controller Settings.....	12
BASE COMPONENT LAYOUT	13-19
<u>Refrigerated Self Contained Models</u>	13-16
<u>Refrigerated Remote Models.....</u>	17-18
<u>Non-Refrigerated Models.....</u>	19
INSTALLATION INSTRUCTIONS, FLOOR MODELS.....	20
<u>Inspection for Shipping Damage</u>	20
<u>Locating the Display Case.....</u>	20
<u>Removing Case from Shipping Skid.....</u>	20
<u>Additional Parts.....</u>	20
<u>Cleaning</u>	20
INSTALLATION INSTRUCTIONS COUNTER MODELS.....	21-27
<u>Inspection for Shipping Damage</u>	21
<u>Locating the Display Case.....</u>	21
<u>Removing Case from Shipping Skid.....</u>	21
<u>Additional Parts.....</u>	21
<u>Cleaning</u>	21
<u>ITD, ITDSS & ITDSSF Non-Refrigerated Models Cabinet Mounting.....</u>	22
Cabinet Preparation	22
<u>ITR Refrigerated Models Cabinet Mounting</u>	23
Cabinet Preparation	23
Cabinet Cut Out.....	23
Case Install	24
Counter Air Duct & Grills.....	25
<u>JOINING CASES, NO END GLASS</u>	26
<u>JOINING FLOOR MODEL BASES, NO END PANELS.....</u>	27
<u>JOINING CASES, SINGLE END GLASS.....</u>	28
<u>JOINING FLOOR MODEL BASES, SINGLE END PANELS</u>	29
COMPARTMENT PANEL REMOVAL	30-32
<u>Refrigerated Base Models Back Panel</u>	30
<u>Refrigerated & Non-Refrigerated Base Models Back Panel</u>	30
<u>Refrigerated Counter Models Front and Back Panels</u>	31
<u>Non-Refrigerated Models Top Cover.....</u>	32
END PANEL INSTALLATION & REMOVAL	33

SHELVING INSTALLATION & REMOVAL 34-38

- Shelf Brackets & Supports 34-36
- LED Light Plug Connection..... 36
- Glass Shelves 37
- Horizontal Dual Zone Shelf Divider 38

FRONT AND REAR DOORS REMOVAL 39-40

- ITR, ITD, ITDSS & ITDSSF Rear Doors 39
- ITRSS Rear Inner and Outer Doors..... 40

SECURITY NIGHT COVER (OPTION) 41

OPERATING INSTRUCTIONS 42-47

- Power Switch..... 42
- Light Switch 42
- Temperature Control..... 42-46
 - Button and Display Overview 43
 - Powering on Control 43
 - Adjusting the Set Point..... 44
 - Entering Manual Defrost Mode..... 44
 - Error Codes 44-45
 - Electronic Control Operation 45-46
 - Control Parameters 46
- Initial Startup..... 47
- Placing Product in Case..... 47

MAINTENANCE 48-49

- Cleaning Condenser Coil..... 48
- Top LED Strip Replacement 49
- Shelf LED Replacement..... 49

CLEANING INSTRUCTIONS 50-54

- Daily Cleaning..... 50
- Weekly Cleaning ITR, ITD, ITDSS & ITDSSF..... 51-52
- Weekly Cleaning ITRSS 53-54
- Weekly Exterior Cleaning 54

SERVICE 55-56

- Service Information..... 55
- Pre-Service Checklist 56

SALE & DISPOSAL 56

- Owner Responsibility..... 56

WIRING DIAGRAMS..... 57-60

REPLACEMENT PARTS..... 61-63

INTRODUCTION

Thank you for purchasing a Federal Industries display case. This manual contains important instructions for installing and servicing the Refrigerated Self-Service Merchandisers. A repair parts list and wiring diagram are also included in the manual. Read all of these documents carefully before installing or servicing your case.



NOTICE

Read this manual before installing your case. Keep this manual and refer to it before doing any service on the equipment. Failure to do so could result in personal injury or damage to the case.



NOTICE

Installation and service of the electrical components in the case must be performed by a licensed electrician.

The portions of this manual covering components contain technical instructions intended only for persons qualified to perform electrical work.



DANGER

Improper or faulty hookup of electrical components in the case can result in severe injury or death.

All electrical wiring hookups must be done in accordance with all applicable local, regional, or national standards.

REGISTRATION & SERIAL NUMBER

It's important to keep a record of the model and serial number of your merchandiser for warranty and part identification. Please write them here for your quick reference.

Register your product online! Visit our website at www.federalindustries.com and register your product today.

Case Model _____ Serial Number _____

We're here to provide you with the best possible experience with your new product, however, we cannot cover everything about your merchandiser in this manual, so if you have any additional questions or issues, please see the SERVICE INFORMATION PAGE to find who you should contact.

WARNING LABELS & SAFETY INSTRUCTIONS



This is the safety-alert symbol. When you see this symbol on your case or in the manual, be alert to the potential for personal injury or damage to your equipment.

Be sure you understand all safety messages and always follow recommended precautions and safe operating procedures.



NOTICE TO EMPLOYERS

You must make sure that everyone who installs, uses, or services your case is thoroughly familiar with all safety information and procedures.

Important safety information is presented in this section and throughout the manual. The following signal words are used in the warning and safety messages:

DANGER: Severe injury or death will occur if you ignore the message.

WARNING: Severe injury or death can occur if you ignore the message.

CAUTION: Minor injury or damage to your case can occur if you ignore the message.

NOTICE: This is important installation, operation, or service information. If you ignore the message, you may damage your case.

The warning and safety labels shown throughout this manual are placed on your Federal Industries case at the factory. Follow all warning label instructions. If any warning or safety labels become lost or damaged, call our customer service department at 1(800) 356-4206 for replacements.

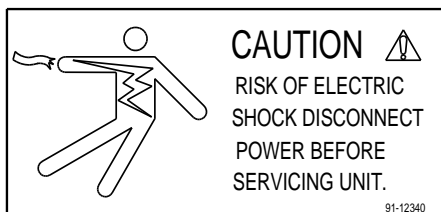

This label is located on the back of the display case.

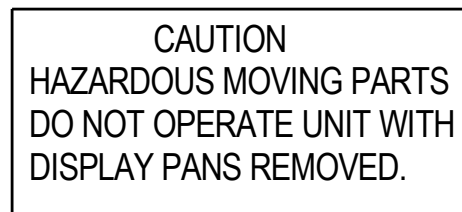

This label is located below the display pan.

GENERAL ELECTRICAL & GROUNDING



DANGER: Improper or faulty hookup of electrical components in the display case can result in severe injury or death.

SELF CONTAINED				
MODEL	VOLTAGE	PERMANENT CONNECTED AMPS	CORD CONNECT AMPS/NEMA PLUG	COMPRESSOR LRA
ITR3626 & ITR3634	120V/60H/1PH	MIN CIRCUIT AMPACITY 13.9/ MAX FUSE SIZE 20	TOTAL AMPS 8.7 / 5-15	TOTAL AMPS 8.7 / 5-15
ITR4826 & ITR4834	120V/60H/1PH	MIN CIRCUIT AMPACITY 16.9/ MAX FUSE SIZE 20	TOTAL AMPS 10.7 / 5-15	TOTAL AMPS 10.7 / 5-15
ITR6026 & ITR6034	120V/60H/1PH	MIN CIRCUIT AMPACITY 17.3/ MAX FUSE SIZE 20	TOTAL AMPS 11.0 / 5-15	TOTAL AMPS 11.0 / 5-15
ITRSS3626 & ITRSS3634	120V/60H/1PH	MIN CIRCUIT AMPACITY 17.11/ MAX FUSE SIZE 20	TOTAL AMPS 13.6 / 5-20	TOTAL AMPS 13.6 / 5-20
ITRSS4826 & ITRSS4834	120V/60H/1PH	MIN CIRCUIT AMPACITY 20/ MAX FUSE SIZE 25	TOTAL AMPS 13.8 / 5-20	TOTAL AMPS 13.8 / 5-20
ITRSS6026 & ITRSS6034	230/60H/1PH	MIN CIRCUIT AMPACITY 13.65/ MAX FUSE SIZE 20	TOTAL AMPS 10.1 / 6-15	TOTAL AMPS 10.1 / 6-15

REMOTE		
MODEL	VOLTAGE	PERMANENT CONNECTED AMPS
ITR3626 & ITR3634 ITRSS3626 & ITRSS3634	120V/60H/1PH	MIN CIRCUIT AMPACITY 15/ MAX FUSE SIZE 15
ITR4826 & ITR4834 ITRSS4826 & ITRSS4834	120V/60H/1PH	MIN CIRCUIT AMPACITY 15/ MAX FUSE SIZE 15
ITR6026 & ITR6034 ITRSS6026 & ITRSS6034	120V/60H/1PH	MIN CIRCUIT AMPACITY 15/ MAX FUSE SIZE 15

DRY NON REFRIGERATED			
MODEL	VOLTAGE	PERMANENT CONNECTED AMPS	CORD CONNECT AMPS/NEMA PLUG
ITD3626 & ITD3634 ITDSS3626 & ITDSS3634 ITDSS3626F & ITDSS3634F	120V/60H/1PH	MIN CIRCUIT AMPACITY 15/ MAX FUSE SIZE 15	TOTAL AMPS 2.0 / 5-15
ITD4826 & ITD4834 ITDSS 4826 & ITDSS4834 ITDSS4826F & ITDSS4834F	120V/60H/1PH	MIN CIRCUIT AMPACITY 15/ MAX FUSE SIZE 15	TOTAL AMPS 2.0 / 5-15
ITD6026 & ITD6034 ITDSS6026 & ITDSS 6034 ITRSS6026F & ITRSS6034F	120V/60H/1PH	MIN CIRCUIT AMPACITY 15/ MAX FUSE SIZE 15	TOTAL AMPS 2.0 / 5-15

(E3788 EXCEL)

Refrigerated Permanent Connected

- Only a licensed electrician must perform all case electrical connections.
- All electrical wiring hookups must be done in accordance with all applicable local, regional, or national electrical standards.
- A separate circuit for each display case is required to prevent other appliances on the same circuit from overloading the circuit and causing malfunction.
- The electrical service must be grounded upon installation.
- See the electrical data plate located at the rear of the case for proper circuit size and wire ampacity.
- The electrical connection box is accessible from the rear of the case with rear grill removed. See grill removal section of this manual for grill removal procedure.

Refrigerated Floor Models:

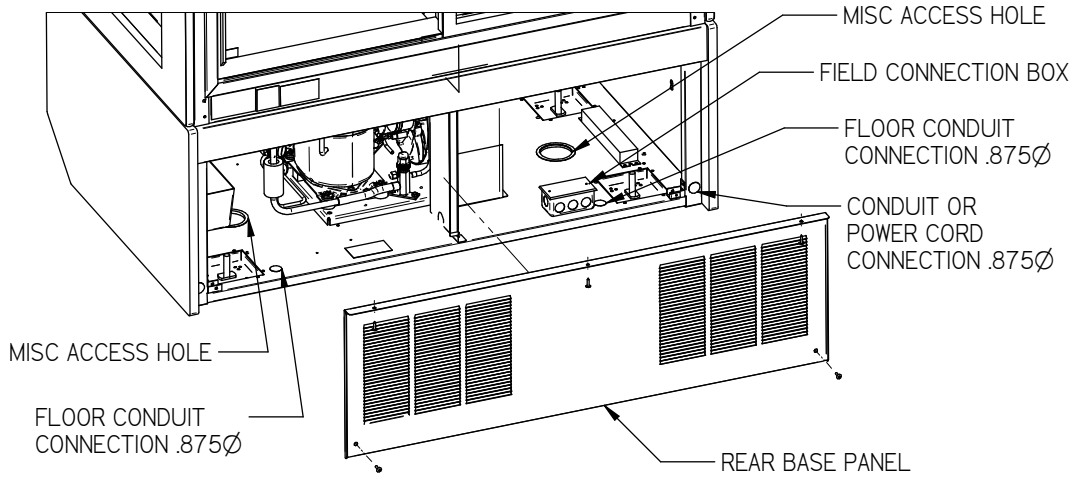

Refrigerated Counter Models:

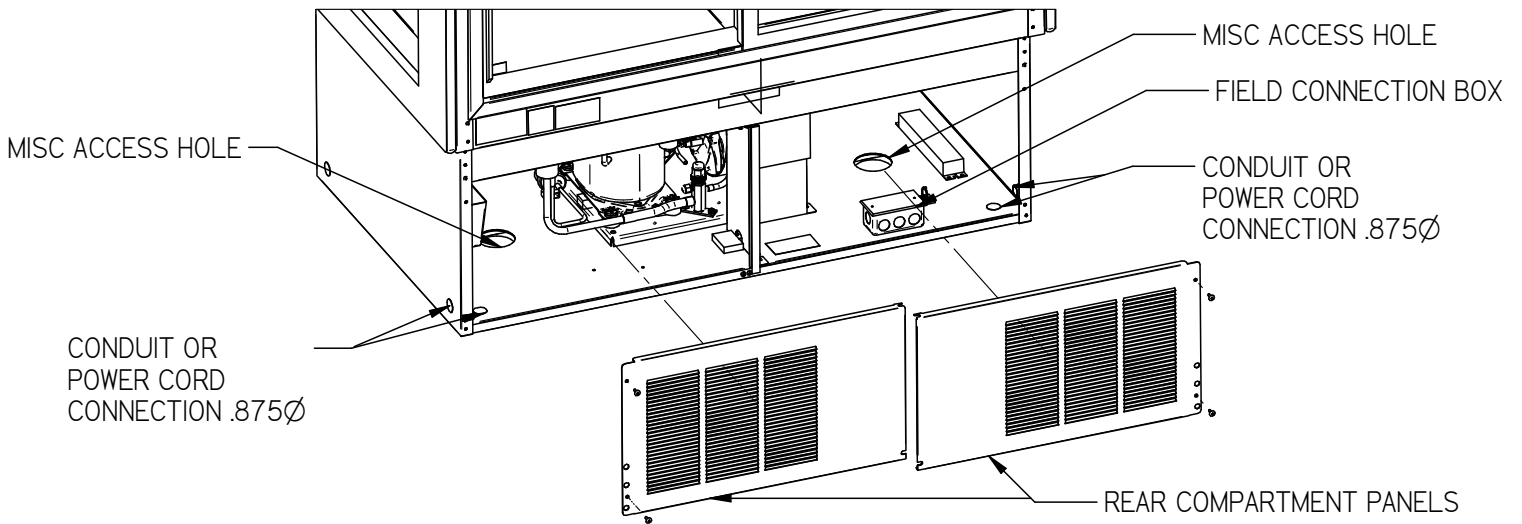

Refrigerated Cord Connected (OPTION)

- A factory installed optional power cord is properly sized to the amperage requirements of the case. See the electrical data plate located on the rear exterior of the case for the proper circuit size for each case.
- The cord is factory installed protruding from the rear corner of the case as noted in above drawings.
- A separate circuit for each display case is required to prevent other appliances on the same circuit from overloading the circuit and causing malfunction.

CAUTION Risk of Electric Shock. If the cord or plug becomes damaged, replace only with a cord and plug of the same type".

Non-Refrigerated Cord Connected (STANDARD)

- A factory installed power cord is properly sized to the amperage requirements of the case. See the electrical data plate located on the rear exterior of the case for the proper circuit size for each case.
- The cord is factory installed protruding from the rear corner of the case as noted in below drawings.
- A separate circuit for each display case is required to prevent other appliances on the same circuit from overloading the circuit and causing malfunction.

 **CAUTION** Risk of Electric Shock. If the cord or plug becomes damaged, replace only with a cord and plug of the same type".

- Only a licensed electrician can move the electrical cord connections to opposite end of case as shown in drawings below.

NON-Refrigerated Floor Models:

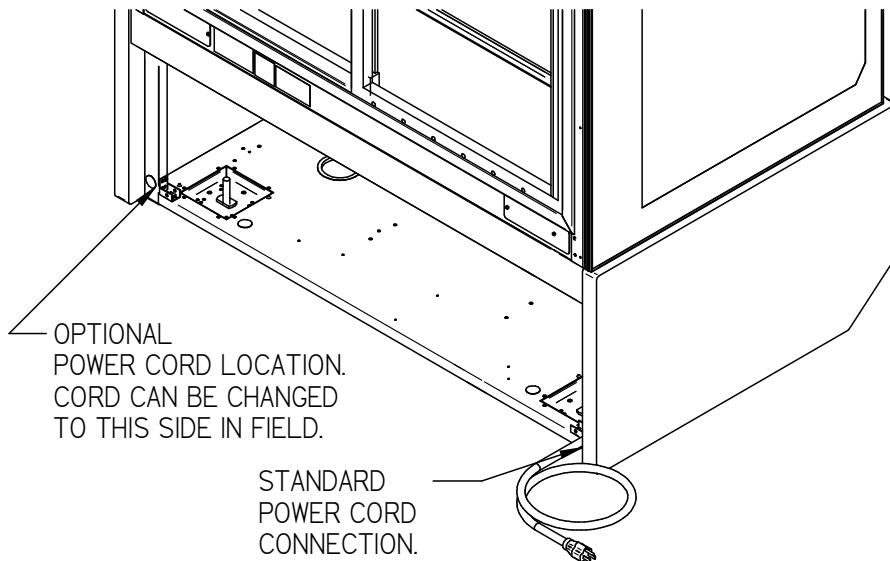

NON-Refrigerated Counter Models:

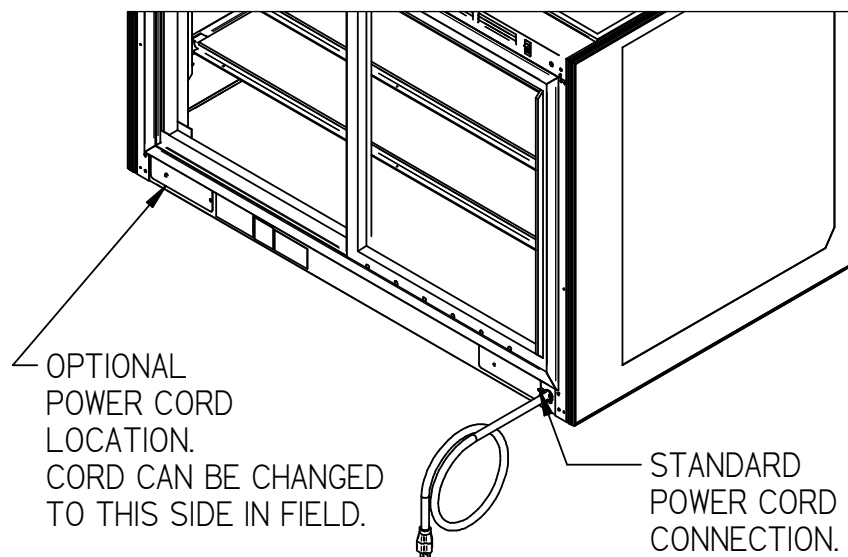

REFRIGERATION

Self-Contained Models

MODEL	R134A CHARGE PRE 12/1/19	R513A CHARGE POST 12/1/19	REFRIGERATION
ITR3626 & ITR3634 & ITRSS3626 & ITRSS3634	18 OZ	17 OZ	1/2HP
ITR4826 & ITR4834 & ITRSS4826 & ITRSS4834	20 OZ	19 OZ	1/2HP
ITR6026 & ITR6034 & ITRSS6026 & ITRSS6034	24 OZ	23 OZ	1/2HP

The self-contained models manufactured before 12/1/19 are shipped from the factory with a completely operational 134A refrigeration system and require no modifications or adjustments upon installation. Models produced after 12/1/19 are shipped with 531A. Case must be installed per the installation section of this manual to provide proper condensing air cooling.

Self-Contained Refrigeration Operation

The unit temperature is controlled by an electronic control that senses air temperature and turns refrigeration on and off as required to maintain proper temperature.

The electronic control will also sense a frosted coil that requires a defrost cycle and shuts off refrigeration until defrost is complete. There are also a defined number of scheduled defrosts that also shut the refrigeration off to insure a full defrost.

Remote Models Use pressure gauges to set pressure control

MODEL	REFRIGERANT PRE 12/1/19	REFRIGERANT POST 12/1/19	REFRIGERATION	PRESSURE CUT IN	PRESSURE CUT OUT
ITR3626R & ITR3634R & ITRSS3626R & ITRSS3634R	R134A	R531A	3400 BTUH@90F/20F	25#	5 #
ITR4826R & ITR4834R & ITRSS4826R & ITRSS4834R	R134A	R531A	3800 BTUH@90F/20F	25#	5 #
ITR6026R & ITR6034R & ITRSS6026R & ITRSS6034R	R134A	R531A	4200 BTUH@90F/20F	25#	5 #

Use pressure gauges to set pressure control

Remote Refrigeration Operation

The remote models manufactured before 12/1/19 are designed to use 134A refrigerant and after 12/1/19 are designed to use R531a refrigerant and shipped from the factory with the evaporator coil, expansion valve, drier filter, sight glass and refrigerant solenoid valve. The required high-low-pressure control and remote condenser can be provided as a factory option and will be required to be charged with 134a or R531A refrigerant after installation.

The unit temperature is controlled by an electronic control that senses air temperature and opens and closes the refrigerant solenoid valve as required to maintain proper temperature.

Once proper temperature is reached the solenoid valve closes and shuts off the refrigeration flow to the unit and initiates a pump down cycle. This will allow the remote low pressure switch to open and shut off remote compressor. The solenoid will remain closed until the electronic control probe reaches its “cut in” set point. The electronic control will also sense a frosted coil that requires a defrost cycle and closes solenoid until defrost is complete. There are also a defined number of scheduled defrosts that also insures a full defrost occurs.

Remote Refrigeration Installation

The condensing unit and pressure control are optionally supplied from the factory for remote location installation. A remote high low-pressure switch must be mounted and wired by the installer. The high low-pressure switch must be wired in series with the compressor power supply as shown in diagram below.

1. Mount condensing unit as close to the remote display case as practical. All refrigeration and/or electrical materials between the condensing unit and display case are to be supplied by installing contractor.
2. Route properly sized and designed refrigeration lines from the condensing unit to the cabinet. Follow line sizing charts and piping instructions in the condenser unit’s manufacturers instruction manual. Horizontal suction lines should be pitched downward towards the condensing unit at least ½” per 10’ run to aid the oil drainage. A “P” trap must be installed in the suction line at the foot of every riser to insure oil return. Dry nitrogen must be used to flow through tubing while brazing refrigeration lines.
3. Suction line must be insulated the entire length with Armaflex (or equivalent). Do not run liquid line inside insulation with suction line.
4. The remote high/low-pressure control must be mounted, wired and set by the installer.
5. Leak check condensing unit, cabinet, and all connecting tubing. Cabinet and condensing unit tubing should be checked to insure no leaks occurred during shipping or from rough handling. Make certain all refrigeration valves are opened and evacuate system below 500 microns. System must hold below 500 microns for 1 minute with pump isolated. Charge the system with refrigerant type specified on the data plates.

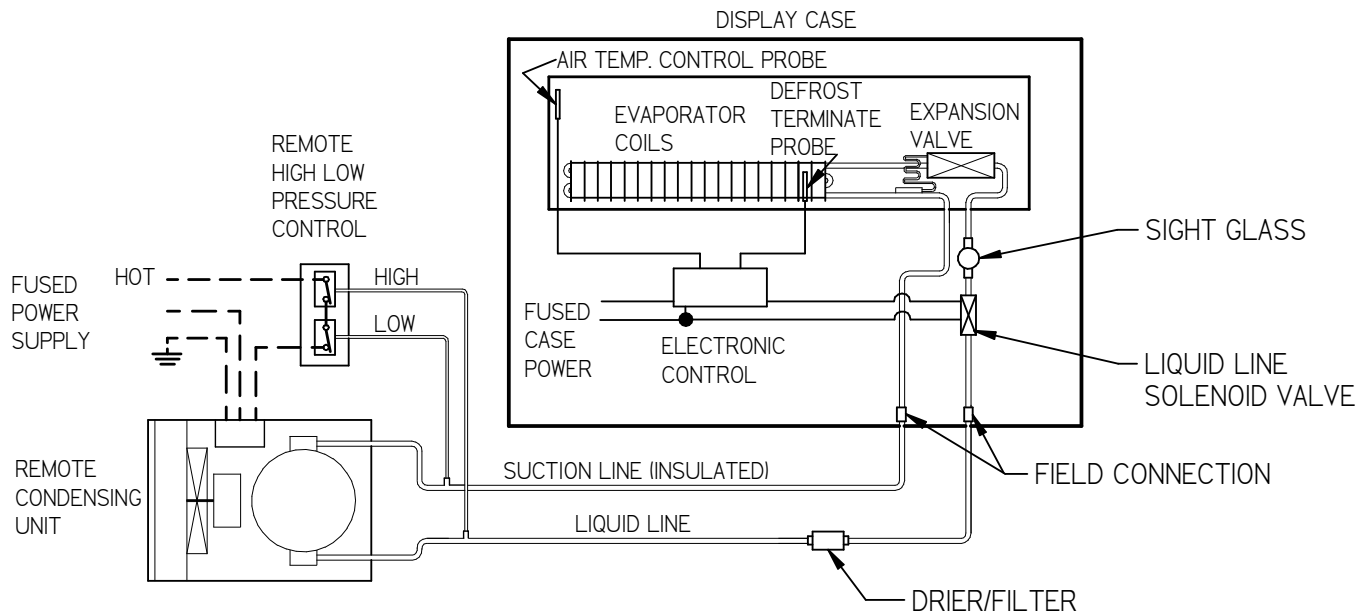

Condensate Evaporator Pan and Pump

Condensate Evaporator (Standard Self-Contained Models)



NOTICE: During normal defrost cycles, steam from the condensate evaporator may be visible around the case.

The standard Self-Contained case is furnished with an electric condensate evaporator. Plumbing connections are not required.

The condensate evaporator can be removed from the case and the condensate drain can be plumbed to a drain to conserve energy if desired. Disconnect the condensate evaporator wires at the condensate evaporator to remove. This must be done by a qualified electrician.

Make sure that the drain line has not been dislodged during shipment and that the drain trap terminates properly over the water reservoir.

Condensate Pump (Standard Remote, optional Self Contained)

NOTICE: This unit could be shipped with an optional condensate pump. The pump has a float that turns the pump on automatically when needed. The pump is mounted in the base compartment. The pump should be cleaned and inspected every 3-4 months.

When unit is shipped with a condensate pump a condensate discharge hose is supplied from factory. This hose must be run to a nearby drain. When the condensate pan is full the pump will turn on and pump water out condensate drain hose. Note Drain hose can be run in vertical direction but must not exceed height of 15 feet

Note: There is a piece of cardboard that has to be removed from the side of the pump to free up the float. If this is not done, the pump will not turn on and the pan will overflow.

Electronic Expansion Valve (EEV) After 1/20

A traditional TXV uses springs and a temperature bulb to open and close a valve port that controls the flow of refrigerant entering the evaporator coil. An electronic expansion valve (EEV) controls the refrigerant flow much more precisely, increasing the performance and efficiency of the refrigeration system. The EEV controls the flow of Refrigerant by opening and closing the valve port based on the response to signals sent to the EEV by an electronic controller. The electronic Control bases these signals by processing information provided from a temperature sensor and pressure transducer located on the discharge side of the evaporator coil.

These sensors monitor the evaporator superheat and protects the compressor from any liquid flood back under low superheat conditions.

EEV Controller Settings

The electronic expansion valve controller also allows the use of different types of refrigerants without the need to change the expansion valve.





The controller is set from the factory to run on 449A refrigerant and will not need any changes to the control unless another refrigerant is used.

Note: Check your State and Local regulations for approved refrigerants for your install location. Federal Industries is not liable for any alternate refrigerants used.





The control is located in the rear center of the base.

Note: Never change any of the other setting other than the refrigerant type. It may also be necessary to change the superheat setting only when using a different refrigerant.







Indicator lights	
	Red light - critical alarm (system is NOT running)
	Yellow light - non-critical alarm (system running)
	Green light - compressor on
	Green blinking - compressor waiting on timer to start/stop

Changing Refrigerant

- Access the set point mode by pressing and holding the **ENTER** button until Ctl displays on the screen.
- Use the  up or  down arrows to advance through the available set points until rFG displays on the screen and press the **ENTER** button.
- Use the  up or  down arrows until the desired refrigeration displays on the screen and press and hold the **ENTER** button until rFG once again displays on the screen.
- Press the **BACK** to return to escape the settings menu.

Changing Superheat

- Access the set point mode by pressing and holding the **ENTER** button until Ctl displays on the screen.
- Use the  up or  down arrows to advance through the available set points until SSP displays on the screen and press the **ENTER** button.
- Use the  up or  down arrows to set the desired superheat displays on the screen and press and hold the **ENTER** button until SSP once again displays on the screen.
- Press the **BACK** to return to escape the settings menu.

BASE COMPONENT LAYOUTS

Refrigerated Self Contained Models

Counter ITR & ITRSS 36 Self Contained

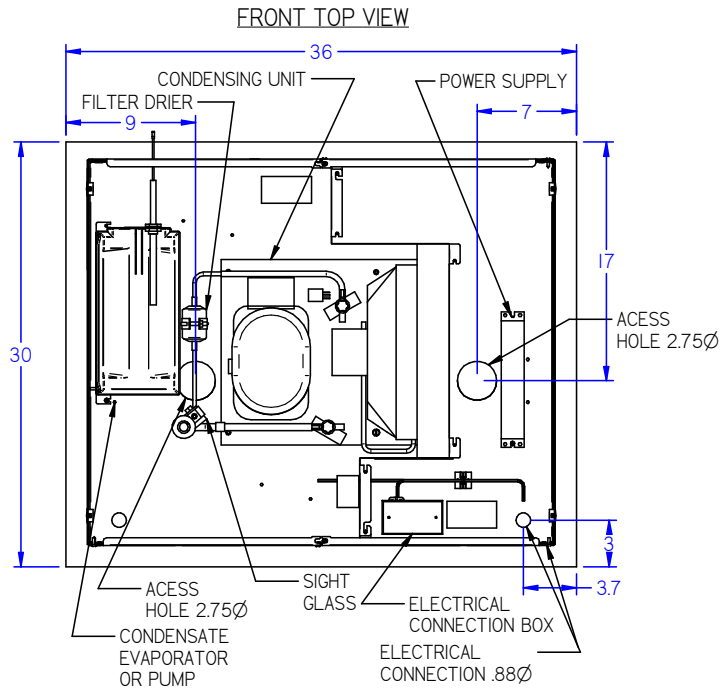

Counter ITR & ITRSS 48 Self Contained

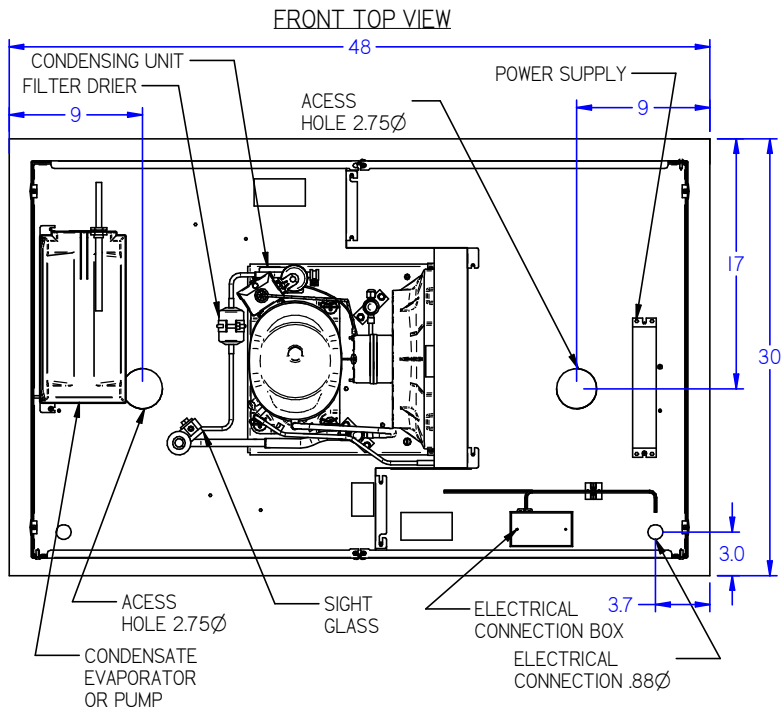

Counter ITR60 Self Contained

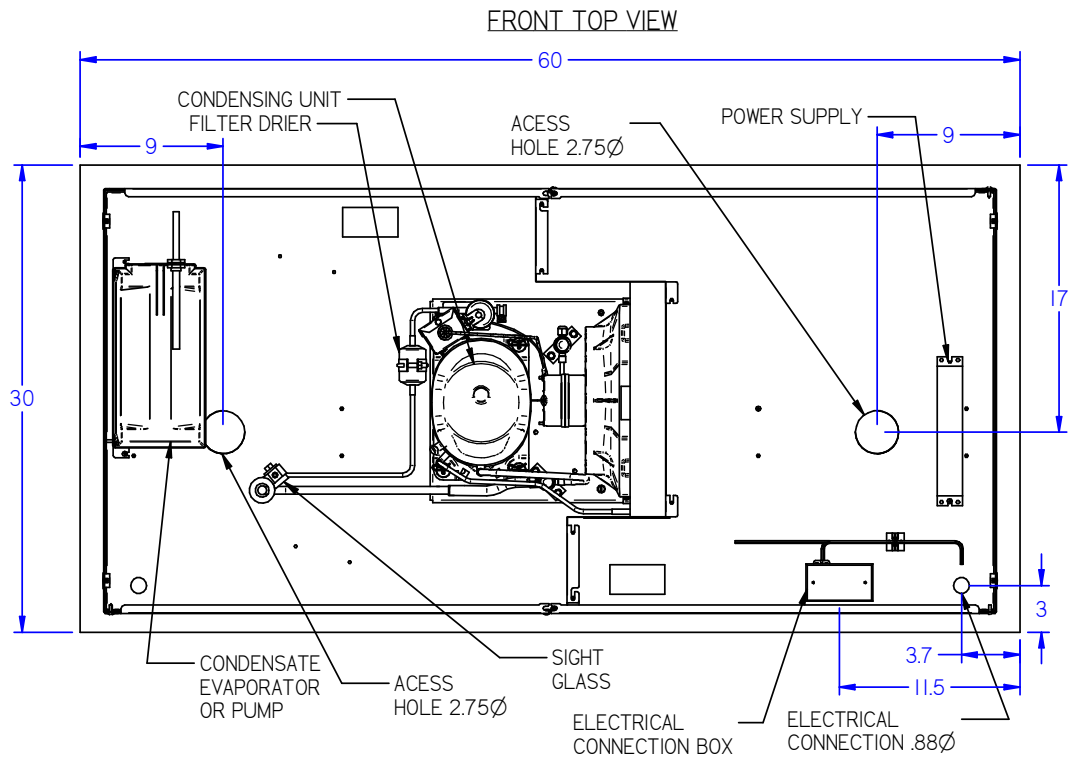

Counter ITRSS60 Self Contained

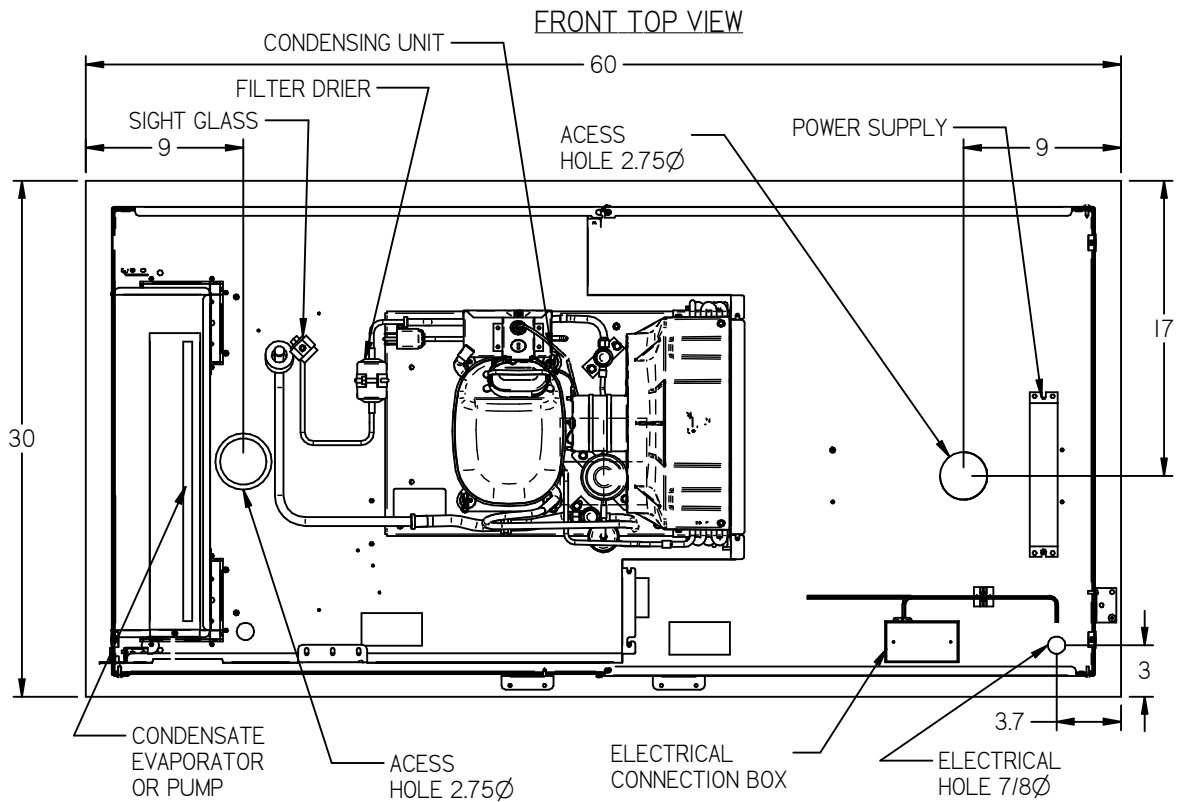

Floor ITR & ITRSS 36 Self Contained

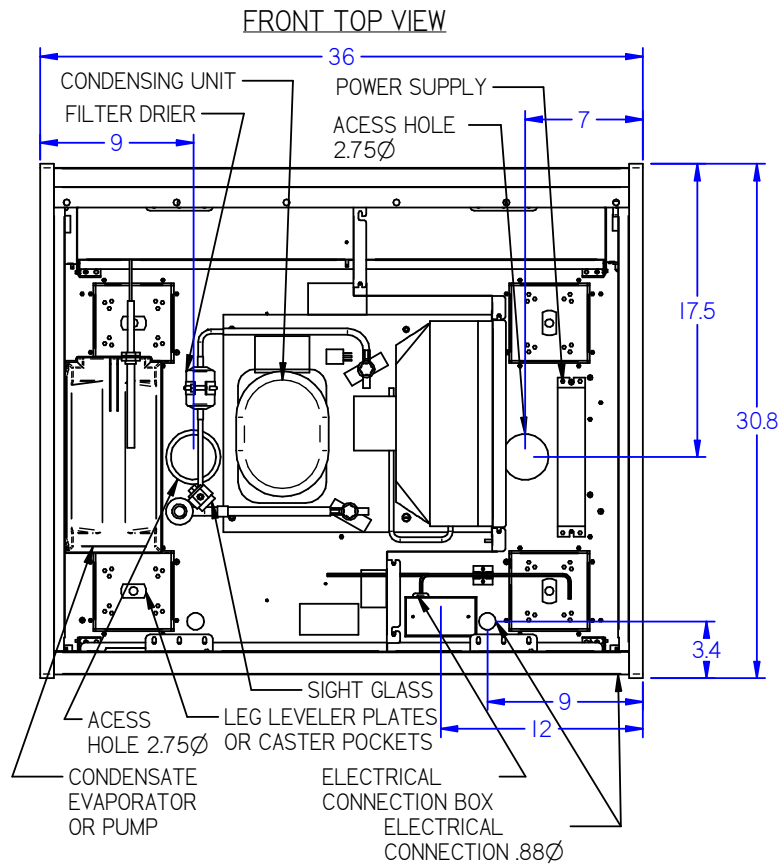

Floor ITR & ITRSS 48 Self Contained

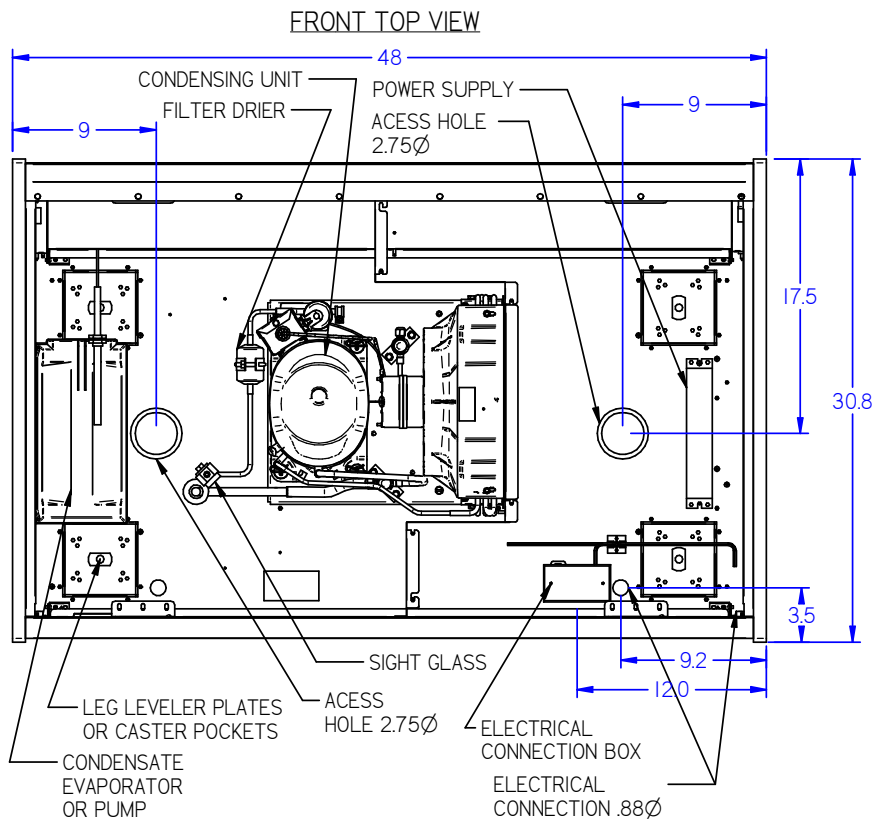

Floor ITR60 Self Contained

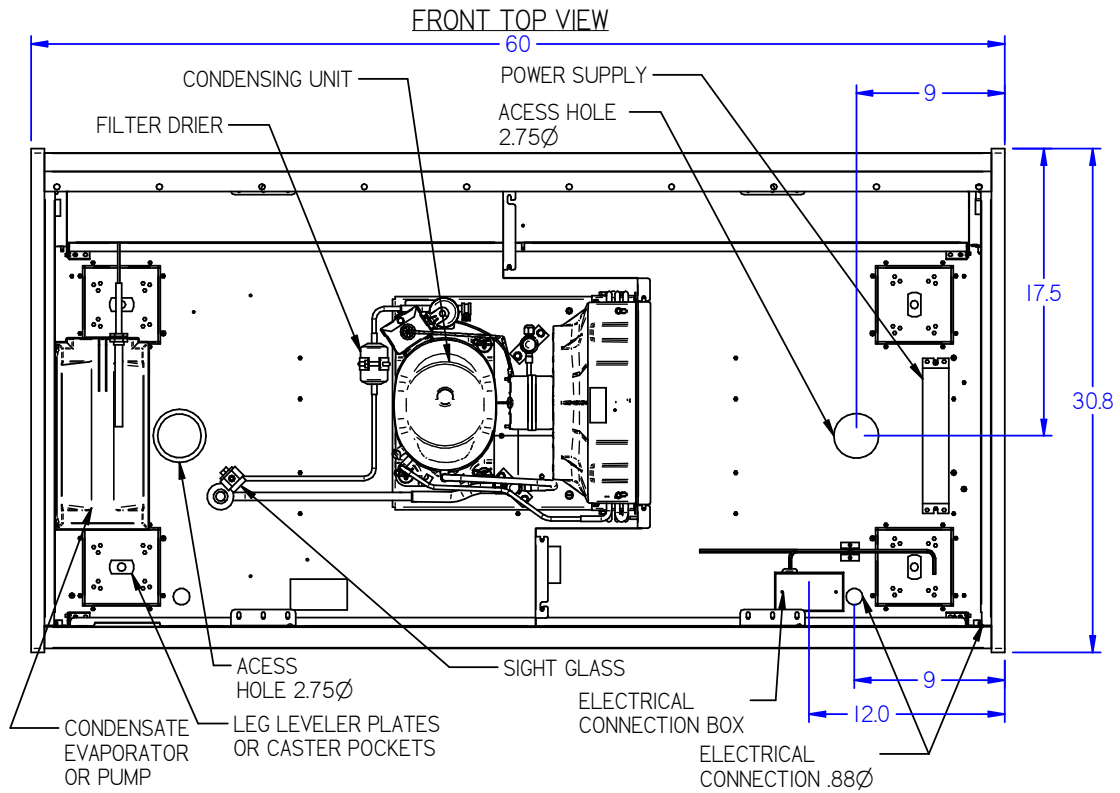

Floor ITRSS60 Self Contained

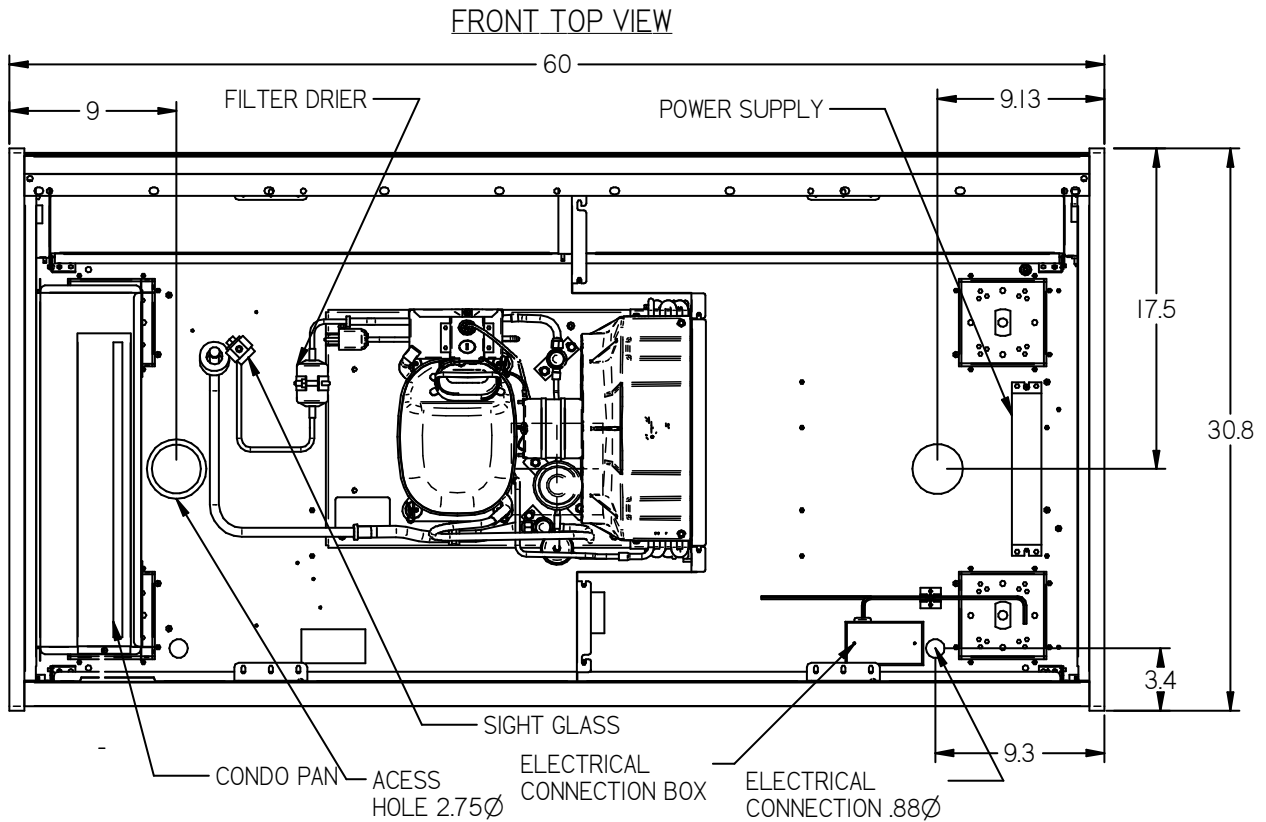

Refrigerated Remote Models

All ITR Counter Remote

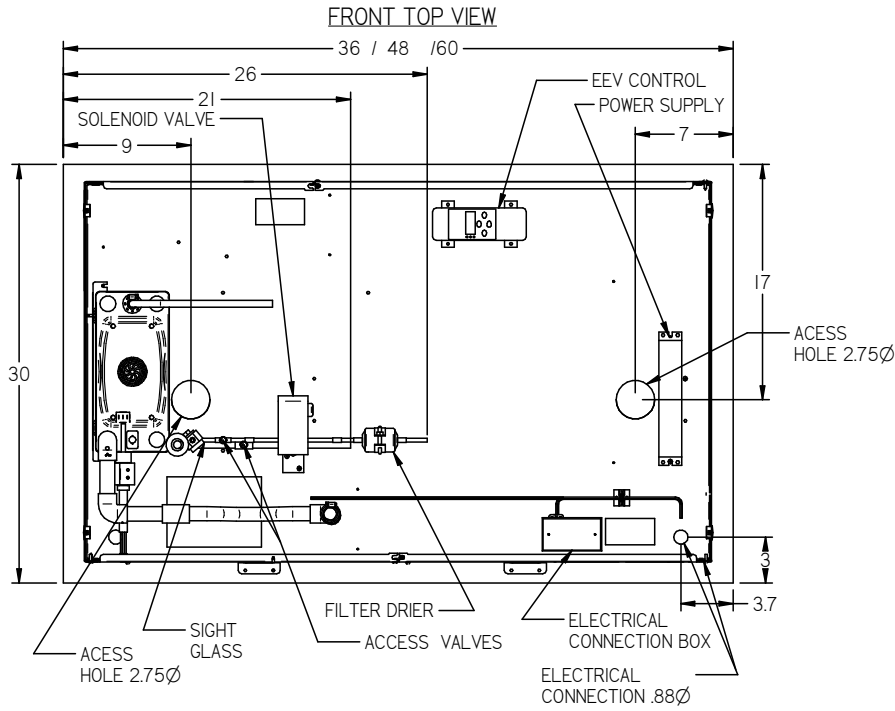

All ITR Floor Remote

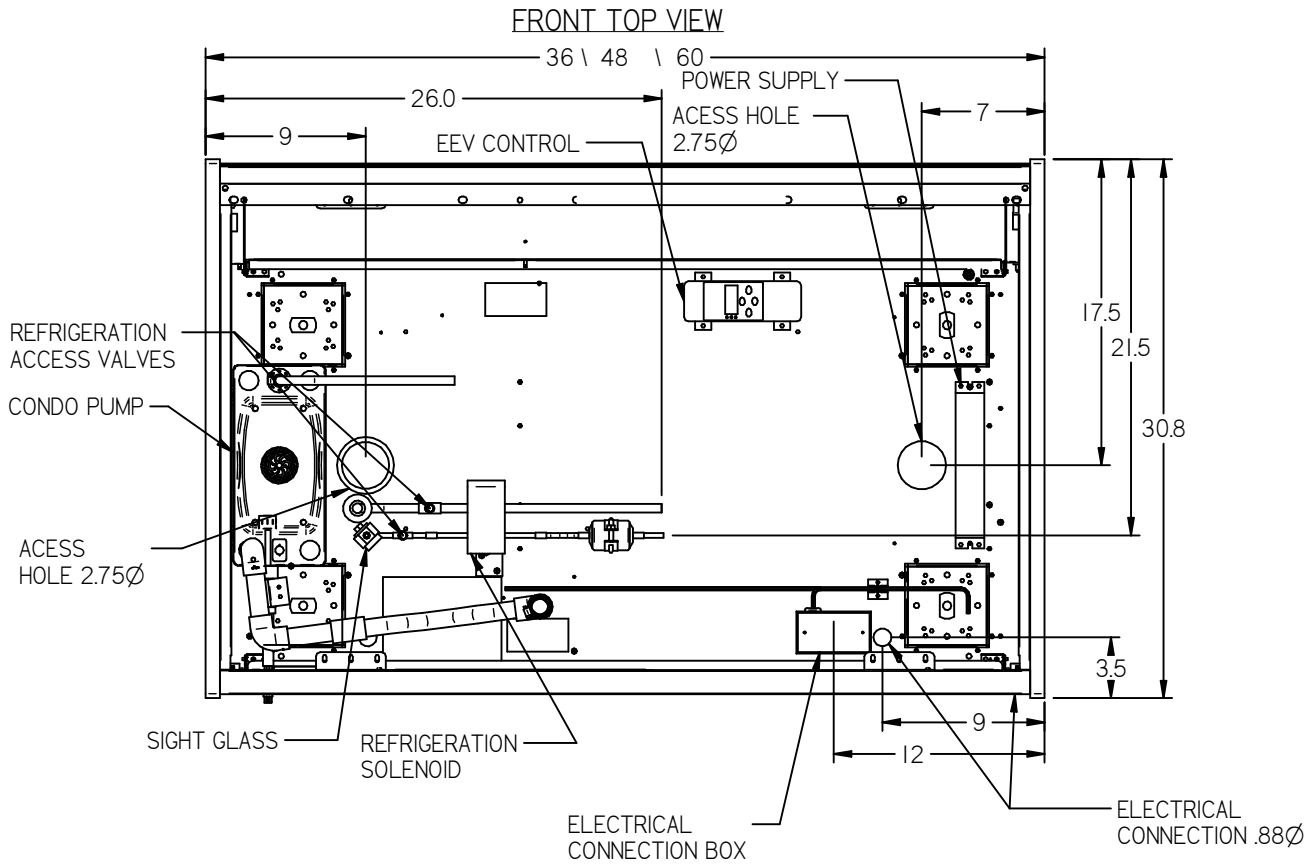

All ITRSS Counter Remote

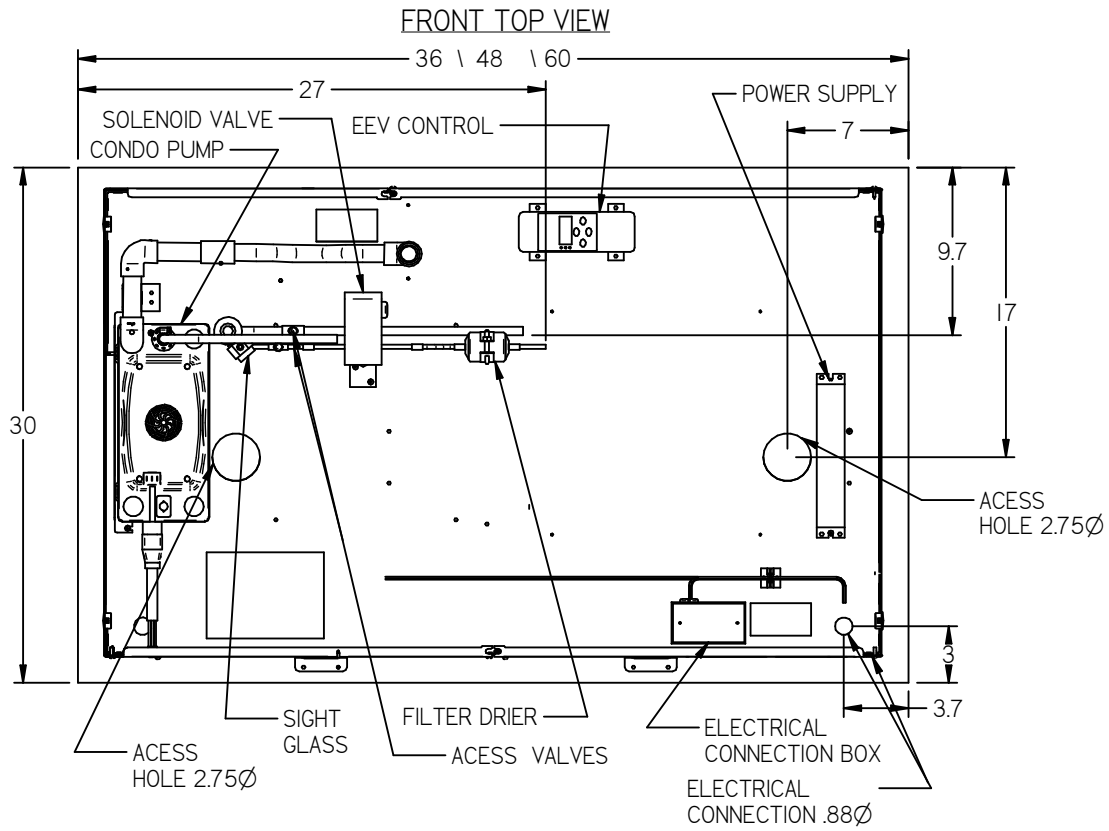

All ITRSS Floor Remote

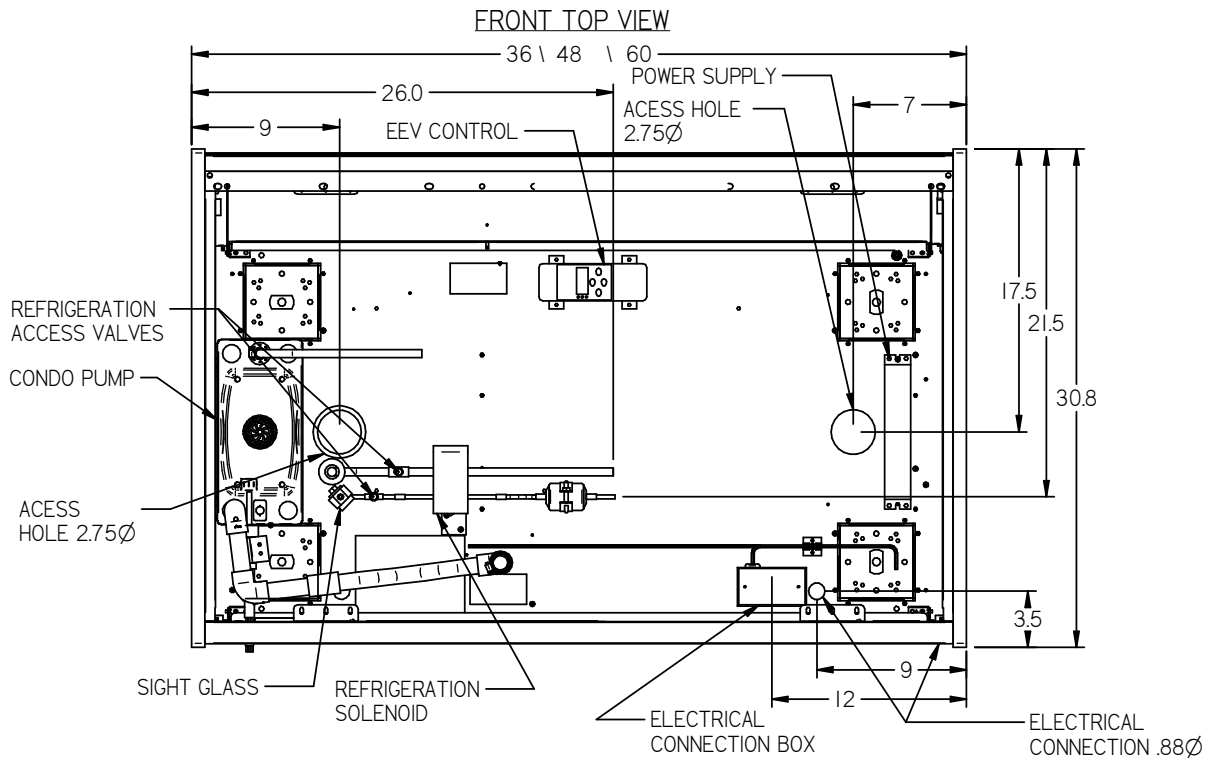

Floor ITD, ITDSS & ITDSSF NON-Refrigerated

There are no components in base on NON-Refrigerated models so no base layout is provided
Light Power Supply is located on top of case under the top cover. See Removal Section of this Manual.

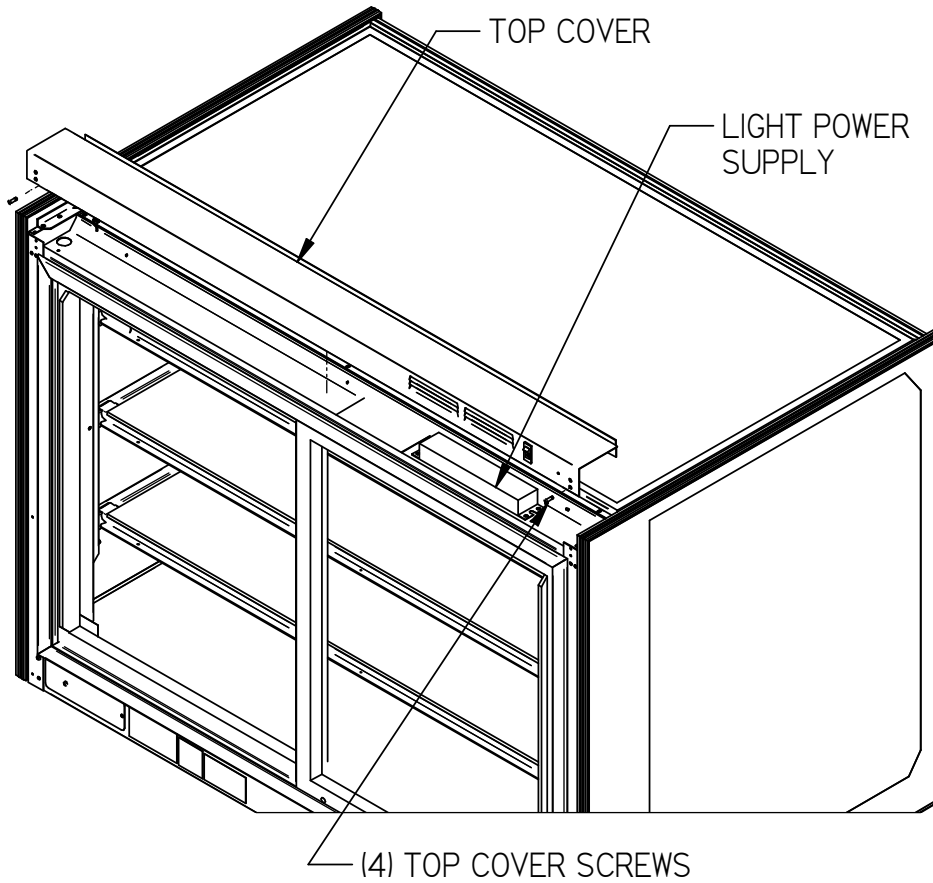

INSTALLATION INSTRUCTIONS FLOOR MODELS

Inspection for Shipping Damage

You are responsible for filing all freight claims with the delivering truck line. Inspect all cartons and crates for damage as soon as they arrive. If damage is noted to shipping crates, cartons, or if a shortage is found, note this on the bill of lading (all copies) prior to signing.

Locating Display Case

The case must be located where it is not subjected to the direct rays of the sun, heating ducts, grills, radiator, or ceiling fans, nor should it be located near open doors or main door entrances. Also, avoid locations where there are excessive air movement or air disturbances.

The case requires a minimum of 36" clearance on side of air intake or air discharge. Do not locate case with front or back tight against the wall.

No clearance is needed on sides of the unit.

Removing Case from Shipping Skid and General Installation



CAUTION: Do not push or pull against the top end glass, or door frames and do not pull on end panels when removing the case from the skid or moving the case. Case damage or glass breakage will result.

1. Remove crate top and sides and note missing or damaged items as explained in the pre-installation procedures outlined above.
2. Move the case as near as possible to the final location and before removing it from the shipping skid.
3. On Counter Model Units, the case is held to skid with (4) brackets on each outside corner of the case. Remove the screws that secure these (4) brackets to the skid and case.
On Base Model Units, there are (4) bolts through the skid and into each corner of the base of unit. Remove the front and back base panels as described in this manual. Remove the (4) nuts and bolts holding unit to skid.
4. Prepare cabinet according to instructions in this section that pertain to your model.
5. Lift the case off of skid and into required position. Only lift the case from under the front and rear lips on base or frame of unit.
6. The case must be level for proper drainage of defrost condensate to the condensate evaporator or pump. Using the wrench provided level and square the case as needed by adjusting the leg leveler in each corner of base.
7. The leveled case must be sealed to the floor using a NSF Listed Sealant.

Additional Parts Shipped with Unit.

Remove bubble wrap and packing material for all shelves and panels, brackets, etc. If it is necessary to remove tape residue from plastic materials, use cleaning compounds recommended in the cleaning section of this manual. Install panels and shelving as described proper section of this manual.

Cleaning

For initial setup, clean the case as outlined in the "Weekly Cleaning" section of this manual.

INSTALLATION INSTRUCTIONS COUNTER MODELS

Inspection for Shipping Damage

You are responsible for filing all freight claims with the delivering truck line. Inspect all cartons and crates for damage as soon as they arrive. If damage is noted to shipping crates, cartons, or if a shortage is found, note this on the bill of lading (all copies) prior to signing.

Locating Display Case

The counter units are designed to be placed on or into the top of a cabinet counter. The cabinet that the case is to be used with must be located where it is not subjected to the direct rays of the sun, heating ducts, grills, radiator, or ceiling fans, nor should it be located near open doors or main door entrances. Also, avoid locations where there are excessive air movement or air disturbances.

The refrigerated cases require special consideration of cabinet design to allow condenser air to enter intake and discharge from cabinet space. The requirements for specific cases outlined in this section must be followed. Failure to follow these instructions will void warranty.

Removing Case from Shipping Skid and General Installation



CAUTION: Do not push or pull against the top end glass, or door frames and do not pull on end panels when removing the case from the skid or moving the case. Case damage or glass breakage will result.

1. Remove crate top and sides and note missing or damaged items as explained in the pre-installation procedures outlined above.
2. Move the case as near as possible to the final location and before removing it from the shipping skid.
3. Remove the (4) brackets that secure the case to the shipping skid.
4. Prepare cabinet according to Cabinet Mounting Counter Models instruction in next section that pertain to your model.
5. The counter cases are shipped with end glass removed and lifting handles are provided on each side of case. Using lifting handles lift the case off of skid and into required position. Once case is placed into position remove lifting handles and install end glass as described in End Glass Installation Section
6. The counter top that the case is being placed on must be level for proper drainage of defrost condensate to the condensate evaporator or pump.
7. The case must be sealed to the counter using a NSF Listed Sealant.

Additional Parts Shipped with Unit.

Remove bubble wrap and packing material for all shelves and panels, brackets, etc. If it is necessary to remove tape residue from plastic materials, use cleaning compounds recommended in the cleaning section of this manual. Install panels and shelving as described proper section of this manual.

Cleaning

For initial setup, clean the case as outlined in the “Weekly Cleaning” section of this manual.

ITD, ITDSS & ITDSSF Non-Refrigerated Model Cabinet Mounting

Cabinet Preparation

The ITD models set directly on top of counter. The Case must be attached and sealed to top of counter to prevent counter from moving. Counter will require (2) 3/8" dia. holes to be drilled through the counter top surface to attach case to counter. Use the diagram below for hole location.

Place case on to counter and fasten from under cabinet with (2) 10-32 screws and washers provided. The case must be sealed to the counter using a NSF Listed Sealant.

IMPORTANT: When placing cases in a line up the number of end panels used will be different. The cut out and hole placement dimension will need to be adjusted for each particular line up circumstance.

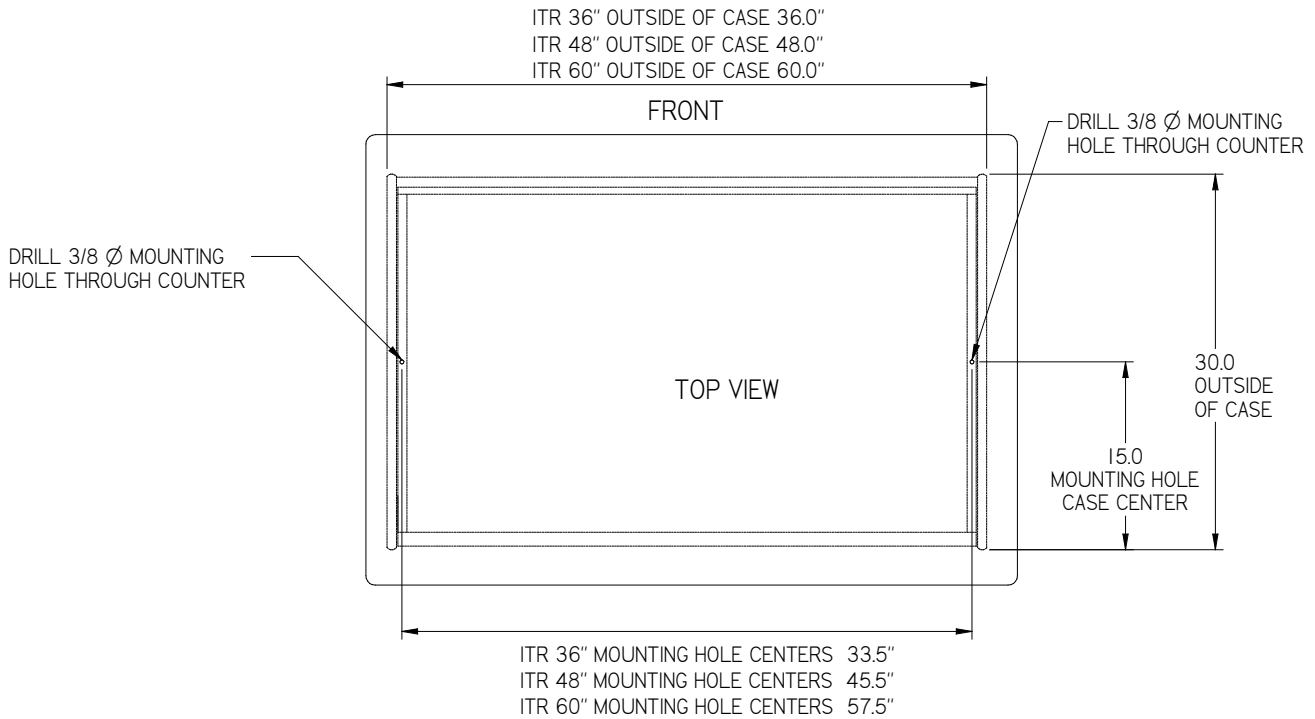

ITR Refrigerated Models Cabinet Mounting

Cabinet Preparation

The ITR models have a large compartment hanging from the bottom of case. On the Self-Contained models it contains the condenser and condensate evaporator, on the Remotes it contains the condensate pump or condensate evaporator and fan. This compartment hangs inside the cabinet compartment and the interior of the cabinet must be open to allow space for this compartment.

Cabinet Cutout

The countertop must be cut to allow the case's base and condenser compartment to drop into the cabinet interior. On refrigerated self-contained and remotes with optional condensate pan the Grill cut outs must be cut in back of cabinet to allow air flow in and out of refrigeration compartment. Use the diagram below for cutout dimensions.

IMPORTANT: When placing cases in a line up the number of end panels used will be different. The cut out and hole placement dimension will need to be adjusted for each particular line up circumstance. See Continues Line up drawing below.

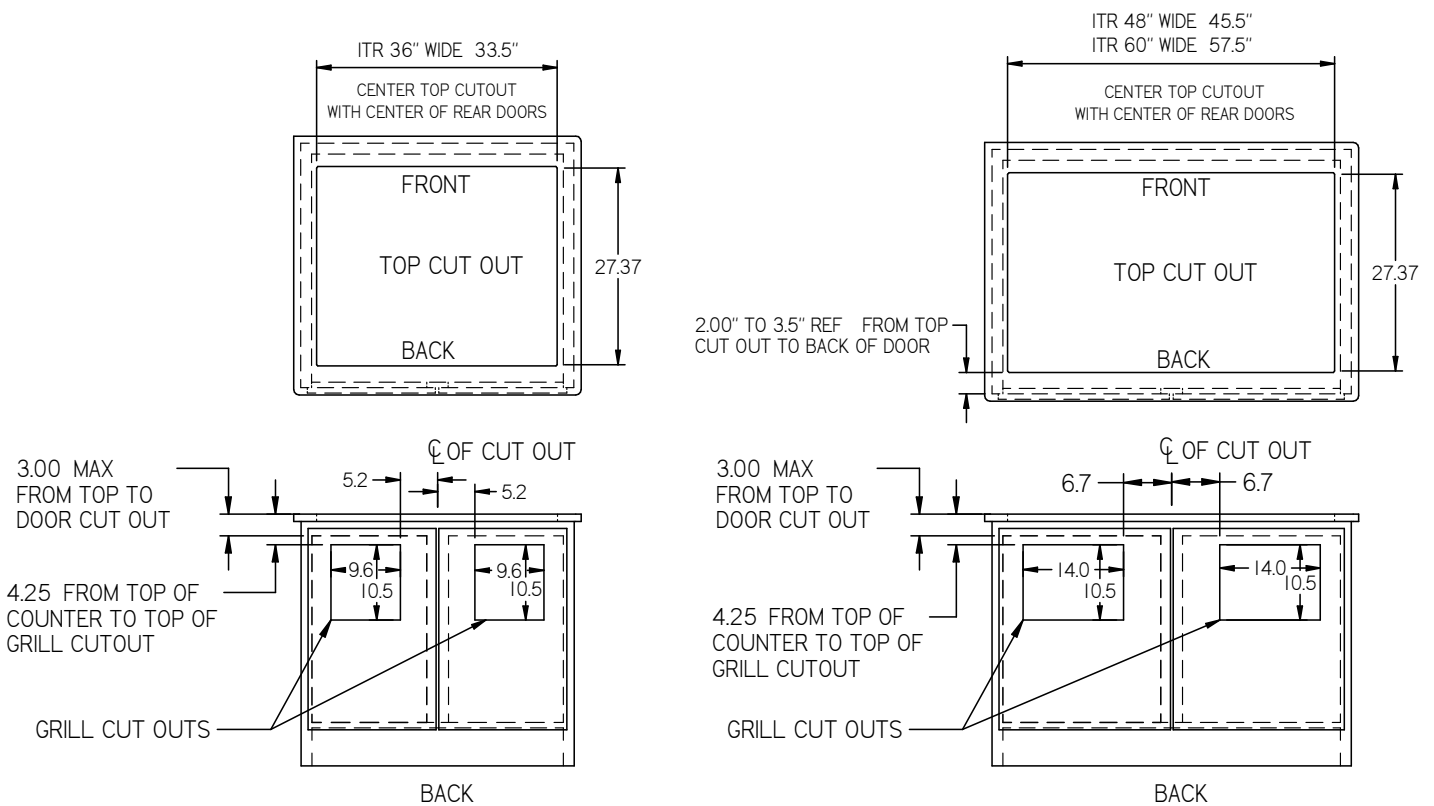

Continues Line Up Cut Outs (Note: Dry Cases do not require cut out in counter)

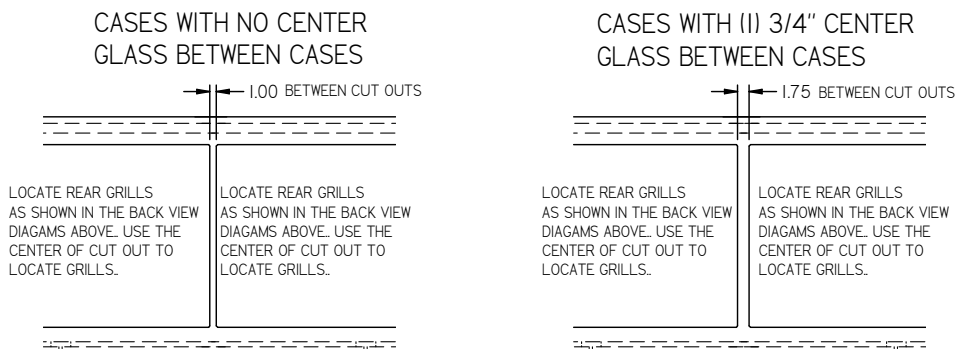

Case Install

The Inner Outer Duct Assemblies and Retainer Brackets are shipped attached to the case refrigeration compartment. The Duct Assemblies and Retainer Brackets must be removed before setting case into cabinet opening. To disassemble remove the (8) screws holding each Duct Assembly to the louvered panel also remove the (2) screws holding each Retainer Bracket.

Lift handles and screws are shipped loose with case. To use the provided handles, remove the end glass panels as described in the End Panel Installation section of this manual. There are holes provided in the side rails of case in the location shown below. Attach handles using the provided 1/4-20 screws. Be sure to use gloves to prevent injury and use handles to lift case into cabinet. Once case is placed into cabinet remove the (4) handles and install side glass as described in End Panel Installation section of this manual.

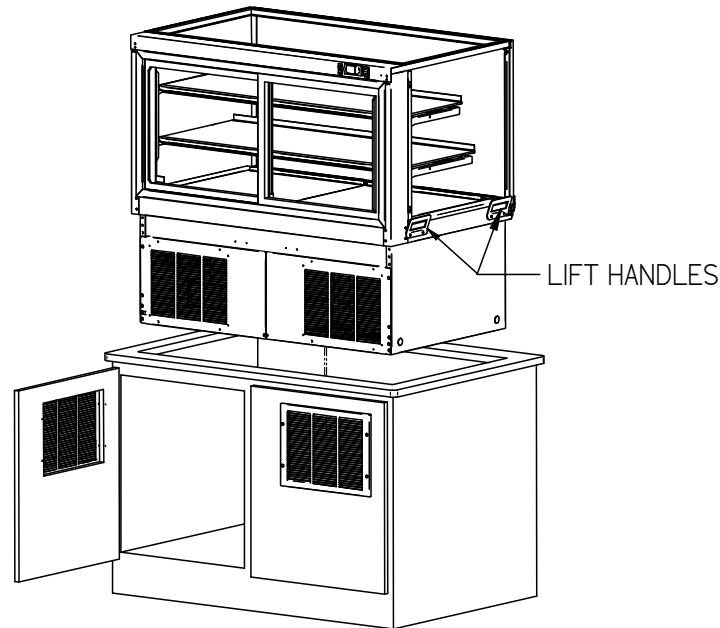

Once case is in place it must be secured to prevent it from moving during use. Reattach the Retainer Brackets that were previously removed in same location using the #8 hex head screws. Push bracket up tight to bottom of counter top and tighten screws. Pre-drill (4) 5/32 holes 1/2" deep into the counter top. (Be careful not to drill through top of counter)

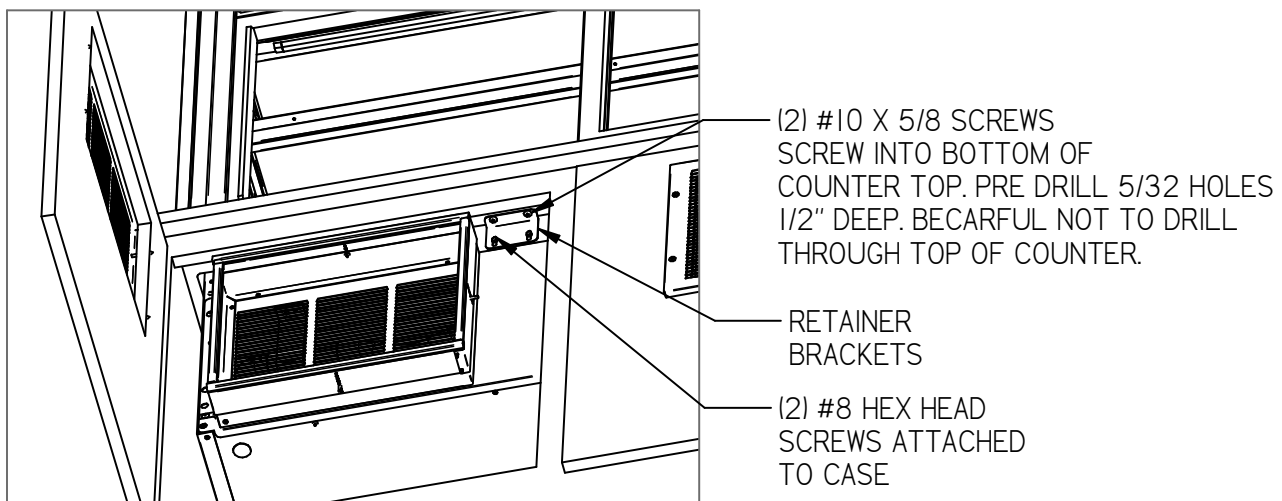

Cabinet Grills & Air Duct (All refrigerated self-contained and remotes with condo pan)

IMPORTANT: Federal Industries reserves the right to deny warranty if the cabinet is not ducted to allow proper condenser and condensate air intake and discharge, or if the cabinet louvers are not installed properly, or if condenser air intake and discharge air is blocked or located near a source of heat.

The condenser air intake and discharge must be separated and vented out of the cabinet compartment for case to operate. The required louver grills and expandable ducts for both intake and discharge are provided with case. On Remotes, the louvers are required to vent the moist condensate air.

Note: The louvered panels mounted to condenser compartment are located on the back of the compartment and solid panels are mounted to front of the compartment when shipped from factory. This set up is for air intake and discharge out of the back of the cabinet. The intake and discharge louvered panels can be moved to front of compartment and the solid panels moved to the back of compartment if air intake and discharge is required out of front of cabinet

The Outer Duct must be adjusted so that the gasket seals against the Cabinet Door. Remove the (4) screws located inside of the Outer Duct. There are multiple holes in the Outer Duct. Move Outer Duct to desired depth and reinstall (4) screws. Open & close door and be sure Gasket seals hits door

Center the supplied Grills on outside of Cabinet Doors and mark holes onto doors. Drill 1/8 holes into door in marked positions. With Grill flanges against door screw Grill to cabinet door with (4) supplied #8 x1-1/4 screws.

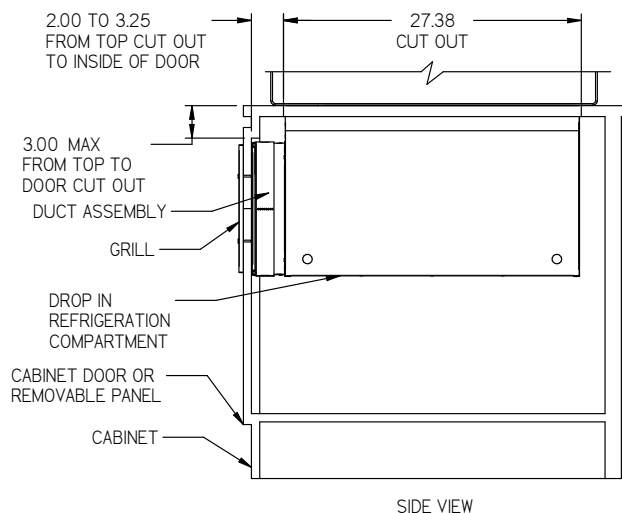
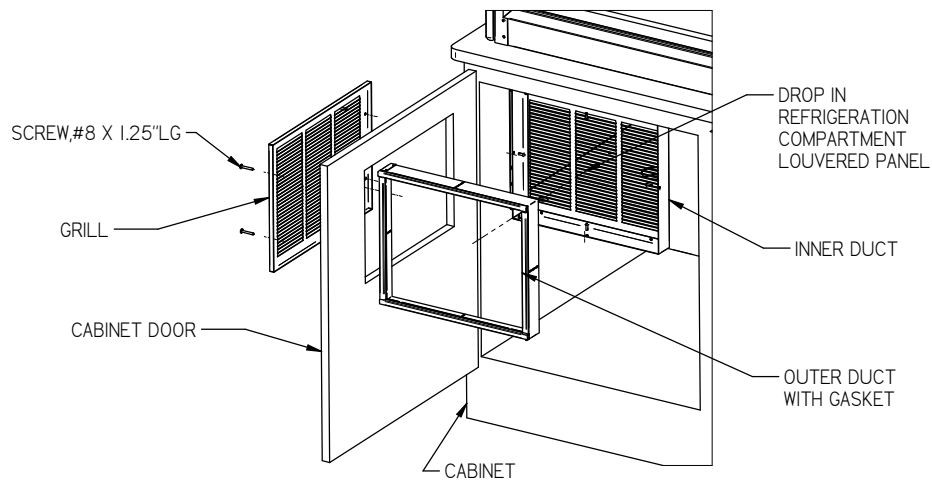

Joining Cases (No End Glass Between)

ONCE TOP JOIN TRIM IS IN DESIRED LOCATION ATTACH TO CASE WITH (2) 8-18 SELF DRILLING SCREWS.

DETAIL B

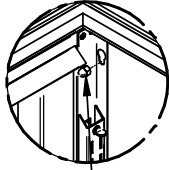

SLIDE EDGE OF TOP JOINING TRIM UNDER PLASTIC GLASS LIP

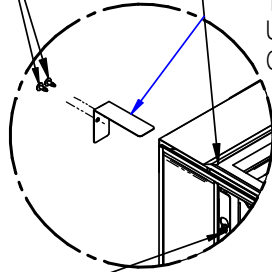

DETAIL C

ALIGN CASES AND JOIN TOGETHER WITH (4) 1/4-20 SCREWS AND NUTS.

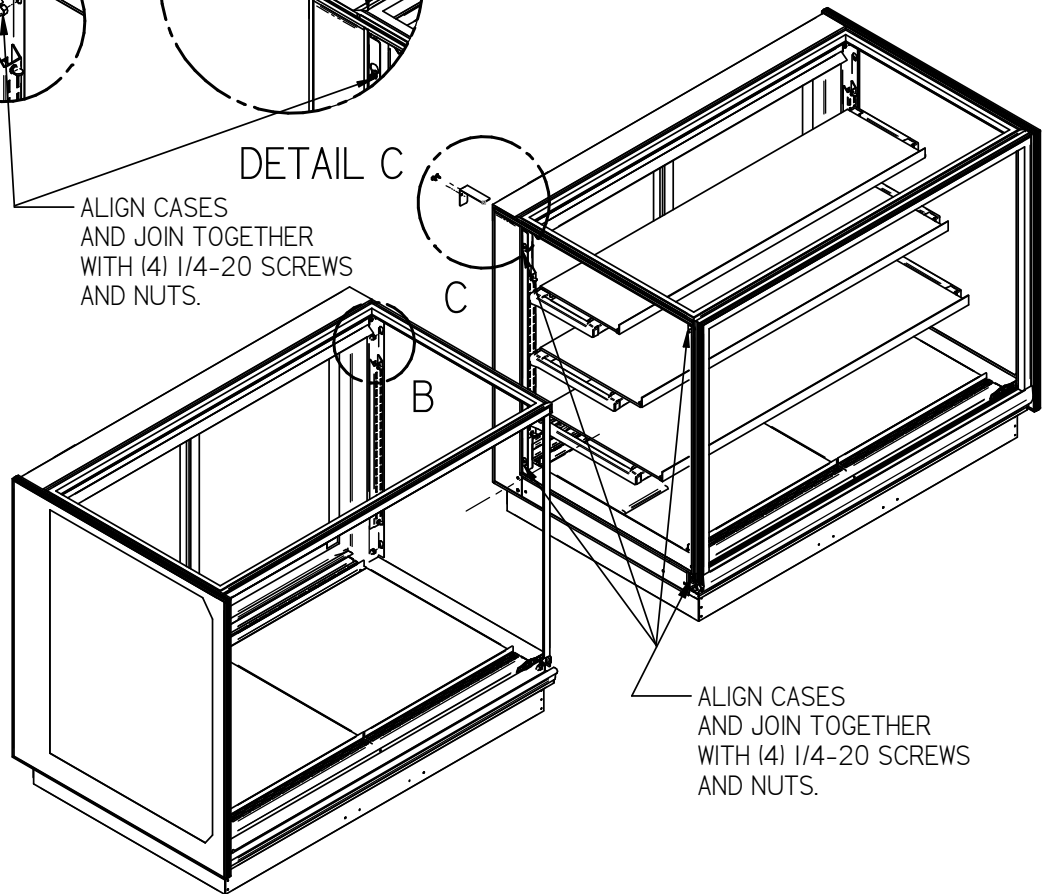

ALIGN CASES AND JOIN TOGETHER WITH (4) 1/4-20 SCREWS AND NUTS.

1. If cases are a Counter Top Models, cut holes in counter top as shown in **Cabinet Preparation** section In this manual.
If cases are a Floor Models, the cases are joined in the same manner but bases will also need to be joined as described in next section.
2. Push cases together and align front and rear of cases.
3. In the holes and slot location shown in above diagram, attach cases together with (4) 1/4-20 screws and nuts provided. If these are Floor Model cases do not tighten screws until completing **The Joining Floor Model Base Section**.
4. Slide the top join strip under the glass trim lip in top rear of case as shown in diagram above.
5. Attach Join Trim Strip with (2) 8-18 self-drilling screws.

Joining Floor Model Bases (No End Panels Between)

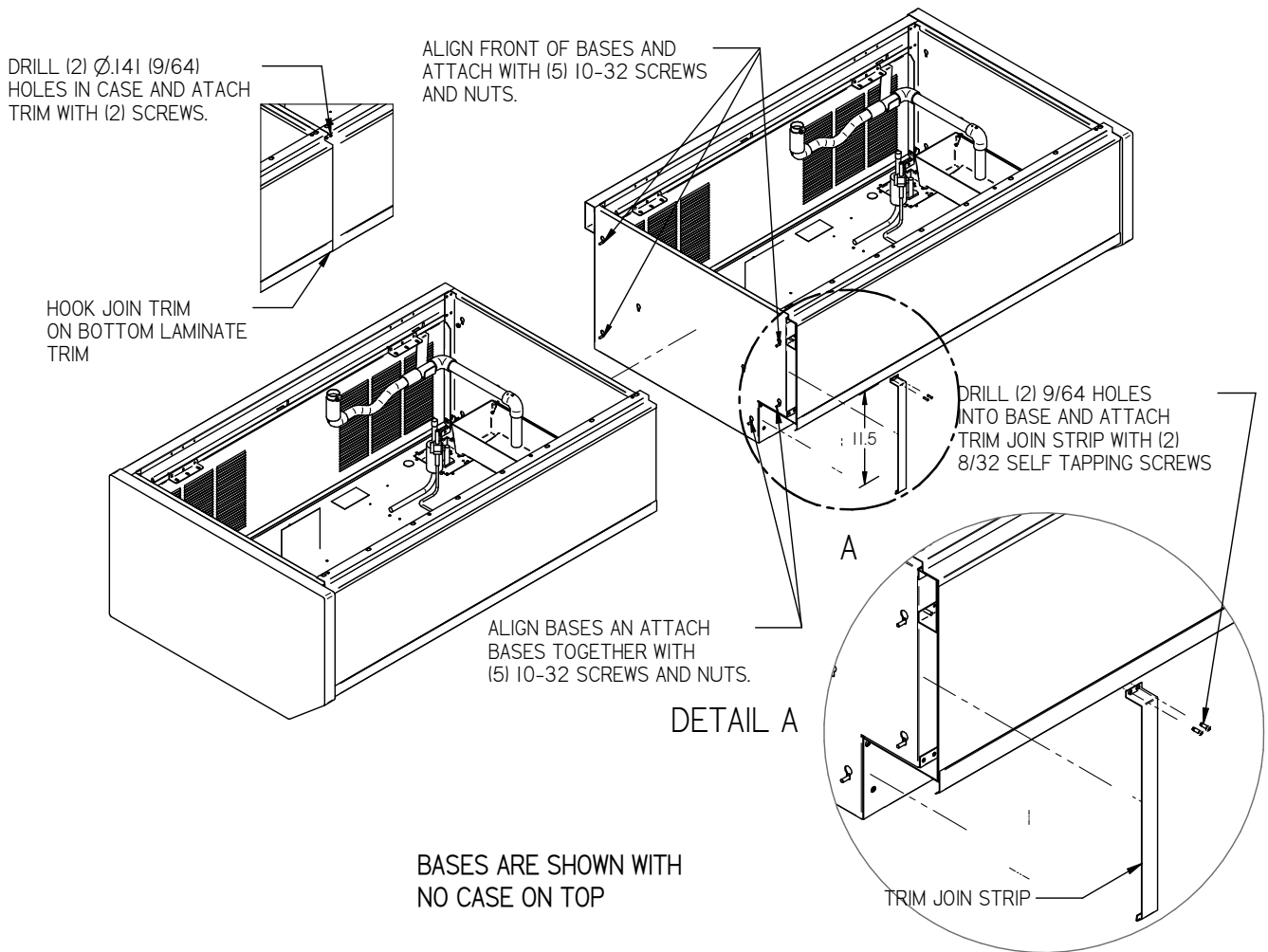

1. The cases are joined in the same manner as described in previous **Joining Cases** section, but the bases will also need to be joined.
2. Push cases together and align front and rear of cases.
3. Remove the base front and back panels as described in **Refrigeration Compartment Panel Removal** Section.
4. Push cases together and align front and rear of cases and bases. If there is a miss-alignment between cases and the bases, it may be necessary to loosen the screws holding the case to the base. The mounting brackets are located inside the top of the base and there are (2) in the front and (2) in the back. This will allow slight adjustment to improve alignment. Retighten these screws once components are properly aligned
5. Attach the cases together using (5) 10-32 screws and nuts provided. Attach in the (5) Key slot location shown in above diagram. There are no fasteners used on the (2) center key slots.
6. Tighten all joining screws and nuts in base and case at this time.
7. Trim the front of base by hooking Base joining trim strip under base valance and up over the top of base trim.
8. Mark the base in the location of the top holes in the base join trim strip. Drill (2) 9/64 holes in base and fasten base join trim strip to base using (2) 8-32 screws provided. Attach Join Trim Strip with (2) 8-32 self-tapping screws.

Joining Cases (Single Glass End Between)

GLASS PANEL IS ATTACHED
TO RIGHT SIDE CASE AT FACTORY

ALIGN CASES AND ATTACH WITH
(4) 1/4-20 X 1/2 SCREWS.

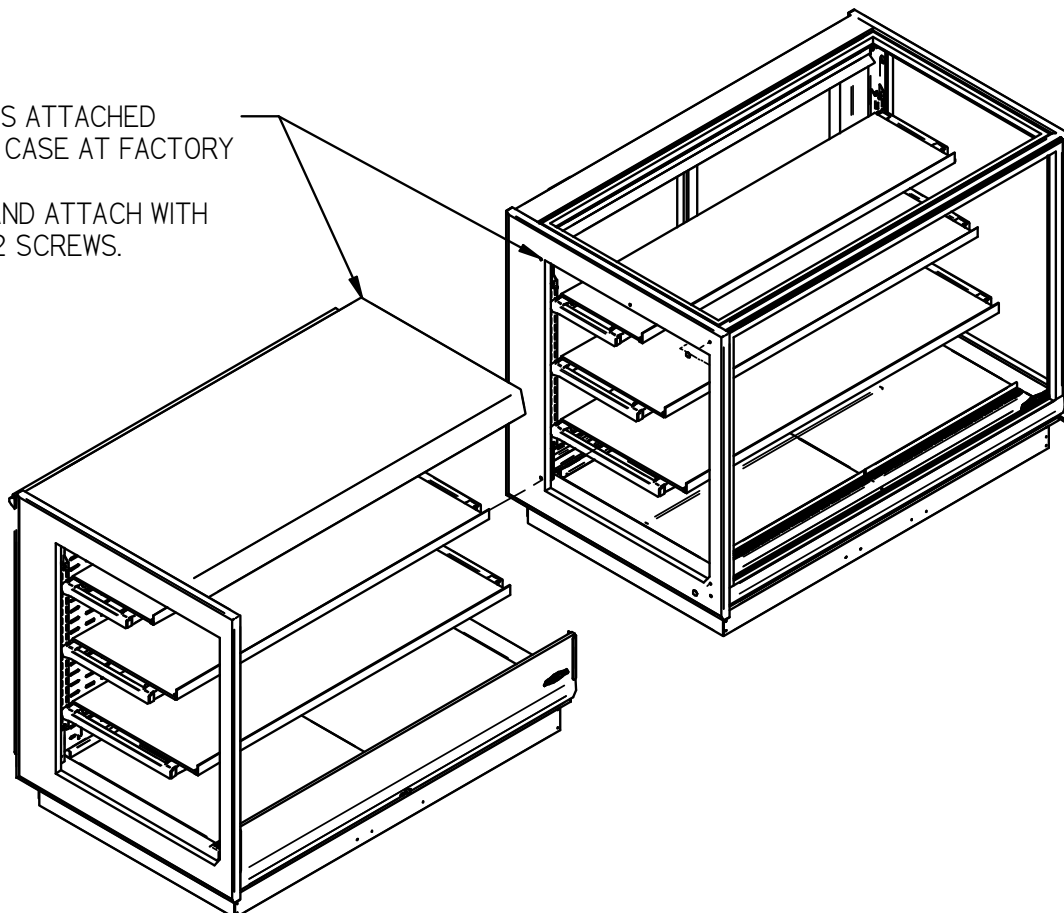

1. If cases are a Counter Top Models, cut holes in counter top as shown in **Cabinet Preparation** section In this manual.
If cases are a Floor Models, the cases are joined in the same manner but bases will also need to be joined as described in next section.
2. Push cases together and align front and rear of cases. Be sure case surfaces are tight together.
3. Attach the cases together with (4) 1/4-20 screws provided. Do not use screws to pull cases together. Glass bushing may strip or glass may break. If these are Floor Model cases do not tighten screws until completing **The Joining Floor Model Base Section**.

Joining Floor Model Bases (Single End Panels Between)

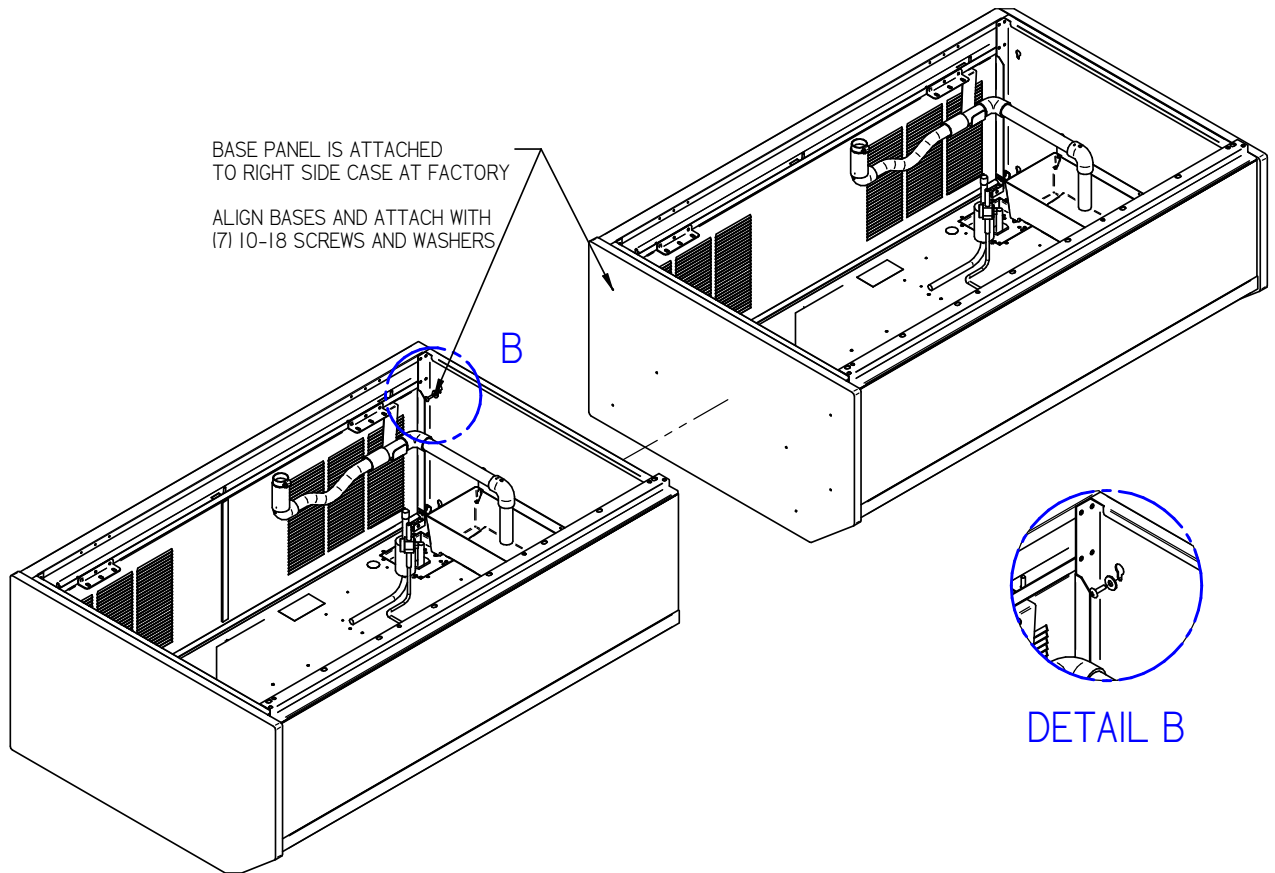

1. cases are joined in the same manner as described in previous Joining Cases section, but the bases will also need to be joined.
2. Push cases together and align front and rear of cases.
3. Push cases together and align front and rear of cases.
4. Remove the base front and back panels as described in **Refrigeration Compartment Panel Removal** Section.
5. Push cases together and align front and rear of cases and bases.
 - If there is a miss-alignment between cases and the bases, it may be necessary to loosen the screws holding the case to the base. The mounting brackets are located inside the top of the base and there are (2) in the front and (2) in the back. This will allow slight adjustment to improve alignment. Retighten these screws once components are properly aligned.
 - It may also be necessary to adjust leg levelers under base until case fronts align and the base side is tight together.
6. Attach the Left case to right case using (7) 10-18 screws and washers provided. NOTE: The bases must be placed tightly together. Do not try to pull cases together with screw or the panel will strip out.

COMPARTMENT PANEL REMOVAL



DANGER: Electric shock hazard. Do not operate unit with panels removed.

Refrigerated Floor Base Models Back Panel (No Back Panel on Non-Refrigerated Models)

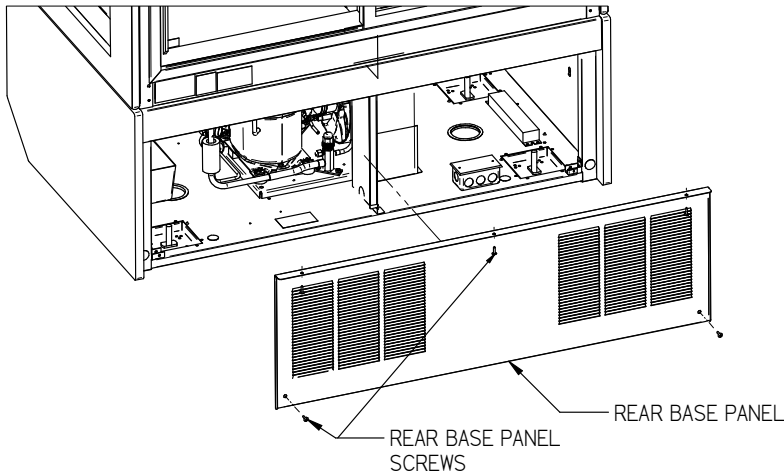

1. Disconnect power to Display Case.
2. Remove Philips head screws located in each lower corner of panel.
3. Remove Philips head screws located on top of panel under the base cross member.
4. Pull top of panel outward until lip on bottom of panel clears bottom of base and remove from case.

Refrigerated and Non-Refrigerated Base Models Front Panel

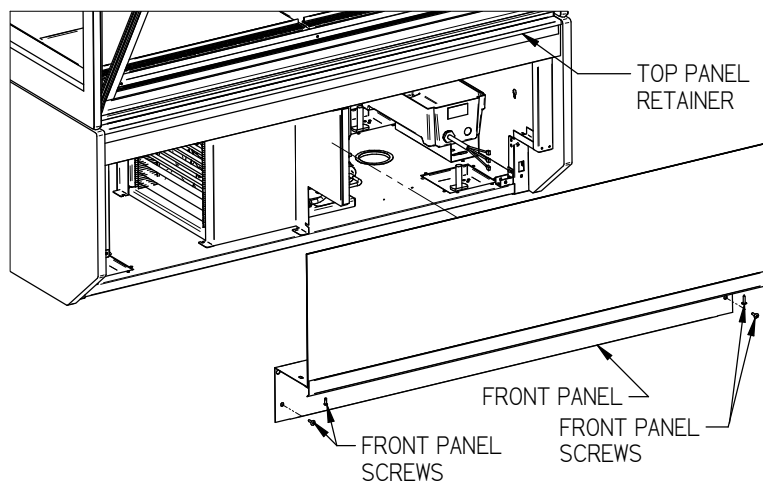

1. Disconnect power to Display Case.
2. Remove (2) front panel phillip head screws from each lower corner of front panel (1) is located on front of panel and the other under the recess behind trim strip. Do not remove the screws holding trip strip to front panel.
3. Slide the front panel down until it slides out of the top panel retainer lip at the top of the panel.
4. Install panel in reverse order.

Refrigerated Counter Models Front and Rear Panels



DANGER: Electric shock hazard. Do not operate unit with panels removed.

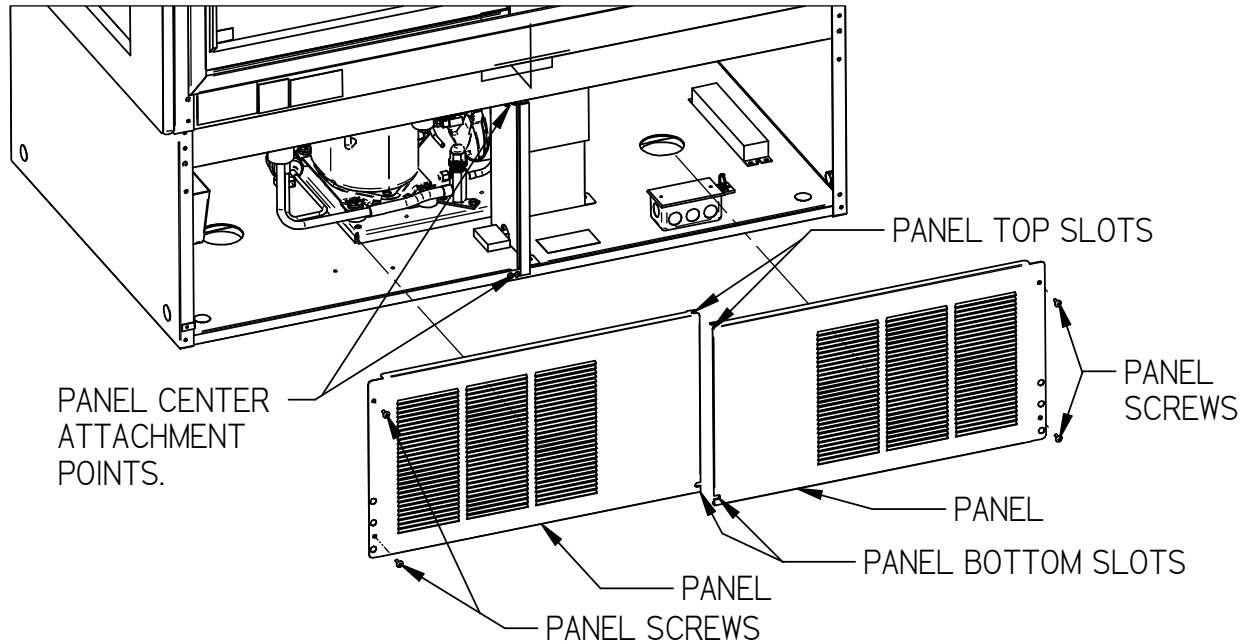

On counter drop in models, the panels are split to allow panel to easily be removed out of swinging cabinet doors that may have a center post.

Also note that unit is shipped with louvered panels on back of case and solid panels on front. This allows air flow for condenser to be in and out of the back of cabinet. These louvered panels can be switched with solid front panels to allow air flow in and out front of cabinet. They can also be mixed with one louver panel in front and one in back to allow front condenser air in or out of front and rear air in or out back. This must be determined before placing unit into counter and cabinet must be prepped to allow desired air flow. See cabinet prep section of this manual. When removing and installing panels be sure panels are reinstalled in correct location to allow condenser air flow.

Note: The front and back panels instructions are identical.

1. Disconnect power to Display Case.
2. Open cabinet door to allow access to condenser compartment.
3. Remove (2) panel screws in outside upper and lower corners of panel.
4. Slide slotted end of panel out of center attachment point and remove from case. Note: Do not remove screws from center attachment point.

NON-Refrigerated Models Top Cover



DANGER: Electric shock hazard. Do not operate unit with panels removed.

There are no components in base on NON-Refrigerated models.
Light Power Supply is located on top of case under the top cover.

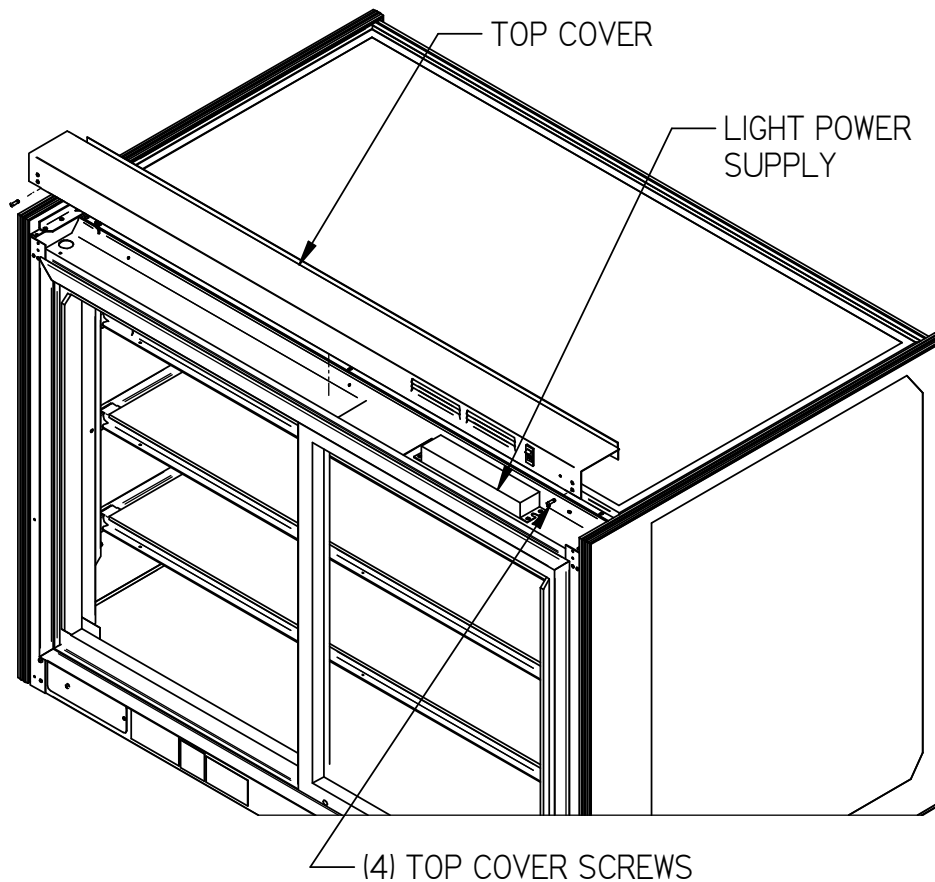

1. Disconnect power to Display Case.
2. Remove the (4) 8-32 top cover screws from top cover.
3. Slide the cover back from under the top glass trim.
Note: there is a ground wire connected from case to the Top Cover
To prevent electrical shock Do Not remove this wire.

END PANEL INSTALLATION

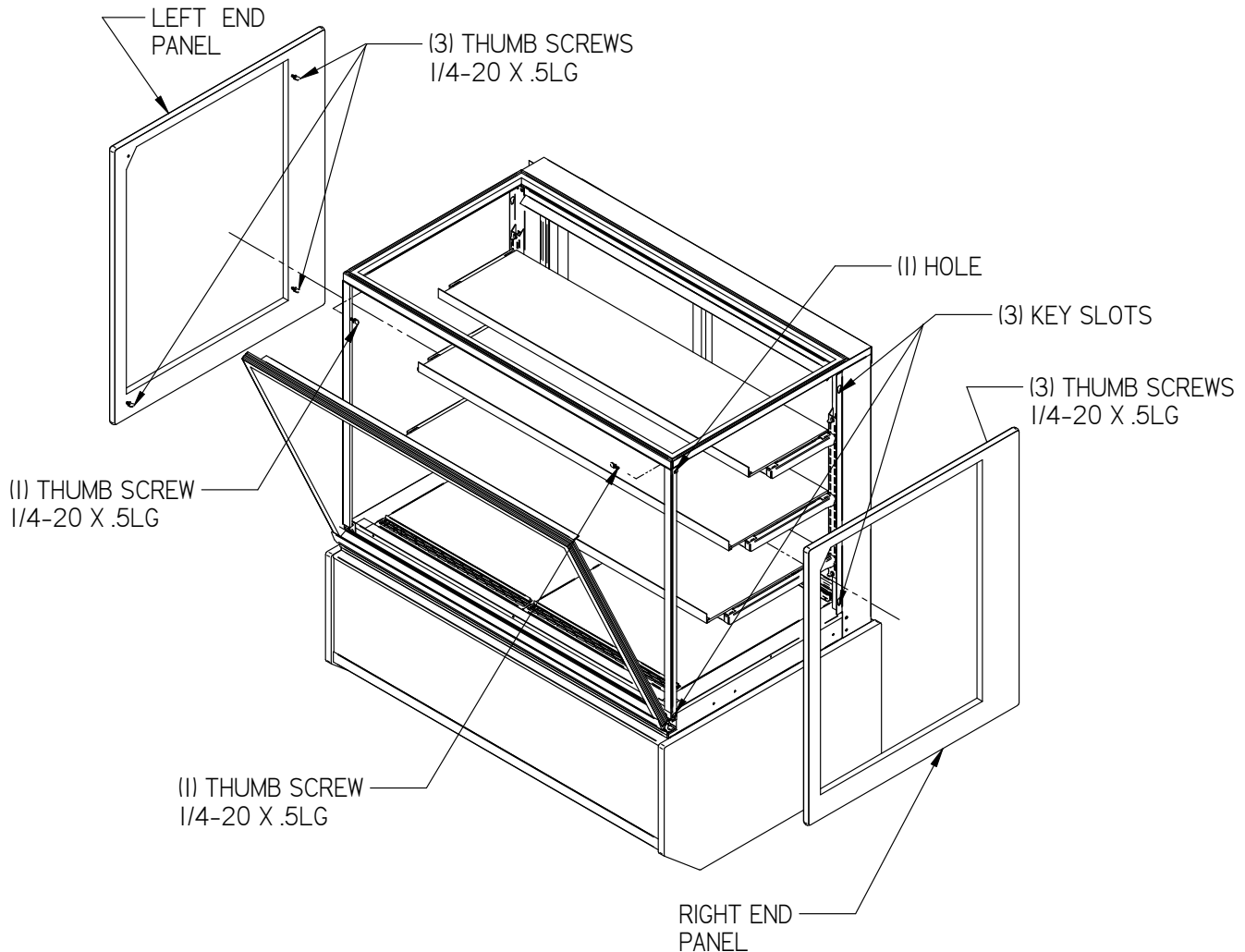

-End Glass is shipped installed on Floor model units.

-End glass is shipped loose on counter drop in units and will need to be installed after unit is placed in to counter and lift handles are removed.

When placing cases in a line up, the number of end panels and end panel type may vary.
See Case Line Up Installation section of this manual.

1. On each side of case there are (3) keyhole mounting slots for easier installation of glass. There is (1) mounting hole in the front top corner of case to prevent glass from accidentally popping off of end of case.
2. Screw (3) thumb screw about half way into end panel in location of the keyholes in case as shown.
3. Align end panel thumb screws with keyholes and hook end panel on to case. Do not tighten thumb screws.
4. Align the mounting hole in top front corner of case with top front hole in end panel and attach with 1/4-20 x .5LG thumb screw
5. Tighten all (4) thumb screws by hand.
6. Remove end panels in reverse order.

SHELVING INSTALLATION & REMOVAL

Shelf Bracket & Supports

NOTE: Different shelf sizes and quantities are optional from factory so shelf bracket quantity and size may vary, but procedure is the same.

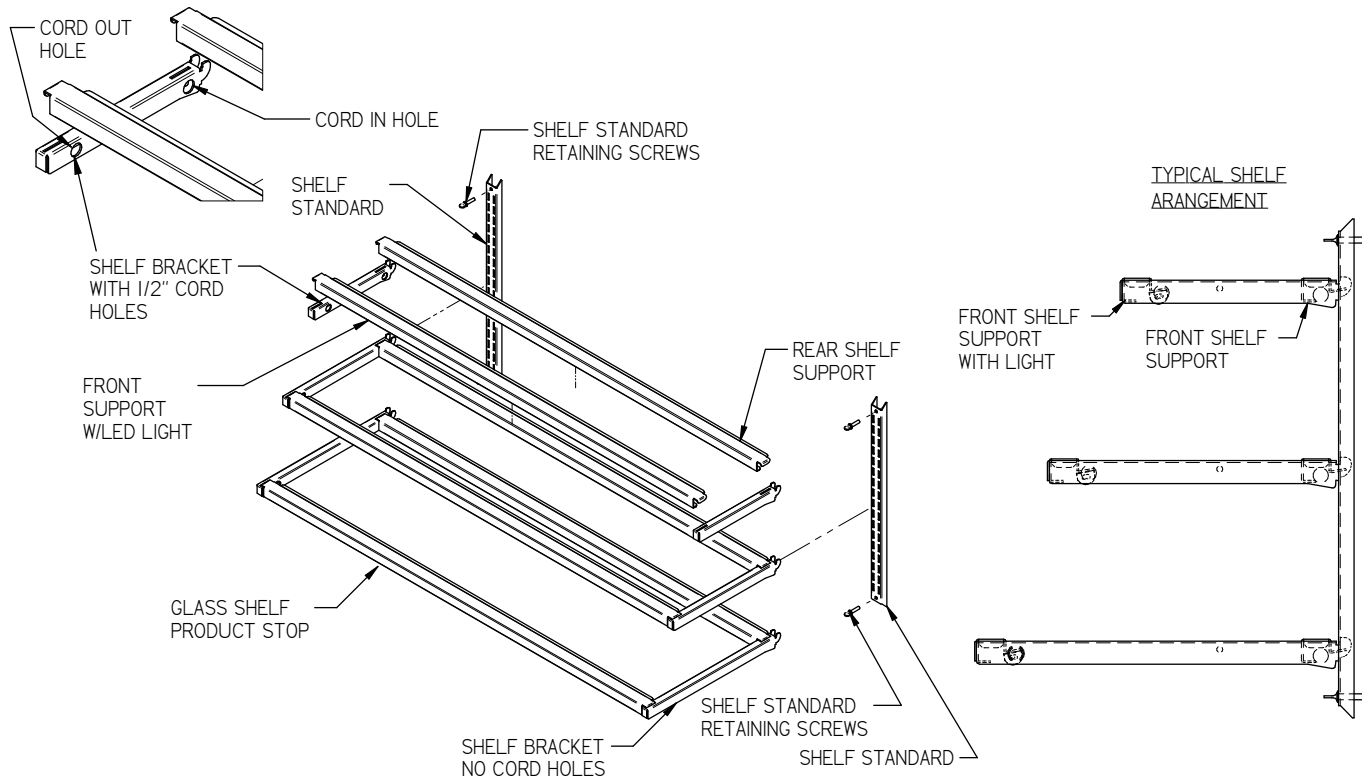

1. Turn the light switch to the off position. Remove rear doors as described in the “Rear Door Removal” section of this manual to allow access to interior of case.
2. Follow the instruction in the illustration below. Starting with the longest brackets for bottom shelf insert (1) of the (2) shelf brackets in the desired shelf standard slot on one side of the case. Place the long second shelf bracket in the same shelf standard slot on the opposite end of case. Important; The bracket with the 1/2 hole must be on the light cord side of case.
3. Repeat procedure for middle shelf brackets and the shortest top brackets. NOTE: Different shelf sizes and quantities are optional from factory so shelf bracket quantity and size may vary, but procedure is the same.
 1. Tilt shelf bracket upward and install shelf bracket hook into desired slot.
 2. Lift shelf bracket hook up behind back of shelf standard and rotate the shelf bracket downward until desired shelf bracket tab rests on front of shelf standard.
 3. Bracket can be either flat 0 degrees 5 degree downward tilt as shown.

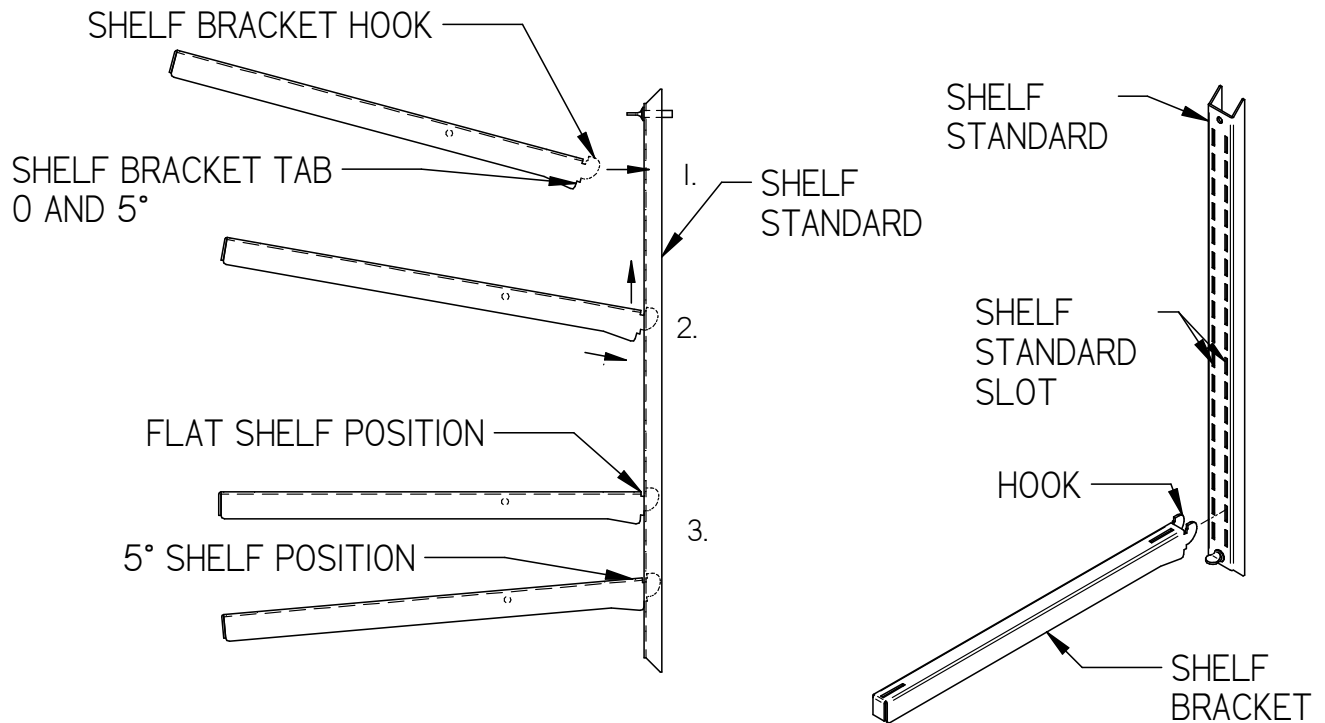

4. Once all shelf brackets are installed in desired position run each shelf light cord into $\frac{1}{2}$ hole in back of shelf bracket and out the $\frac{1}{2}$ " hole in the front of shelf bracket. The shelf light cord length can be adjusted by pulling out cord from cord grommet or pushing cord back into cord grommet.
5. Install front shelf supports with LED lights on to shelf brackets. All shelf supports with the lights are the same. The LED light must be facing towards back of case. Hook shelf support end flanges into front notch of shelf brackets on each side of case.
6. Install rear shelf supports with no lights on to shelf brackets. All shelf supports with no lights are the same. The flange on shelf support should be facing towards back of case. Hook shelf support end flanges into rear notch of shelf brackets on each side of case
7. Push shelf light cords into end of LED light. NOTE: Do not plug cord in backwards. There are (2) humps on end of cord that must align with humps in end of LED light. Plugging in the cord upside down will Damage LED light strip.
8. Manage desired cord lengths by pulling out cord from cord grommet or pushing cord back into cord grommet.

NOTE: Cords always remain in case they are not removable.

Special Length Shelf Installation

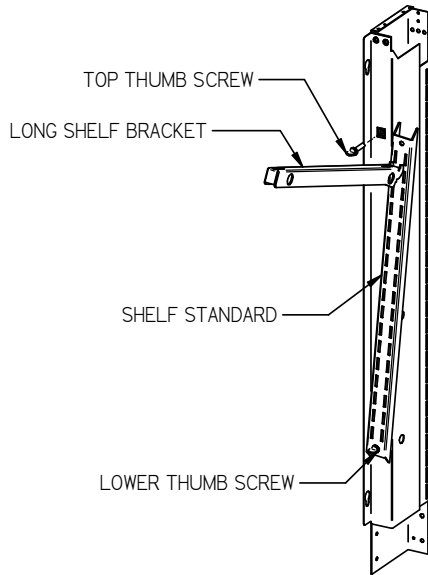

If the top shelf has long brackets and needs to be placed in top shelf standard notch position the shelf bracket may hit top panel or divider panel when trying to install it. If top slot is required install bracket as follows:

1. Remove the shelving from cases.
2. Loosen bottom thumb screw (do not remove)
3. Remove top thumb screw
4. Rotate the shelf standard towards center of case until the shelf bracket can be slipped into slots of standard.
5. Once shelf bracket is in place, rotate the shelf standard back to vertical position and reinstall top thumb screw and tighten.
6. Tighten lower thumb screw and install shelving as described in shelving installation.

LED Light Plug Connection

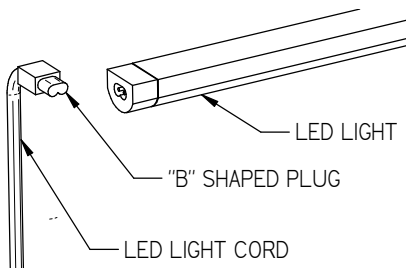

NOTICE: The plug must be inserted in correct orientation into LED light. LED light will not light if Connecting plug into LED light upside down. It may also cause LED light failure.

Look at the end of the plug and the receptacle of LED light. On one side of the LED plug there are two bumps and the other side there is a flat. (Similar to the letter B shape). The LED light has the same configuration. The shapes must align correctly when inserting LED plug into the LED light.

Glass Shelves

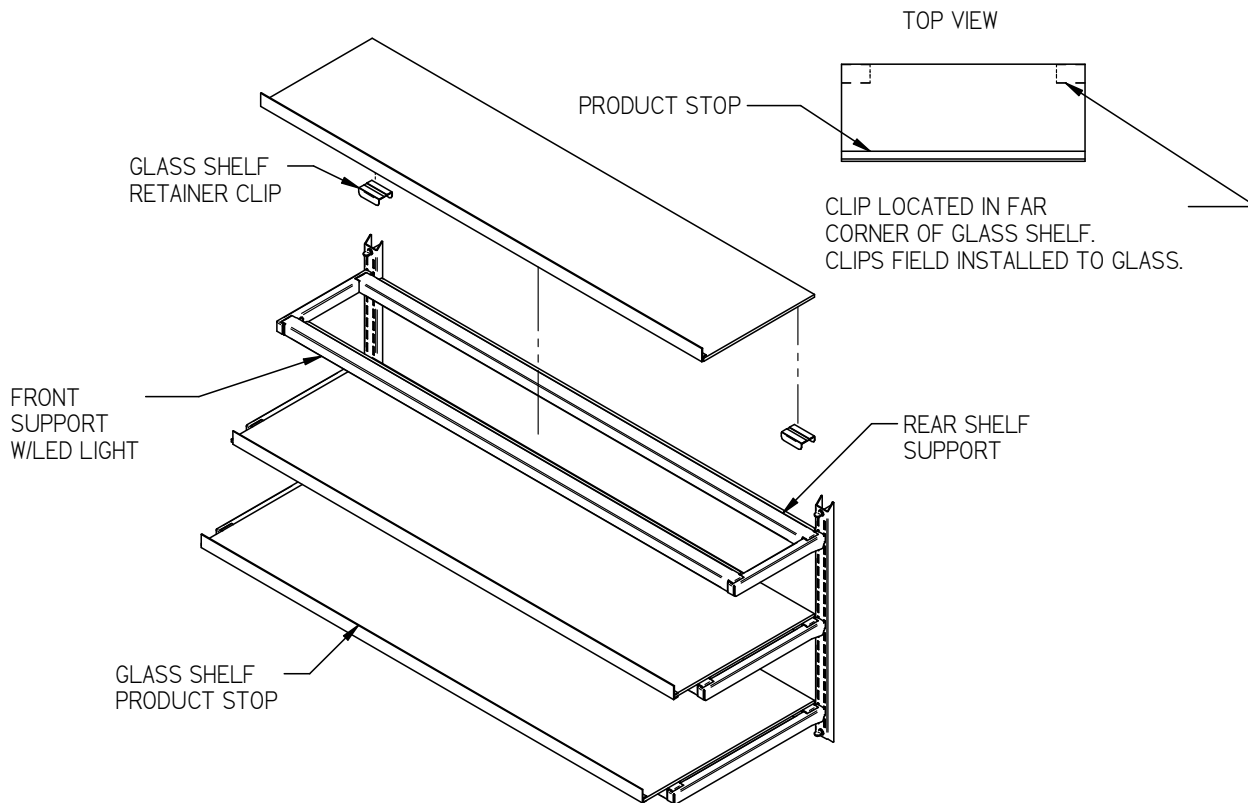

1. For first time installation attach (2) glass shelf retainer clips to each glass shelf in location shown in illustration. Clean area of glass where glass shelf holder is to be located with rubbing alcohol and let air dry before installing shelf glass holder. Remove backing from tape located on flat side of glass shelf holder. Position the glass shelf holders in the (2) far corners of glass. Repeat for each glass shelf.
2. Place front of glass
3. Set each glass shelf on to the shelf supports so that the glass shelf retainer clip straddles the rear support. The top glass should be the narrowest glass and the bottom glass shelf should be the widest.

Horizontal Dual Zone Shelf Divider Installation

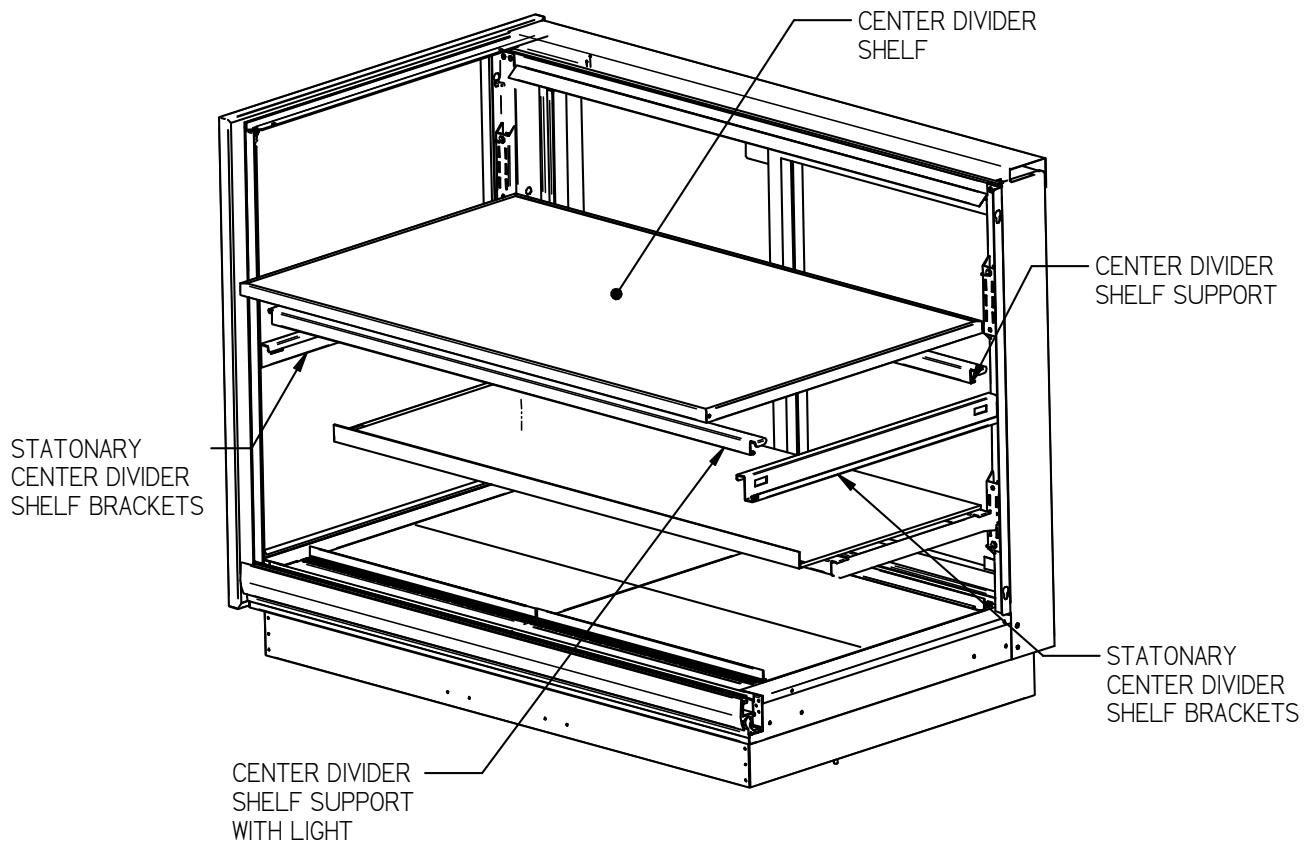

Horizontal Dual Zone option has a stationary center shelf that divides upper and lower section. This allows the upper section to be about 15 degrees warmer then the lower section.

The center divider brackets are stationary and are mounted in case from the factory.

The 34" tall unit has a shelf above and below the center divider and the 26" tall unit only has a shelf below the center divider. Install these shelves as outlined in the shelving installation section of this manual.

Install both shelf supports by hooking the shelf support into the notches on the center divider shelf brackets. The shelf support with light should be on the front with light facing into case.

The center divider shelf can be installed through the front of case by opening the front glass or through the back of case by removing both doors. Place it across the shelf supports and push towards the doors until it hits the stops located on the back of the shelf brackets.

FRONT AND REAR DOORS REMOVAL

ITR, ITD, ITDSS, AND ITDSSF Models (Front Doors ITDSS Only)

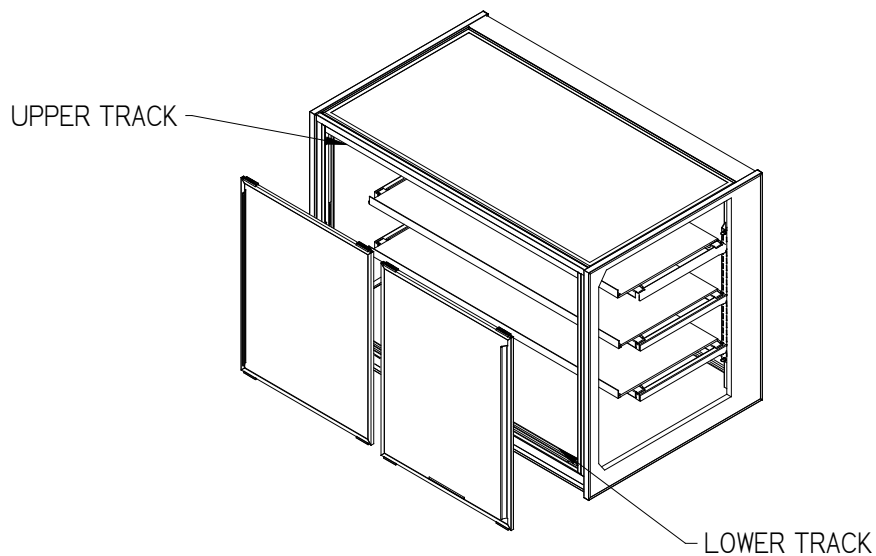
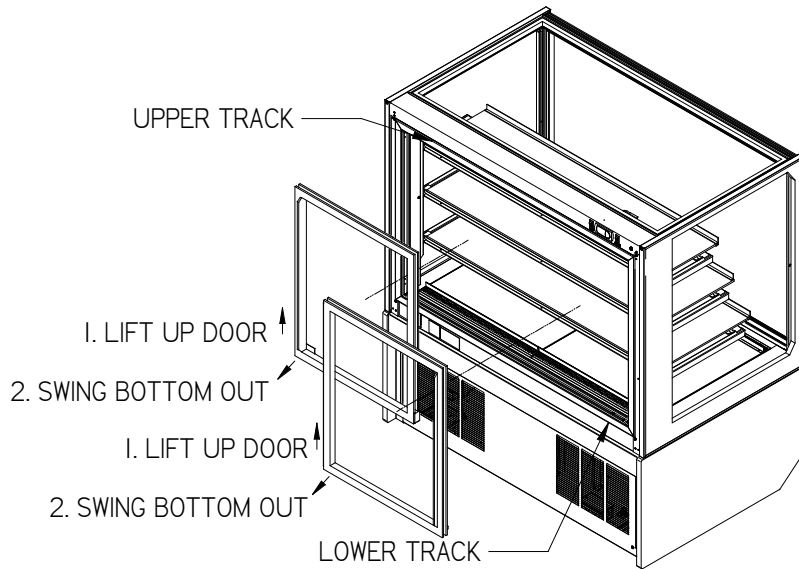

1. Start with the outer door and lift the door upward until the bottom edge of door clears the lower track and then swing the bottom of the door outward and down out of upper track.
2. After the outer door is removed repeat the procedure for the inner door.
3. Reverse this procedure for door reinstallation. Rear doors are not interchangeable.

ITRSS Models

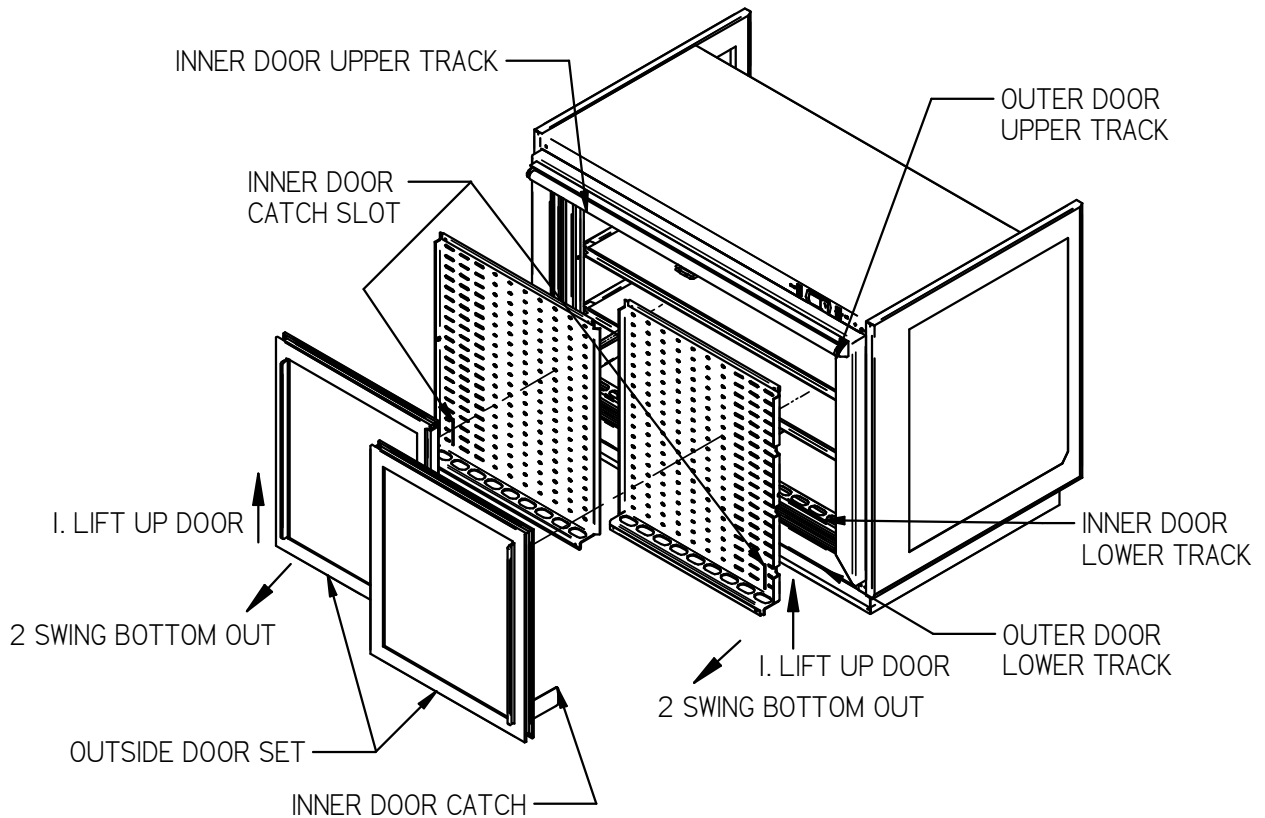

1. Start with the outer outside door and lift the door upward until the bottom edge of door clears the lower track and then swing the bottom of the door outward and down out of upper track.
2. Remove the outer inside door using the same procedure.
3. The inner door set can then be removed using the same procedure starting with the inner outside door followed by the inner inside door.
4. Reverse this procedure for door reinstallation starting with the inner inside door followed by the inner outside door. Check that the doors slide freely.
5. Replace the outside inner door and the outside outer door. Be sure to slide the inner door catch into the inner door catch slot for each door.

Note: None of the doors are not interchangeable and they must be replaced in the same location that they were removed from.

SECURITY NIGHT COVER (OPTION)

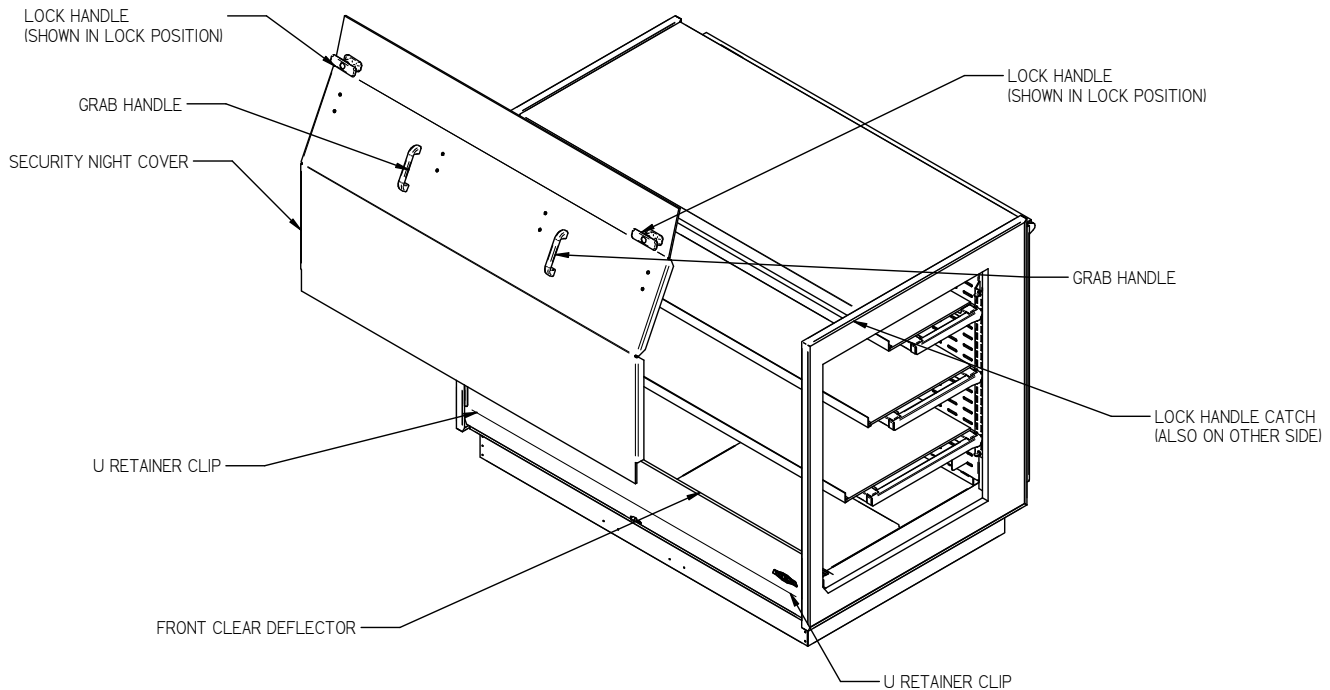

Removal:

1. Unlock the lock handles and turn handles to the vertical position to disengage from lock handle catches.
2. Grasp the front grab handles and lift the cover straight up and out of the case opening.

Installation:

1. Turn the lock handle so the latch handle is vertical to the top of the case.
2. Holding the grab handles place the bottom flange of the security night cover inside the "U" retainer clips located on each side of case opening behind the front clear deflector. There also may be a "U" retainer clip in the center of the case that must also engage the security night cover flange.
3. Set the top flange of the security cover down against the top glass handle.
4. Turn the lock handles so they engage the lock handle catches and use the key to lock them in place.

IMPORTANT: Cleaning the Acrylic plastic security night cover require special care to prevent hazing of material. Lightly dust (not wipe) the surface with clean soft cloth. Then the surface can be wiped carefully with a soft, wet cloth or chamois. The cloth or chamois must be kept free of grit by frequently rinsing in clean water. Grease and oil can be removed with kerosene. Do not use window cleaners or kitchen scouring compounds. DO NOT use solvents such as Acetone, Benzene, Carbon Tetrachloride, and Lacquer Thinners. A spray wax such as Pledge or Maguire's polish can be applied and wiped with a clean soft cloth. The wax tends to fill in and hide small scratches.

OPERATING INSTRUCTIONS

Control Description



NOTICE: This refrigerated display case is designed to operate in a maximum environment of 80 DEG. F and 55% relative humidity. Exceeding these limits will cause poor case performance and sweating of glass panels.

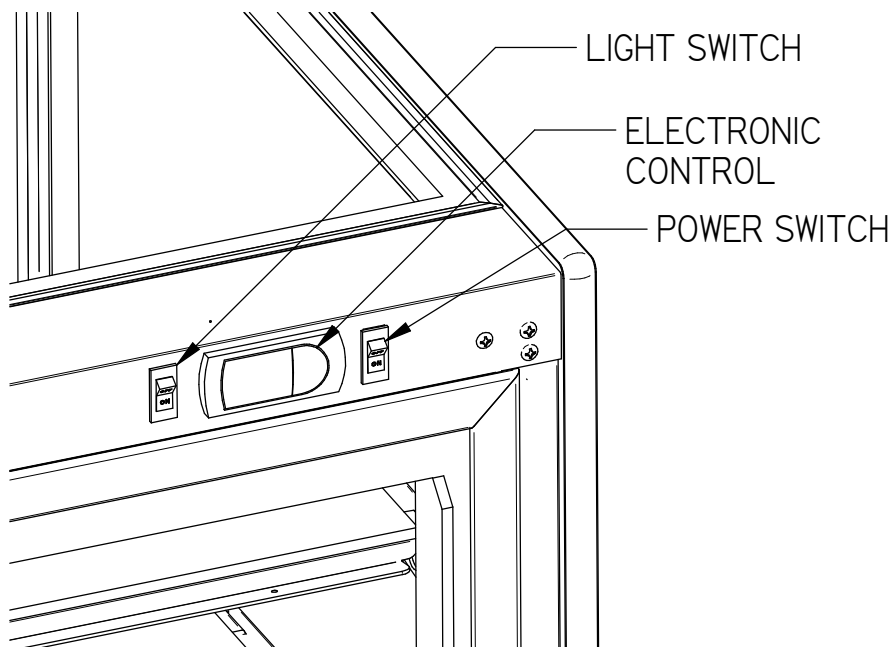

Power Switch (Refrigerated Models Only)

The unit has a power switch that turns off power to the entire unit, including the condensate evaporator and the lights.

Light Switch (All Models)



The unit has a light switch that turns on and off the interior lights of unit.

Electronic Temperature Control (Refrigerated Models Only)

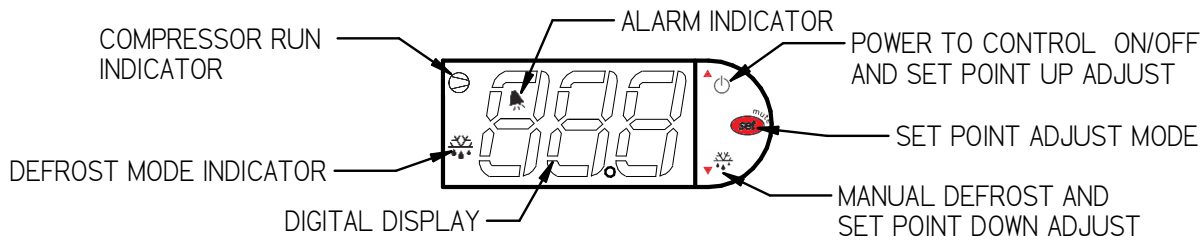

The temperature control allows the user to adjust the temperature of the display merchandiser to their needs. When not in adjustment mode the read out shows relative interior case temperature.





Button Overview

	<p>Press and hold this button for 3 seconds to turn system on (if off) or off (if on). Also used to adjust set point when in set point adjust mode</p>
	<p>Press to enter set point adjust mode, confirm set point changes, and mute alarms.</p>
	<p>Press and hold this button for 3 seconds to initiate a manual defrost (and cancel defrost if initiated), also adjusts set point down when in set point adjust mode</p>



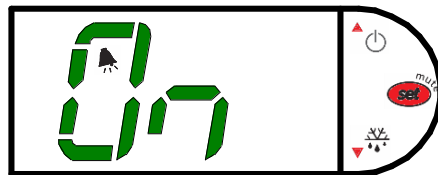

Powering on control

To turn refrigeration control power on, press and hold  for approx. five seconds. The display will read “On” while the button is depressed. When the control powers on, the display will read the relative current case temperature (on initial startup it will show room temperature). The compressor run indicator  will illuminate on the display, meaning that the compressor is running. (Note: the control may already be in the on mode when shipped from factory).

To turn refrigeration control power to off, press and hold  for approx. five seconds. The display will read “Off” while the button is depressed. When the control powers off the display will flash back and forth between the relative current case temperature and “Off”. The compressor run indicator  will be off on the display. When refrigeration control is in the off-mode cabinet lights and evaporator fans will still operate, but the compressor will not turn on causing the case to gradually reach room temperature. **(NOTE: Cases supplied with optional fan control unit will turn on and off both the compressor and the evaporator fans when control is turned on and off).**







Adjusting the set point

The set point is what determines how cold the display case will hold food and beverage. To adjust the set point press and hold the  button approx. 5 seconds until the display begins to flash a number. Then press the use the  button to scroll number up (colder) or press the  button to scroll number lower (warmer). There are nine (9) available set point numbers, the higher the number of the set point, the colder the display case will run, with setting “9” being the coldest and setting “1” being the warmest. Once you have chosen your desired setting press the  button again to confirm your choice.



Entering manual defrost mode

In order to initiate a manual, defrost press and hold the  button approx. 5 seconds. The control will read “dEF” while the button is being held. The defrost is initiated when the defrost mode indicator  illuminates on the display. The control display will then return to reading the case temperature. When the defrost mode indicator  turns off the defrost is complete and the compressor will turn back on illuminating the compressor run indicator .



Error codes

It is possible for error codes to be displayed on the control screen. In the event of a malfunction an alarm will sound and the alarm indicator  will be displayed on the display. An error code or codes will flash intermittently on the display. If there are multiple codes, the display will continuously cycle through them. The following photo shows error code “E0” as an example.



Mute: You may mute the alarm by pressing and releasing the wrench button. The red ringing bell and all error codes will still be displayed. When the fault is remedied the control will return to normal operation and will automatically clear the codes from the display.

Error codes may be encountered if either the controller or the display case is malfunctioning. The following is a list of error codes that may be encountered.

Table 1 - Error Codes and Resolutions

Code	Description	Cause	Resolution
E0	Temperature probe error	Probe signal is interrupted or short-circuited	<ol style="list-style-type: none"> 1. Check to ensure probe wires and quick disconnect are secure in control. 2. Check probe resistance to table below. If 0 resistance is present check wiring insulation. If infinite resistance is present check for breaks in wiring (meter will likely read overload or very high in the mega-ohm range). 3. Ensure that probes are wired per the wiring diagram provided. 4. Replace probe if other remedies fail, or if probe resistance deviates from “Error! Reference source not found.” Error! Reference source not found.
E1	Defrost probe error	See E0	
EE	Unit parameter reading error	Operating conditions	<ol style="list-style-type: none"> 1. Remedy abnormal operating conditions. The control is rated to operate in a range of 14 to 122°F (-10 to 50°C) and less than 90%RH non-condensing. 2. Replace control if problem persists.
EF	Operating parameter reading error	See EE	

Table 2 - Temperature Probe Common Resistance Chart

Probe Temp	Maximum Resistance [Ω]	Normal Resistance [Ω]	Minimum Resistance [Ω]
32°F (0°C)	27.83	27.28	26.74
77°F (25°C)	10.1	10	9.9
212°F (100°C)	1	0.97	0.94

ELECTRONIC CONTROL OPERATION (Refrigerated Models Only)

This unit is equipped with an electronic temperature control. The control parameters are set at the factory and cannot be manually changed in the field. The preset control parameters are listed on the chart in the Settings Chart below.

Operation

The control uses two sensors, one located in the air stream and one located on the evaporator coil. The sensor located in the air stream is referred to as the temperature control sensor. The sensor located on the evaporator coil is referred to as the defrost probe.

The temperature control sensor is located on the plastic tub behind the evaporator coil to the left in the cold air stream. The sensor location is critical for proper operation on the unit. Do not move or relocate this sensor.

The coil sensor is strapped to the evaporator coil. This sensor location is critical for proper operation of the unit. Do not move or relocate this sensor.

The temperature control is set to cut in at 39°F (3.9°C). The Temp control cuts out at 26°F (-3.3°C) at the coldest setting “9” and 36°F (2.2°C) at the warmest setting “1”.

Defrost Cycle

The control is programmed to initiate defrost via two different methods. There are 3 programmed defrost cycles in the case which will initiate a defrost cycle every 8 hours. The unit does not have a time clock so the defrost cycles cannot be set for any specific time of day.

The unit also has an ‘On demand’ defrost feature that will initiate a defrost when the temperature differential between the evaporator temperature and the air temperature is more than 20°F (11.1°C) for 5 minutes after 30 minutes into the refrigeration cycle (e.g. if the air stream probe measures 42°F/5.6°C or greater and the defrost probe measures 20°F/-6.7°C or lower for five minutes). Once initiated the defrost cycle will terminate when evaporator coil sensor reaches 43°F (6.1°C).

If a manual defrost is required, one can be initiated by pressing and holding the down arrow for three (3) seconds. This is typically unnecessary and should only be performed if special circumstances require it.

Control Parameters

Table 3 - Control Parameters

Parameter Description □	Control Setpoint →	1	2	3	4	5	6	7	8	9
Compressor Cut in [°F]		38.0								
Compressor Cut out [°F]		32.0	31.0	30.0	29.0	28.0	27.0	26.0	25.0	24.0
Compressor Min On Time		2 min								
Compressor Min Off Time		2 min								
Compressor Max Run Time		60 min								
Defrost Termination Temp [°F]		43.0								
Time to first defrost		8 hr								
Time to subsequent defrost		8 hr								
Defrost duration		30 min								
Defrost on demand differential [°F]		18.0								
Delay for defrost on demand		5 min								
Time delay to the next defrost on demand		30 min								

Initial Startup

After all the checks outlined in the installation section of this manual have been made, the case is ready to be put into service. Turn on the Power at the breaker box and flip the Power Switch and Light Switch on unit to the on position. Also ensure that the control is powered on as described above.

(Refrigerated Models Only)

At start up from a warm unit, it is recommended that the temperature control is set to a mid-setting, such as 5. After the unit has gone through several cycles, adjust the control to a warmer or a colder setting if necessary to maintain desired product temperature. Allow refrigerated models to run for at least two hours before placing pre-chilled product into display area.

Placing Product into Case

After completing shelving installation as outlined in “Shelving Installation and Removal” section of this manual you may begin placing product into the display case.

- Do not exceed 100 pounds of weight per shelf. Heavy product should be distributed evenly across the entire shelving area.
- Determine desired shelving location and angle before placing product in case. Product must be removed to readjust shelf location and angle.

(Refrigerated Models)

- Do not overhang the front shelves with product. Product may overhang rear of shelf, but allow a minimum of 1-1/2” between product and rear door. Improper clearance in front and rear of shelf will block the refrigerated airflow and could cause product loss.
- Do not block the slots along the front or rear of the case display pan. Covering these slots will block the refrigerated airflow and could cause product loss.
- The display pan is removable for cleaning and can become dislodged in shipment. To ensure proper airflow and performance of the case, make sure that the display pan is pushed completely down into evaporation tub. Check that the pan is installed properly before placing product the display pans.

-CASE SHOULD BE STOCKED WITH PRE-CHILLED PRODUCT ONLY.

ATTENTION:

- This Federal refrigerated display case is designed to operate in a maximum environment of 75 DEG. F and 55% relative humidity. Exceeding these limits could cause poor case performance and sweating of glass panels.

MAINTENANCE

Cleaning Condenser Coil (All Self Contained Refrigerated Models)



NOTICE:

Condenser coil must be cleaned a minimum of twice per month to insure proper refrigeration performance and prevent compressor failure. In some environments, it may be necessary to clean more frequently. **FAILURE TO CLEAN CONDENSER COIL WILL VOID COMPRESSOR WARRANTY.**

FLOOR BASE ITR MODEL

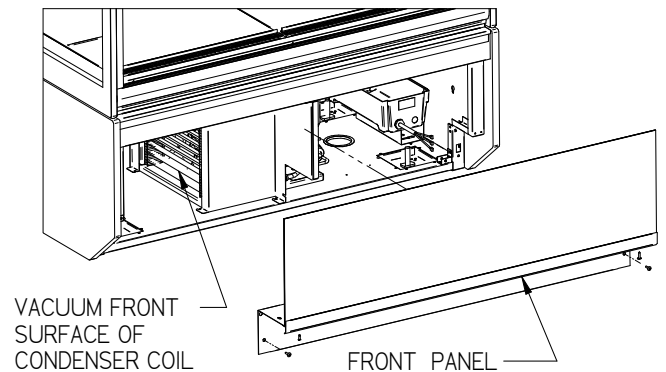
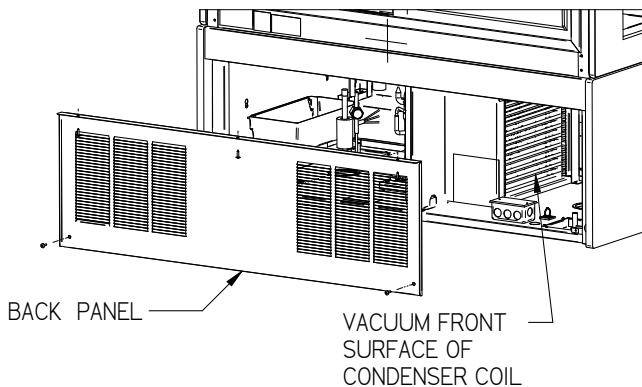

COUNTER ITR MODEL

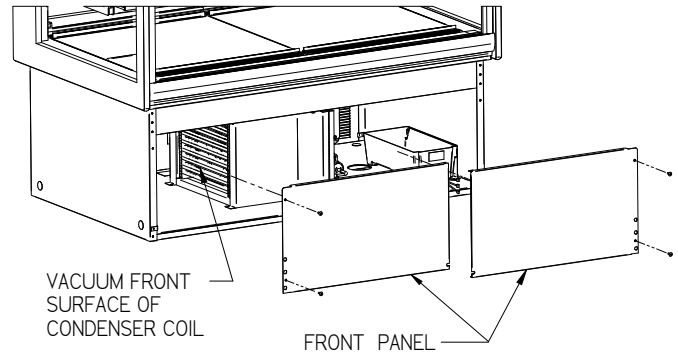
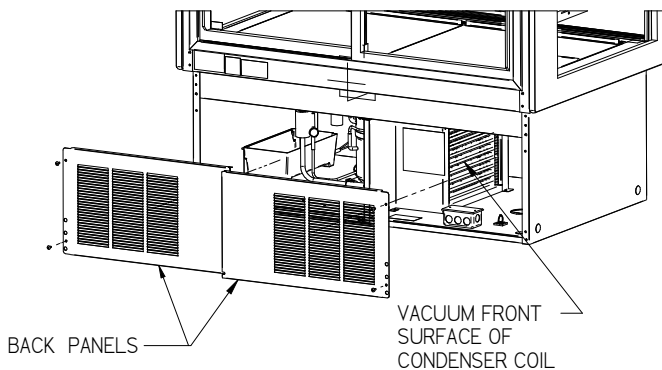

It is very important that the Condenser coil is cleaned monthly to insure proper refrigeration performance and to prevent compressor failure. Failure to clean condenser coil will void condenser warranty.

The condenser can be cleaned from either the front or the back of case depending on which is more accessible.

1. Disconnect power to the unit.
2. Remove the back or front panels located on the base or condenser compartment of unit. See Panel Removal section of this manual.
3. Carefully vacuum the front surface of condenser coil. Take care not to bend coil fins with vacuum cleaner nozzle.
4. Reinstall all panel and retaining screws and reconnect power.

Top LED Light Replacement

1. Turn power switch and light switch to off position.
2. Unplug 24v DC power wire from end of existing LED light strip.
3. Snap existing LED strip out of retaining clips.
4. Snap the new LED light strip into retainer clips
5. Reattach the 24v DC power wire into end of the new LED light strip. NOTE: Do not plug cord in backwards. There are (2) humps on end of cord that must align with humps in end of LED light. Plugging in the cord upside down will Damage LED light strip.
6. Turn power switch and light switch to on position.

Shelf LED Light Replacement

1. Turn power switch and light switch to off position.
2. Remove Shelf from display case.
3. Unplug 24v DC power wire from end of existing LED light strip.
4. Remove the shelf support with light from case.
5. Use a putty knife between the LED and the shelf support to cut the double-sided adhesive holding LED light strip to case. Clean as much adhesive off of shelf support as possible.
6. Attach new LED light strip to shelf support using double sided adhesive.
7. Reinstall shelf support and shelf into case.
8. Reattach the 24v DC power wire into end of the new LED light strip. NOTE: Do not plug cord in backwards. There are (2) humps on end of cord that must align with humps in end of LED light. Plugging in the cord upside down will Damage LED light strip.
9. Turn power switch and light switch to on position.

CLEANING INSTRUCTIONS

Daily Cleaning

The case should be cleaned thoroughly, as described in the weekly cleaning section, before it is used for the first time.



NOTICE: Avoid splashing or soaking any electrical components with water to prevent electrical damage to the case.



NOTICE: Shut off lights and power switches and remove all product from case. Allow sufficient time for the unit to reach room temperature before proceeding with cleaning.



NOTICE: Remove all product from case before proceeding with cleaning procedure.



NOTICE: Acrylic front air deflector, plastic inner doors, and lift up doors requires special washing procedures to prevent hazing and yellowing of material.



NOTICE: This case is not designed to be cleaned by flushing.

ITR, ITD, ITDSS and ITDSSF Models

Note: For major spills or foreign material buildup use complete weekly cleaning instructions.

Note: Detergents are not recommended and do not use abrasive cleaners or pads to prevent scratching of surfaces.

1. Clean all foreign materials from the door opening.
2. Wipe complete interior areas of case using a damp cloth.
3. To allow easier access to clean interior tilt the front glass forward. Tilt the front glass out by grabbing the top edge of glass with finger tips and pulling it away from magnetic strips on case. Tilt glass until it stops at about 30 degrees angle. **IMPORTANT:** Hold on to the glass until it stops and do not let it free fall. Allowing glass may damage glass or hinge. The glass can then be cleaned with common window cleaners. **IMPORTANT:** Do not allow glass cleaner to contact any of the Acrylic front deflector, front lift-up doors, and plastic inner doors.
4. The remaining exterior surface should be wiped down using any ammoniated cleaners or soapy warm water.
5. **IMPORTANT:** Cleaning the Acrylic plastic front deflector, front lift-up doors, and plastic inner doors require special care to prevent hazing and yellowing of material. Lightly dust (not wipe) surface with clean soft cloth. Then the surface can be wiped carefully with a soft, wet cloth or chamois. The cloth or chamois must be kept free of grit by frequently rinsing in clean water. Grease and oil can be removed with kerosene. Do not use window cleaners or kitchen scouring compounds. **DO NOT** use solvents such as Acetone, Benzene, Carbon Tetrachloride, and Lacquer Thinners. A spray wax such as Pledge or Maguire's polish can be applied and wiped with a clean soft cloth. The wax tends to fill in and hide small scratches.

Weekly Cleaning ITR, ITD, ITDSS AND ITDSSF Models

This procedure is recommended on a weekly basis. It may need to be performed more often if necessary to maintain a clean, sanitary case. The case should be cleaned to this procedure before using the first time.



NOTICE: Avoid splashing or soaking any electrical components with water to prevent electrical damage to the case.



NOTICE: Shut off lights and power switches and remove all product from case. Allow sufficient time for the unit to reach room temperature before proceeding with cleaning.



NOTICE: Remove all product from case before proceeding with cleaning procedure.



NOTICE: Acrylic front air deflector, plastic inner doors, and lift up doors requires special washing procedures to prevent hazing and yellowing of material.



NOTICE: This case is not designed to be cleaned by flushing.

Note: For major spills or foreign material buildup perform the weekly cleaning instructions.

ITR & ITD Models

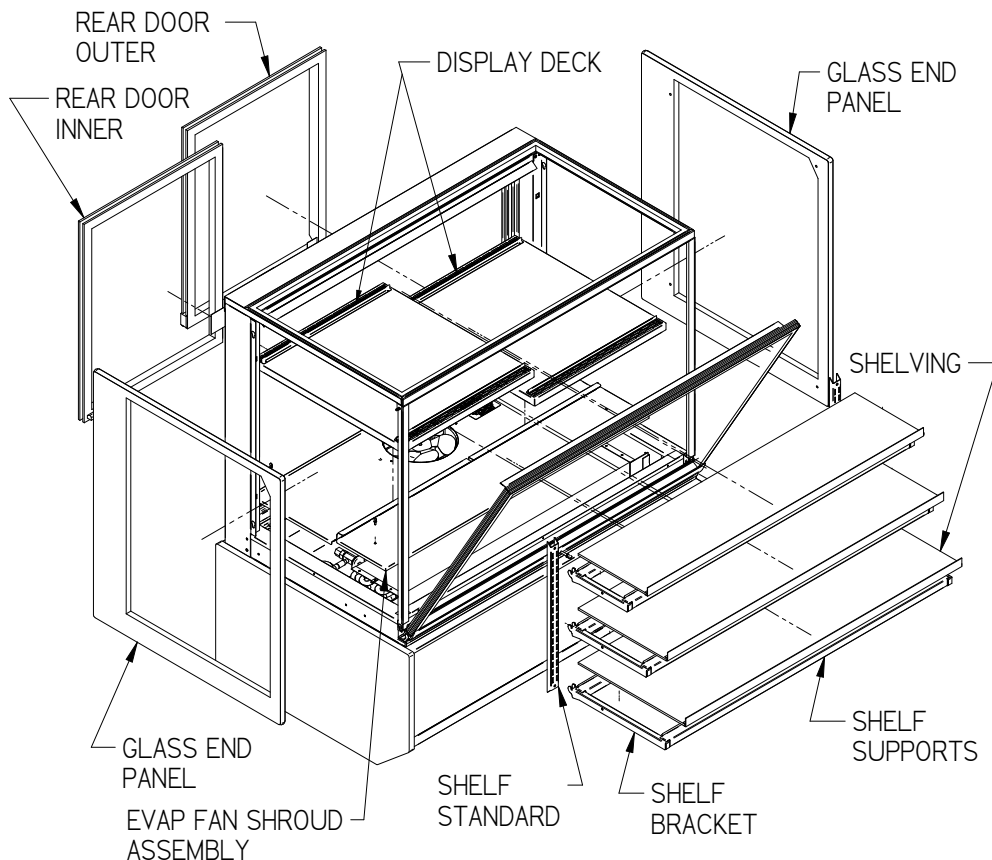

6. Disconnect power to display case.
7. Remove the rear doors as described in rear door removal section
8. Remove all interior shelving as described in the shelving installation and removal section of this manual.
9. Remove both shelf standards from interior of case by removing thumb screws located at top and bottom of shelf standard.
10. Remove end glass as described in end panel removal section of this manual.

(Step 6 & 7 Refrigerated Models Only)

11. Lift the Display Deck(s) up and out of evaporator tub and remove from case.
12. Remove the evaporator fan shroud by removing the thumbscrews along the backside of evaporator fan shroud and the (2) thumb screws on each side of evaporator coil. Unplug fan(s) from wire harness and remove evaporator fan shroud with fan attached from case.
13. Clean the entire interior of the case using warm soapy water. Wipe off all soapy water with a damp cloth and allow to dry.
14. Clean all shelves, shelf support bars, shelf standards, shelf brackets, and display deck using warm soapy water and a brush. Rinse thoroughly and allow to dry.
15. Clean behind front glass hinge using warm soapy water and sweeping debris to each end and
16. Clean all foreign material from inner and outer rear door tracks using warm soapy water and a brush. Apply a light film of lubricant such as PAM to make the doors operate smoother.
17. Clean both sides of the doors, end glass and front glass using any common window cleaner. **IMPORTANT:** Do not allow glass cleaner to contact any of the Acrylic front deflector, front lift-up doors, and plastic inner doors. The front glass can be tilted forward to allow easier access to clean interior. Tilt the front glass out by grabbing the top edge of glass with finger tips and pulling it away from magnetic strips on case. Tilt glass until it stops at about 30 degrees angle. **IMPORTANT:** Hold on to the glass until it stops and do not let it free fall or damage to glass or hinge may occur. Close the glass by pushing glass back up against magnetic gasket in closed position.
18. **IMPORTANT:** Cleaning the Acrylic plastic front deflector, front lift-up doors, and plastic inner doors require special care to prevent hazing and yellowing of material. Lightly dust (not wipe) surface with clean soft cloth. Then the surface can be wiped carefully with a soft, wet cloth or chamois. The cloth or chamois must be kept free of grit by frequently rinsing in clean water. Grease and oil can be removed with kerosene. Do not use window cleaners or kitchen scouring compounds. **DO NOT** use solvents such as Acetone, Benzene, Carbon Tetrachloride, and Lacquer Thinners. A spray wax such as Pledge or Maguire's polish can be applied and wiped with a clean soft cloth. The wax tends to fill in and hide small scratches.
19. Reassemble the case in reverse order.

Weekly Cleaning ITRSS Models

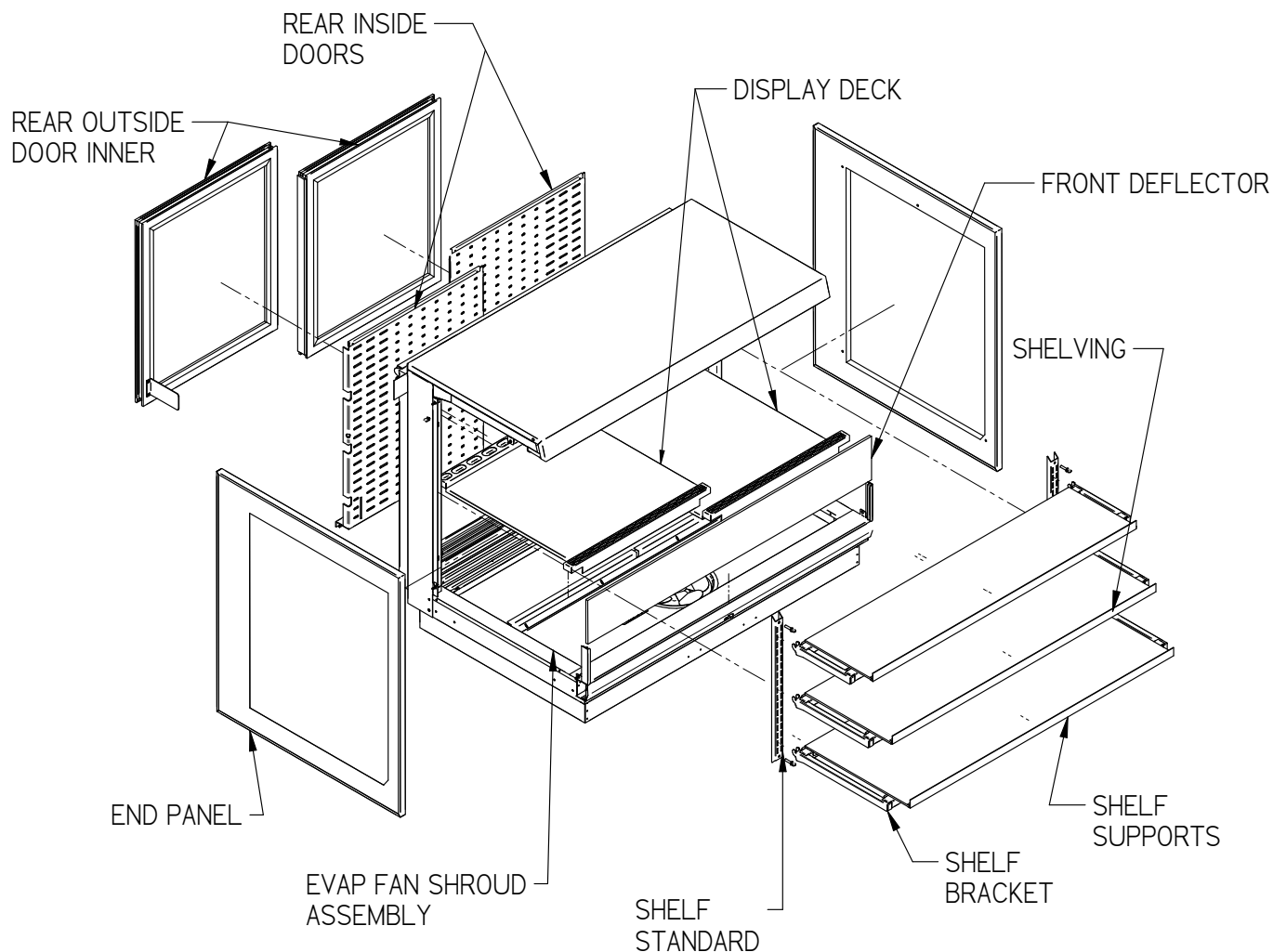

1. Disconnect power to display case.
2. Remove the outer and inner rear doors as described in rear door removal section
3. Remove the front deflector by lifting it up and out of retainer channel.
4. Remove all interior shelving as described in the shelving installation and removal section of this manual.
5. Remove both shelf standards from interior of case by removing thumb screws located at top and bottom of shelf standard.
6. Remove end panels as described in end panel removal section of this manual.
7. Lift the Display Deck(s) up and out of evaporator tub and remove from case.

8. Remove the evaporator fan shroud by removing the thumbscrews along the backside of evaporator fan shroud and the (2) thumb screws on each side of evaporator coil. Unplug fan(s) from wire harness and remove evaporator fan shroud with fan attached from case.
9. Clean the entire interior of the case using warm soapy water. Wipe off all soapy water with a damp cloth and allow to dry.
10. Clean all shelves, shelf support bars, shelf standards, shelf brackets, and display deck using warm soapy water and a brush. Rinse thoroughly and allow to dry.
11. Clean behind front glass hinge using warm soapy water and sweeping debris to each end and
12. Clean all foreign material from inner and outer rear door tracks using warm soapy water and a brush. Apply a light film of lubricant such as PAM to make the doors operate smoother.
13. Clean both sides of the doors, end glass and front glass using any common window cleaner.
IMPORTANT: Do not allow glass cleaner to contact any of the Acrylic front deflector, front lift-up doors, and plastic inner doors. The front glass can be tilted forward to allow easier access to clean interior. Tilt the front glass out by grabbing the top edge of glass with finger tips and pulling it away from magnetic strips on case. Tilt glass until it stops at about 30 degrees angle.
IMPORTANT: Hold on to the glass until it stops and do not let it free fall or damage to glass or hinge may occur. Close the glass by pushing glass back up against magnetic gasket in closed position.
14. **IMPORTANT:** Cleaning the Acrylic plastic front deflector, front lift-up doors, and plastic inner doors require special care to prevent hazing and yellowing of material. Lightly dust (not wipe) surface with clean soft cloth. Then the surface can be wiped carefully with a soft, wet cloth or chamois. The cloth or chamois must be kept free of grit by frequently rinsing in clean water. Grease and oil can be removed with kerosene. Do not use window cleaners or kitchen scouring compounds. **DO NOT** use solvents such as Acetone, Benzene, Carbon Tetrachloride, and Lacquer Thinners. A spray wax such as Pledge or Maguire's polish can be applied and wiped with a clean soft cloth. The wax tends to fill in and hide small scratches.
15. Reassemble the case in reverse order.

Weekly Exterior Cleaning All

1. Clean the front, end glass and rear doors using any common window cleaner. **IMPORTANT:** Do not allow glass cleaner to contact any of the Acrylic front deflector, front lift-up doors, and plastic inner doors.
2. The exterior surfaces should be wiped down using any ammoniated cleansers or warm soapy water.
3. Clean the Acrylic plastic front deflector requires special care to prevent hazing and yellowing of material. Lightly dust (not wipe) surface with clean soft cloth. Then the surface can be wiped carefully with a soft, wet cloth or chamois. The cloth or chamois must be kept free of grit by frequently rinsing in clean water. Grease and oil can be removed with kerosene. Do not use window cleaners or kitchen scouring compounds. **DO NOT** use solvents such as Acetone, Benzene, Carbon Tetrachloride, and Lacquer Thinners. A spray wax such as Pledge or Maguire's polish can be applied and wiped with a clean soft cloth. The wax tends to fill in and hide small scratches

SERVICE

Service Information

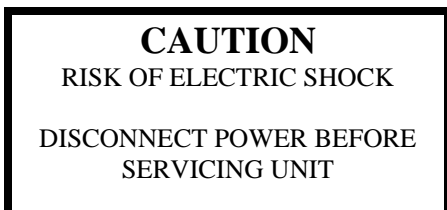

Before any service work is performed on the case, make sure all power is disconnected to the case.

To find a service company in your area, please visit our website at www.federalindustries.com. There you can also find self-service tools to help you get the answers you need faster!

For Warranty Service Requests & ALL Technical Support please contact:

- Phone: (800) 356-4206 and choose the Tech Support/Warranty Option
- Email: Service@federalind.com

For Warranty Compressors please contact the Parts Department:

- Phone: (800) 356-4206 and choose the Warranty Parts Option
- Email: Parts@Federalind.com



Federal Industries has partnered with Parts Town for ALL Non-Warranty Part Identification, Pricing, Lead Times, Orders & Freight Quotes. Please contact Parts Town directly if you need parts:

- Website: PartsTown.com
- Email: CustomerService@PartsTown.com
- Phone: 833-809-8188

Special Service Situations

There are rare occasions when the refrigerant charge must be evacuated from a case in order to perform service work. In those situations, Federal Industries recommends that the refrigerant charge be evacuated into a recovery system to prevent the possibility of hydrofluorocarbons (HFC's) from being released into the atmosphere.

If moisture or liquid is observed around or under a Federal Industries case, an immediate investigation should be made by qualified personnel to determine the source of the moisture or liquid. The investigation made should determine if the case is malfunctioning or if there is a simple housekeeping problem.



NOTICE:

Moisture or liquid around or under a case is a potential slip/fall hazard for persons walking by or working in the general area of the case. Any case malfunction or housekeeping problem that creates a slip/fall hazard around or under a case should be corrected immediately.

Pre-Service Checklist

You may avoid the cost and inconvenience of an unnecessary service call by first reviewing this checklist of frequently encountered situations that can cause unsatisfactory case performance.



CAUTION: Before servicing case turn off power at the main breaker or fuse box.

Case Does Not Operate

- Check for disconnected power supply.
- Check for tripped breaker or blown fuse.
- Check that power switch is on.

Lights Do Not Operate

- Check that light switch is on.
- Be sure light cord is properly seated into LED light strip.
- Is the light cord plugged in to light strip upside down.

Case Temperature Too Warm

- Check that the cold air inlet and outlet slots are not blocked.
- Be sure that the rear doors are closed and tightly sealed.
- Check for a blocked or dirty condenser coil fins.
- Check cold airflow. Lack of adequate cold airflow could be a defective evaporator fan or blocked evaporator coil. Check that paper or foreign material is not blocking evaporator. If the evaporator coil is blocked due to excessive frost, initiate a manual defrost on the electronic temperature control as described in the Using Electronic Temperature Control section of this manual.
- Is the case installed properly to allow adequate air flow to and from condenser?
- Check that the electronic control settings are correct.
- Check environment conditions. This case is designed to operate in no more than 80 degree 55 percent humidity.

SALE & DISPOSAL

Owner Responsibility

If you sell or give away your Federal Industries case you must make sure that all safety labels and the Installation-Service Manual are included with it. If you need replacement labels or manuals, Federal Industries will provide them free of charge. Contact the customer service department at Federal Industries at (800) 356-4206.

The customer service department at Federal Industries should be contacted at the time of sale or disposal of your case so records may be kept of its new location.

If you sell or give away your Federal Industries case and you evacuate the refrigerant charge before shipment. Federal Industries recommends that the charge be evacuated into a recovery system to prevent the possibility of HFC's from being released into the atmosphere.

MAIN WIRING DIAGRAMS

Non-Refrigerated

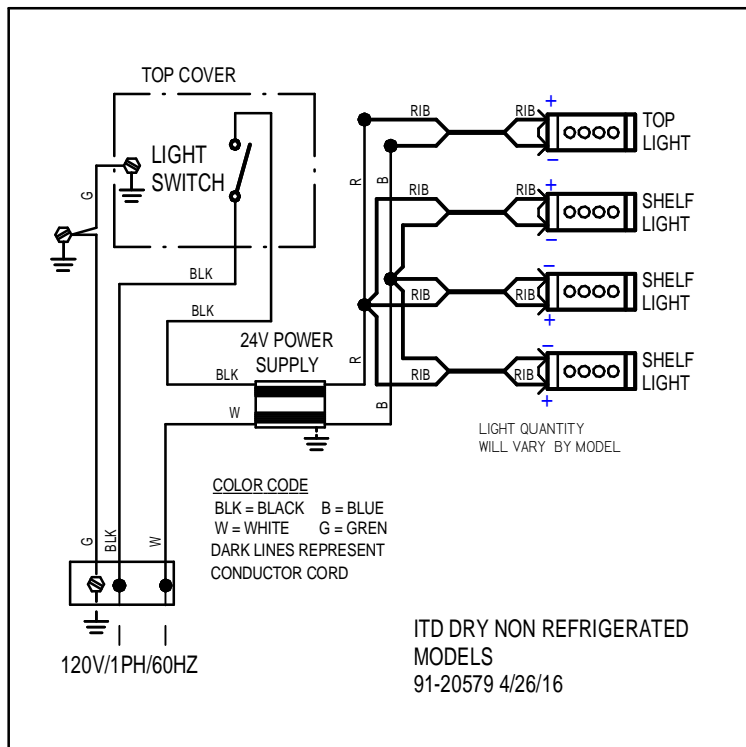

Fan Control Option, Refrigerated Self Contained (not available ITRSS models)

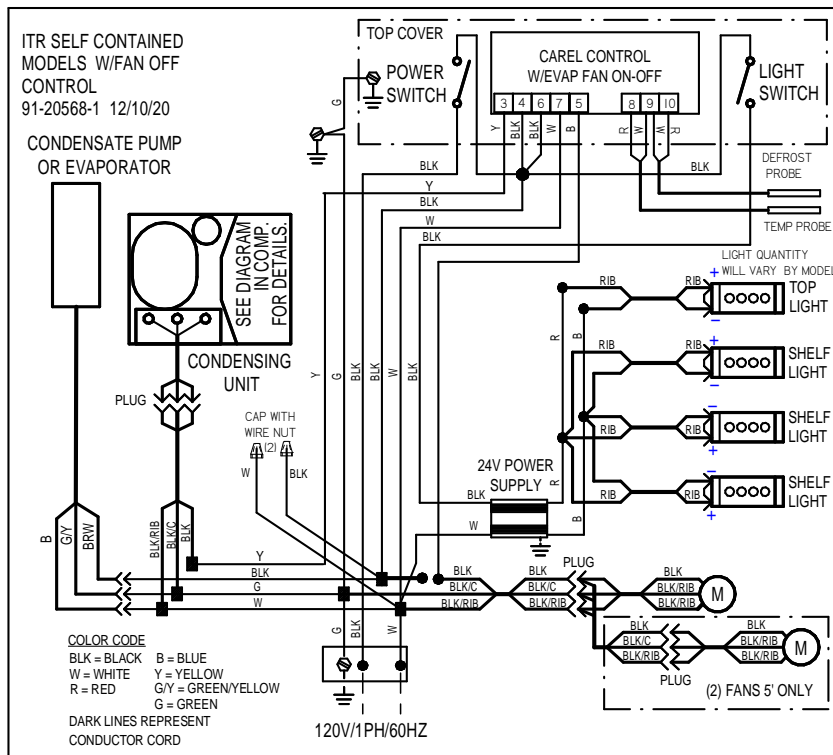

All Refrigerated Self Contained (except ITRSS6026, ITRSS6034) (Before 12/1/19)

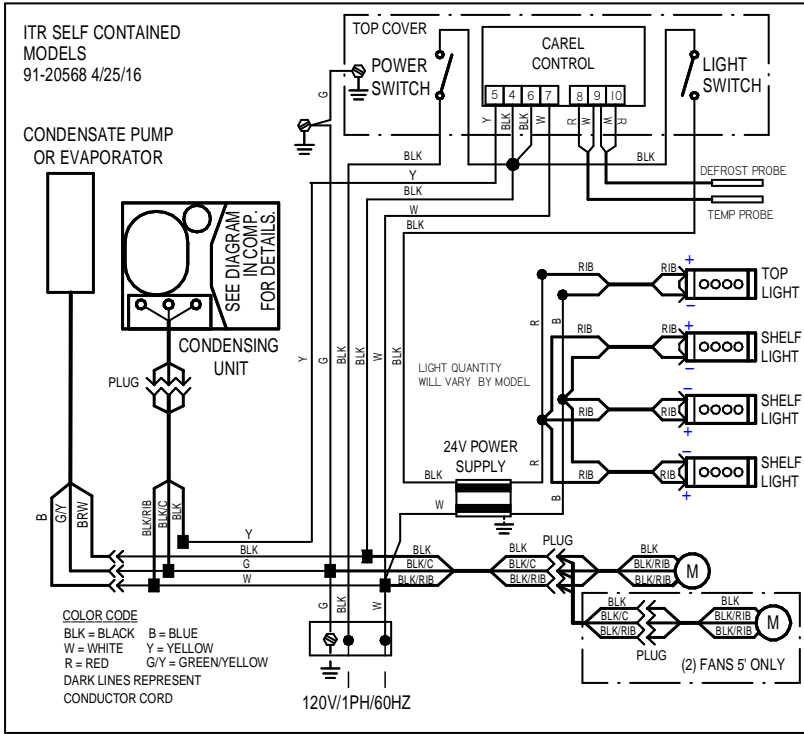

All Refrigerated Self Contained (except ITRSS6026, ITRSS6034) (After 12/1/19)

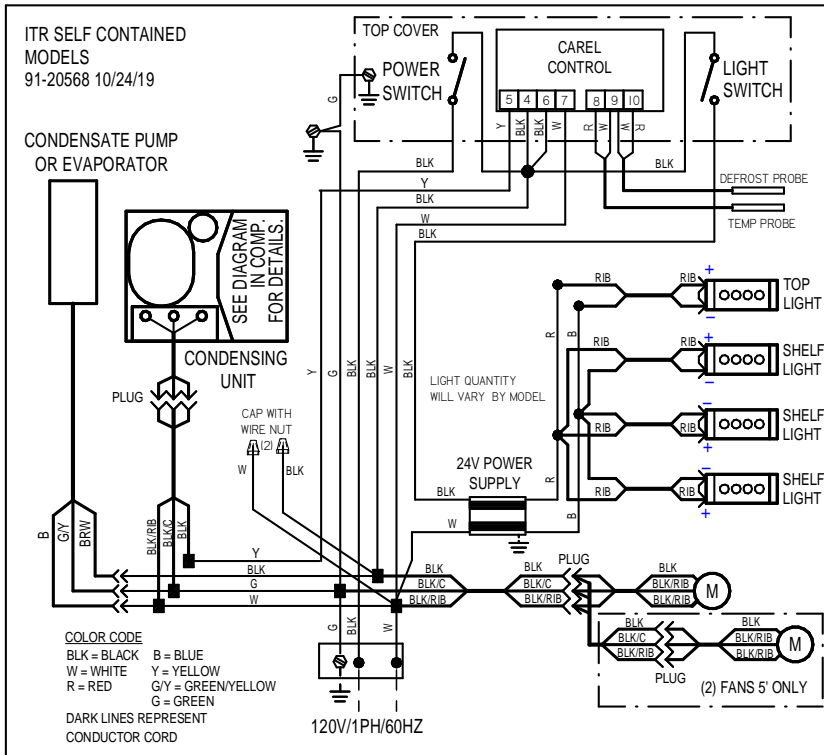

ITRSS6026, ITRSS6034 Refrigerated Self Contained (Before 12/1/19)

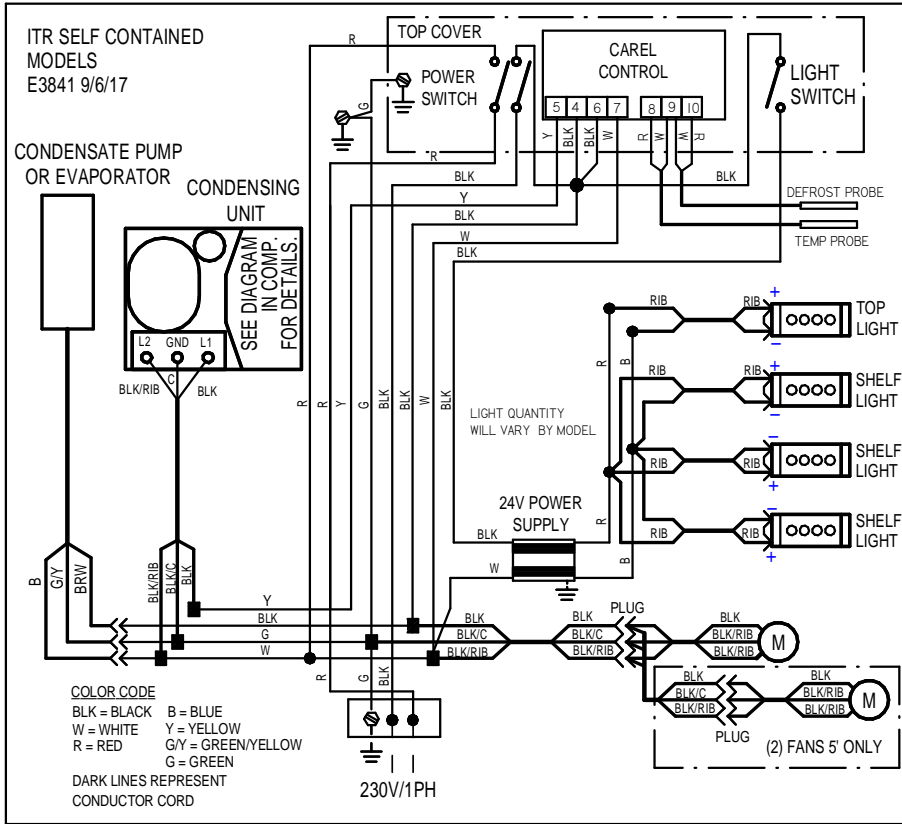

ITRSS6026, ITRSS6034 Refrigerated Self Contained (After 12/1/19)

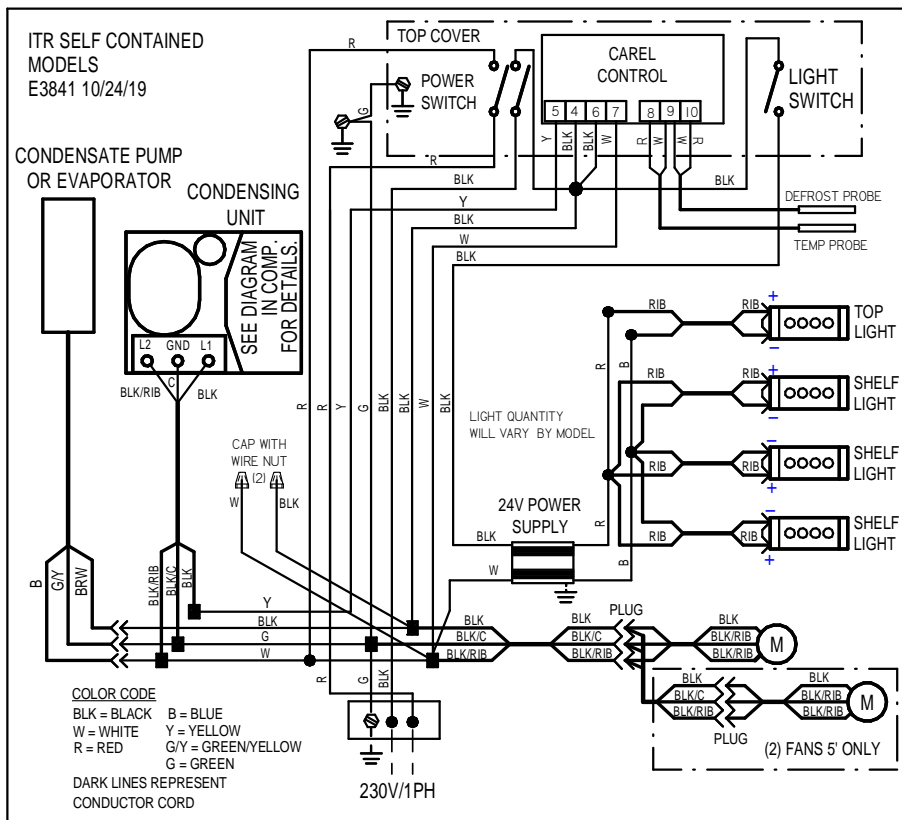

All Refrigerated Remote (Before 12/1/19)

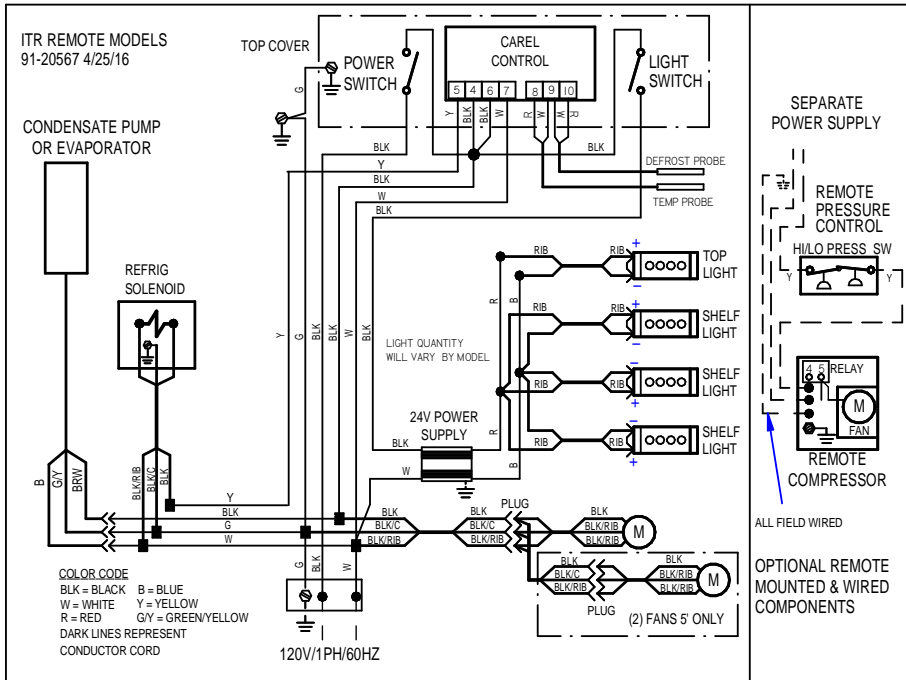

All Refrigerated Remote (After 12/1/19)

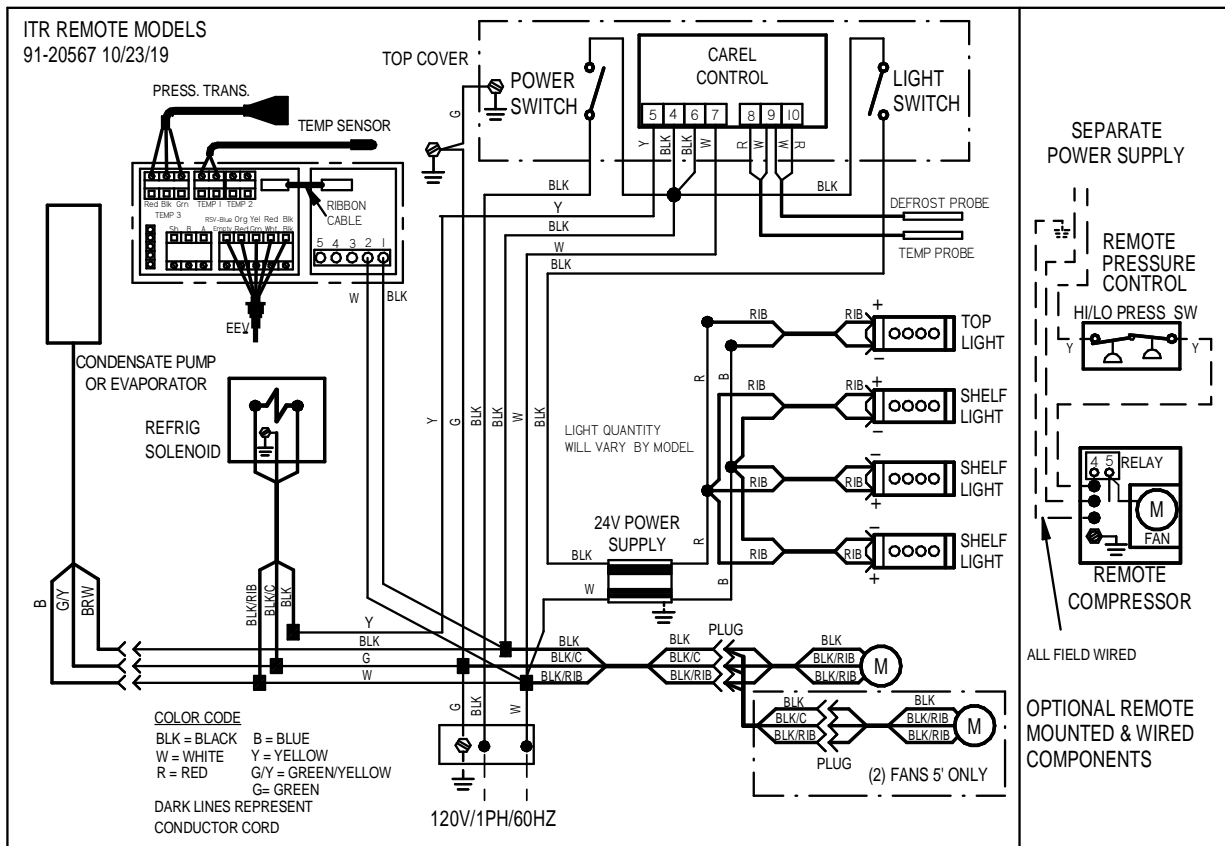

All Refrigerated Remote (After 7/1/24)

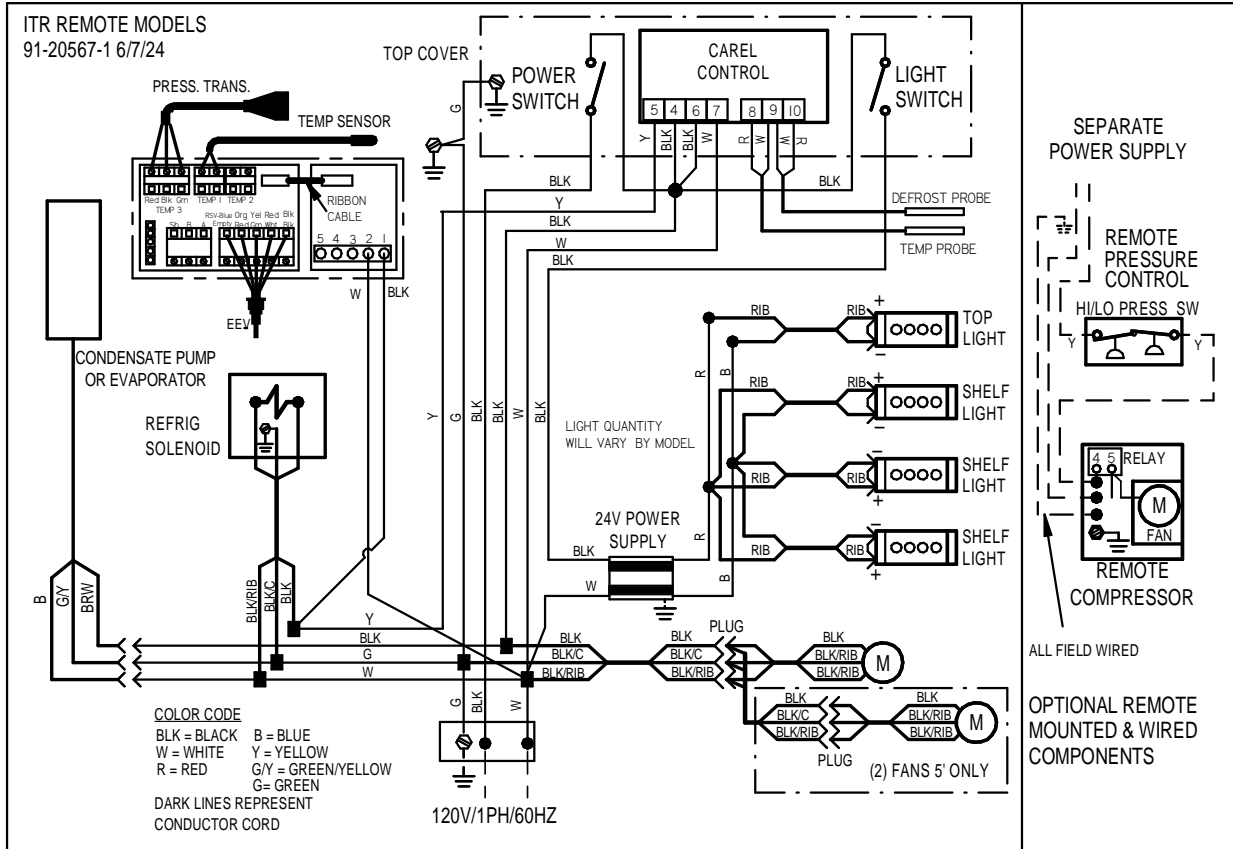

REPLACEMENT PARTS

(E3788 EXCEL)

ELECTICAL COMPONENTS

MODELS	LIGHT SWITCH	POWER SWITCH	LIGHT POWER SUPPLY	LIGHT 24V LED STRIP	SHELF LIGHT CORD	SC MAIN WIRING DIAGRAM	REMOTE MAIN WIRING DIAGRAM	DRY MAIN WIRING DIAGRAM	EEV CONTROL (SS ONLY)	EEV TEMP CONTROL (SS ONLY)	EEV PRESSURE (SS ONLY)
ITD36	4I-11066	4I-11066	39-20555	42-20870-29C35	43-20475			9I-20579			
ITD48	4I-11066	4I-11066	39-20555	42-20870-40C35	43-20475			9I-20579			
ITD60	4I-11066	4I-11066	39-20555	42-20870-51C35	43-20475			9I-20579			
ITDSS36	4I-11066	4I-11066	39-20555	42-20870-29C35	43-20475			9I-20579			
ITDSS48	4I-11066	4I-11066	39-20555	42-20870-40C35	43-20475			9I-20579			
ITDSS60	4I-11066	4I-11066	39-20555	42-20870-51C35	43-20475			9I-20579			
ITDSS36F	4I-11066	4I-11066	39-20555	42-20870-29C35	43-20475						
ITDSS48F	4I-11066	4I-11066	39-20555	42-20870-40C35	43-20475						
ITDSS60F	4I-11066	4I-11066	39-20555	42-20870-51C35	43-20475						
ITR36 & ITRSS36	4I-11066	4I-11066	39-20555	42-20870-29C35	43-20475	9I-20568	9I-20567		32-21223	32-21224	32-21225
ITR48 & ITR48	4I-11066	4I-11066	39-20555	42-20870-40C35	43-20475	9I-20568	9I-20567		32-21223	32-21224	32-21225
ITR60	4I-11066	4I-11066	39-20555	42-20870-51C35	43-20475	9I-20568	9I-20567		32-21223	32-21224	32-21225
ITRSS60	4I-11066	4I-18186	39-20555	42-20870-51C35	43-20475	E3841	9I-20567		32-21223	32-21224	32-21225

REFRIGERATION COMPONENTS

MODELS	CONDENSING UNIT (SCI) Before 1/22 = After 1/22	EVAPORATOR COIL	EXPANSION VALVE	EVAPORATOR FAN MOTOR	EVAPORATOR FAN BLADE	FILTER DRIER	ELECTRONIC CONTROL	TEMPERATURE PROBE	CONDENSATE PAN ASSY	ELECTRONIC EXPANSION VALVE	OPT. EVAP FAN ON/OFF	ELECTRONIC CONTROL
ITR36	30-20347	33-16019	32-20431	4I-11628	72-11450	32-12626	32-19864-14	32-19094	40-20420	32-21228		32-21382-14
ITR48	30-20513	33-16020	32-12625	4I-11628	72-11450	32-12626	32-19864-14	32-19094	40-20420	32-21228		32-21382-14
ITR60	30-20513	33-18283	32-12625	4I-11628	72-11450	32-12626	32-19864-14	32-19094	40-20420	32-21228		32-21382-14
ITRSS36	30-20347	33-17315-1	32-20431	4I-20864	72-32507	32-12626	32-19864-15	32-19094	SA5202-1	32-21228		-
ITRSS48	30-20513	33-17315-2	32-12625	4I-20864	72-32507	32-12626	32-19864-15	32-19094	SA5202-1	32-21228		-
ITRSS60	30-20934 = 30-21495	33-17315-3	32-12625	4I-20942	72-11450	32-12626	32-19865-15	32-19094	SA5202-2	32-21228		-

MODELS	CONDO PUMP 120V	REMOTE REFRIG SOLENOID
ALL	47-15686	32-30141

GLASS COMPONENTS

MODELS	FRONT	TOP GLASS	END GLASS	END GLASS	END GLASS	END GLASS	FRONT	FRONT
ITD3626	5I-20598-4	5I-20599-4	SA5830-IL	SA5830-IR	SA5830-3L	SA5830-3R	64-20476-1	64-20476-5
ITD4826	5I-20598-5	5I-20599-4	SA5830-IL	SA5830-IR	SA5830-3L	SA5830-3R	64-20476-2	64-20476-5
ITD6026	5I-20598-6	5I-20599-4	SA5830-IL	SA5830-IR	SA5830-3L	SA5830-3R	64-20476-3	64-20476-5
ITD3634	5I-20598-1	5I-20599-1	SA5830-L	SA5830-R	SA5830-2L	SA5830-2R	64-20476-1	64-20476-4
ITD4834	5I-20598-2	5I-20599-2	SA5830-L	SA5830-R	SA5830-2L	SA5830-2R	64-20476-2	64-20476-4
ITD6034	5I-20598-3	5I-20599-3	SA5830-L	SA5830-R	SA5830-2L	SA5830-2R	64-20476-3	64-20476-4
ITDSS3626		5I-20599-1	SA5830-IL	SA5830-IR	SA5830-3L	SA5830-3R		
ITDSS4826		5I-20599-2	SA5830-IL	SA5830-IR	SA5830-3L	SA5830-3R		
ITDSS6026		5I-20599-3	SA5830-IL	SA5830-IR	SA5830-3L	SA5830-3R		
ITDSS3634		5I-20599-1	SA5830-L	SA5830-R	SA5830-2L	SA5830-2R		
ITDSS4834		5I-20599-2	SA5830-L	SA5830-R	SA5830-2L	SA5830-2R		
ITDSS6034		5I-20599-3	SA5830-L	SA5830-R	SA5830-2L	SA5830-2R		
ITDSS3626	15-20635-1		SA583I-IL	SA583I-IR	SA583I-3L	SA583I-3R		
ITDSS4826	15-20635-2		SA583I-IL	SA583I-IR	SA583I-3L	SA583I-3R		
ITDSS6026	15-20635-3		SA583I-IL	SA583I-IR	SA583I-3L	SA583I-3R		
ITDSS3634	15-20635-1		SA583I-L	SA583I-R	SA583I-2L	SA583I-2R		
ITDSS4834	15-20635-2		SA583I-L	SA583I-R	SA583I-2L	SA583I-2R		
ITDSS6034	15-20635-3		SA583I-L	SA583I-R	SA583I-2L	SA583I-2R		
ITR3626	50-20471-4	50-20472-1	SA5830-IL	SA5830-IR	SA5830-3L	SA5830-3R	64-20476-1	64-20476-5
ITR4826	50-20471-5	50-20472-2	SA5830-IL	SA5830-IR	SA5830-3L	SA5830-3R	64-20476-2	64-20476-5
ITR6026	50-20471-6	50-20472-3	SA5830-IL	SA5830-IR	SA5830-3L	SA5830-3R	64-20476-3	64-20476-5
ITR3634	50-20471-1	50-20472-1	SA5830-L	SA5830-R	SA5830-2L	SA5830-2R	64-20476-1	64-20476-4
ITR4834	50-20471-2	50-20472-2	SA5830-L	SA5830-R	SA5830-2L	SA5830-2R	64-20476-2	64-20476-4
ITR6034	50-20471-3	50-20472-3	SA5830-L	SA5830-R	SA5830-2L	SA5830-2R	64-20476-3	64-20476-4
ITRSS3626	15-20635-1		SA583I-IL	SA583I-IR	SA583I-3L	SA583I-3R		
ITRSS4826	15-20635-2		SA583I-IL	SA583I-IR	SA583I-3L	SA583I-3R		
ITRSS6026	15-20635-3		SA583I-IL	SA583I-IR	SA583I-3L	SA583I-3R		
ITRSS3634	15-20635-1		SA583I-L	SA583I-R	SA583I-2L	SA583I-2R		
ITRSS4834	15-20635-2		SA583I-L	SA583I-R	SA583I-2L	SA583I-2R		
ITRSS6034	15-20635-3		SA583I-L	SA583I-R	SA583I-2L	SA583I-2R		

DOOR COMPONENTS - BEFORE 3/1/21

MODELS	DOOR LEFT CLEAR	DOOR RIGHT CLEAR	DOOR LEFT REFLECTIVE	DOOR RIGHT REFLECTIVE	MODELS	DOOR OUTER CLEAR	DOOR INNER CLEAR	DOOR OUTER REFLECTIVE	DOOR INNER REFLECTIVE
IT 3626	53-20467-4	53-20468-4	53-20467-4A	53-20468-4A	ITRSS 3626	53-20698-4	53-20699-4	53-20698-4A	53-20699-4A
IT 4826	53-20467-5	53-20468-5	53-20467-5A	53-20468-5A	ITRSS 4826	53-20698-5	53-20699-5	53-20698-5A	53-20699-5A
IT 6026	53-20467-6	53-20468-6	53-20467-6A	53-20468-6A	ITRSS 6026	53-20698-6	53-20699-6	53-20698-6A	53-20699-6A
IT 3634	53-20467-1	53-20468-1	53-20467-1A	53-20468-1A	ITRSS 3634	53-20698-1	53-20699-1	53-20698-1A	53-20699-1A
IT 4834	53-20467-2	53-20468-2	53-20467-2A	53-20468-2A	ITRSS 4834	53-20698-2	53-20699-2	53-20698-2A	53-20699-2A
IT 6034	53-20467-3	53-20468-3	53-20467-3A	53-20468-3A	ITRSS 6034	53-20698-3	53-20699-3	53-20698-3A	53-20699-3A

DOOR COMPONENTS - AFTER 3/1/21

MODELS	DOOR LEFT	DOOR	DOOR LEFT	DOOR RIGHT	MODELS	DOOR OUTER	DOOR INNER	DOOR	DOOR INNER
IT 3626	53-21400-4	53-21399-4	53-21400-4A	53-21399-4A	ITRSS 3626	53-20698-4	53-20699-4	53-20698-4A	53-20699-4A
IT 4826	53-21400-5	53-21399-5	53-21400-5A	53-21399-5A	ITRSS 4826	53-20698-5	53-20699-5	53-20698-5A	53-20699-5A
IT 6026	53-21400-6	53-21399-6	53-21400-6A	53-21399-6A	ITRSS 6026	53-20698-6	53-20699-6	53-20698-6A	53-20699-6A
IT 3634	53-21400-1	53-21399-1	53-21400-1A	53-21399-1A	ITRSS 3634	53-20698-1	53-20699-1	53-20698-1A	53-20699-1A
IT 4834	53-21400-2	53-21399-2	53-21400-2A	53-21399-2A	ITRSS 4834	53-20698-2	53-20699-2	53-20698-2A	53-20699-2A
IT 6034	53-21400-3	53-21399-3	53-21400-3A	53-21399-3A	ITRSS 6034	53-20698-3	53-20699-3	53-20698-3A	53-20699-3A

SHELF COMPONENTS

MODELS	GLASS SHELF 11"	GLASS SHELF 14"	GLASS SHELF 17"	SHELF BRACKET 9"	SHELF BRACKET 12"	SHELF BRACKET 15"	SHELF SUPORT (NO LIGHT)
IT 3626	-	52-20473-2	52-20473-3	-	M20441-2L/IR	M20441-3L/IR	M20379-1
IT 4826	-	52-20473-5	52-20473-6	-	M20441-2L/IR	M20441-3L/IR	M20379-2
IT 6026	-	52-20473-8	52-20473-9	-	M20441-2L/IR	M20441-3L/IR	M20379-3
IT 3634	52-20473-1	52-20473-2	52-20473-3	M20441-1L/IR	M20441-2L/IR	M20441-3L/IR	M20379-1
IT 4834	52-20473-4	52-20473-5	52-20473-6	M20441-1L/IR	M20441-2L/IR	M20441-3L/IR	M20379-2
IT 6034	52-20473-7	52-20473-8	52-20473-9	M20441-1L/IR	M20441-2L/IR	M20441-3L/IR	M20379-3

California Residents Only.

⚠ WARNING

This product can expose you to chemicals including chromium which is known to the State of California to cause cancer and birth defects or other reproductive harm. For more information go to www.P65Warnings.ca.gov

