



*The Signature of Quality®*

INSTALLATION & OPERATIONS INSTRUCTIONS  
*VRSS, VRSL, & VRSSL-MLK: Self-Contained & Remote Refrigerated*  
*VNSS: Non-Refrigerated Displays*



---

---

# TABLE OF CONTENTS

---

---

(1)	Introduction .....	3
1.1	Serial Number .....	3
(2)	Warning Labels & Safety Instructions .....	4
(3)	REFRIGERATION WARNING INSTALLATION-REPAIR-DECOMMISSIONING .....	5
(4)	Base Component LayoutS .....	12
(5)	Panel Removal.....	18
5.1	VRSS & VRSL MODELS .....	18
5.2	VRSL-MLK MODEL .....	19
(6)	PRIOR TO UNPACKING EQUIPMENT!.....	20
6.1	Locating The Display Case .....	20
6.2	Removing Case From Shipping Skid .....	22
6.3	Single Case Installation (Stand alone units) .....	24
6.4	Installation for joined cases (Lineups).....	24
6.5	installation in an alcove.....	27
(7)	Shelf installation and removal .....	28
(8)	Security Night Cover (Optional).....	31
(9)	Slide-In Models -Leg & Caster Adjustments .....	32
(10)	Electronic Temperature Control (Refrigerated units only).....	34
(11)	Refrigeration Operation.....	37
11.2	Remote Units There are special requirements for A2L refrigerants such as R454C .....	39
(12)	Refrigerant detection and mitigation system.....	43
(13)	Initial Startup (Refrigerated units only) .....	45
(14)	Cleaning Instructions.....	47
14.1	Daily Cleaning .....	47
14.2	Weekly Cleaning.....	47
14.3	Cleaning Condenser Coil .....	49
(15)	Service.....	50
(16)	SALE & Decommissioning .....	51
(17)	Electrical and refrigeration specs .....	52
(18)	Wiring Diagram .....	54
18.1	VRSS Self Contained R290 .....	54
18.2	VRSS Remote .....	54
18.3	VNSS.....	55
18.4	VRSL-MLK.....	56
(19)	Service Parts .....	57

---



---

# (1) INTRODUCTION

---

---

Thank you for purchasing a Federal Industries display case. This manual contains important instructions for installing and servicing your new display case. A repair parts list and wiring diagram are also included in the manual. Read all these documents carefully before installing or servicing your case.

	<p><b>NOTICE</b></p> <p>Read this manual before installing your case. Keep this manual and refer to it before doing any service on the equipment. Failure to do so could result in personal injury or damage to the case.</p>
	<p><b>NOTICE</b></p> <p>Installation and service of the electrical components in the case must be performed by a licensed electrician.</p> <p>The portions of this manual covering components contain technical instructions intended only for persons qualified to perform electrical work.</p>
	<p><b>DANGER</b></p> <p>Improper or faulty hookup of electrical components in the case can result in severe injury or death.</p> <p>All electrical wiring hookups must be done in accordance with all applicable local, regional, or national standards.</p>

## 1.1 SERIAL NUMBER

Record the model and serial numbers of the case for easy reference. Always refer to both model and serial numbers in your correspondence with Federal regarding the case.

Case Model \_\_\_\_\_ Serial Number \_\_\_\_\_

This manual cannot cover every installation, use, or service situation. If you need additional information, call or write us:

### WARRANTY/TECHNICAL SERVICE DEPARTMENT

Parts Town  
1200 Greenbriar Dr.  
Addison, IL 60101  
Toll Free: (833) 238-8168

Email: [techservice@partstown.com](mailto:techservice@partstown.com)



## (2) WARNING LABELS & SAFETY INSTRUCTIONS

	<p><b>This is the safety-alert symbol. When you see this symbol on your case or in the manual, be alert to the potential for personal injury or damage to your equipment.</b></p>
---	---

Be sure you understand all the safety messages and always follow recommended precautions and safe operating procedures.

	<p><b>NOTICE TO EMPLOYERS:</b></p> <p><b>You must make sure that everyone who installs, uses, or services your case is thoroughly familiar with all safety information and procedures.</b></p>
---	--

Important safety information is presented in this section and throughout the manual. The following signal words are used in the warning and safety messages:

DANGER:	Severe injury or death <b>will</b> occur if you ignore the message.
WARNING:	Severe injury or death <b>can</b> occur if you ignore the message.
CAUTION:	Minor injury or damage to your case <b>can</b> occur if you ignore the message.
NOTICE:	This is important installation, operation, or service information. If you ignore the message, you may damage your case.

The warning and safety labels shown throughout this manual are placed on your Federal Industries case at the factory. Follow all warning label instructions. If any warning or safety labels become lost or damaged, call our customer service department at (800) 356-4206 for replacements.

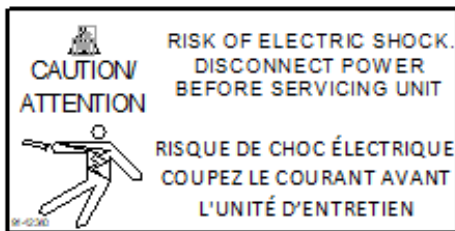

*This label is located behind the removable base deck panels display and under deck pans.*



*This label is located under display*

<p>DANGER – Risk of fire or explosion. Flammable refrigerant used. Consult repair manual/owner's guide before attempting to service this product. all safety precautions must be followed</p> <p style="text-align: right;">91-2181-4</p>	<p>DANGER — Risque d'incendie ou d'explosion. Fluide frigorigène utilisé. Consulter le guide propriétaire ou le manuel de réparations avant du d'essayer d'installer ou de réparer ce produit. Toutes les précautions de sécurité doivent être suivies.</p> <p style="text-align: right;">91-2181-4</p>
---	---

*This label is located by condensing unit*

---

## (3) REFRIGERATION WARNING INSTALLATION-REPAIR- DECOMMISSIONING

---



*This is the Danger-Flammable symbol. When you see this symbol on your case or in the manual, be alert to the potential for risk of fire or explosion.*

Be sure you understand all the safety messages and always follow recommended precautions and safe operating procedures.

### **DANGER**



**Risk of fire or explosion. Flammable refrigerant used. To be repaired only by trained service personnel. Do not puncture refrigerant tubing. Dispose of properly in accordance with federal or local regulations**

**Consult repair manual/owner's guide before attempting to service this product. All safety precautions must be followed.**

**Follow handling instructions carefully in compliance with national regulations.**

**Auxiliary devices which may be ignition sources shall not be installed in the ductwork, other than auxiliary devices listed for use with the specific appliance.**

**Do not store explosive substances (such as aerosol cans with a flammable propellant) in this case.**

**Do not use an electrical appliance INSIDE the food storage compartments unless its type is recommended by manufacturer.**

**Flammable refrigerant type specified on case nameplate is on the serial label.**

**APPLIES TO R290 REFRIGERANT MODELS ONLY! Contains a charge of R290 refrigerant with a lower flammability limit (LFL) of .038kg/m<sup>3</sup>. See table for amount of charge.**

## WARNING

- Do not use means to accelerate the defrosting process or to clean, other than those recommended by the manufacturer.
- The appliance shall be stored in a room without continuously operating ignition sources  
For example: open flames, an operating gas appliance or an operating electric heater.
- Do not pierce or burn.
- Be aware that refrigerants may not contain an odor.

## MISE EN GARDE

- Ne pas utiliser de moyens autres que ceux recommandés par le fabricant pour accélérer le processus de dégivrage ou pour nettoyer l'appareil.
- L'appareil doit être entreposé dans un local ne contenant pas de sources d'inflammation permanentes (flammes nues, appareil à gaz ou dispositif de chauffage électrique en fonctionnement, par exemple).
- Ne pas percer ou brûler.
- Attention, les fluides frigorigènes peuvent ne pas dégager d'odeur.

**3. Qualification:** All refrigeration and electrical maintenance, service, and repair must be performed by a Certified Technician that is trained in the required flammable refrigerants safety procedures. Technicians must read the entire section "REFRIGERATION WARNINGS SECTION" of this manual.

Including but not limited to the following:

- a) breaking into the refrigerating circuit.
- b) opening of sealed components.
- c) opening of ventilated enclosures.

**4. Checks to Area:** Prior to beginning work on systems containing FLAMMABLE REFRIGERANTS, safety checks are necessary to ensure that the risk of ignition is minimized prior to conducting work on the system.

- Capacitors are discharged: this shall be done in a safe manner to avoid the possibility of sparking.
- No live electrical components and wiring are exposed while charging, recovering or purging the system.
- Continuity of earth bonding.
- Work shall be undertaken under a controlled procedure to minimize the risk of a flammable gas or vapor being present while the work is being performed.

-All maintenance staff and others working in the local area should be instructed on the nature of the work being carried out. Work in confined spaces shall be avoided.

-The area shall be checked with an appropriate refrigerant detector prior to and during work, to ensure the technician is aware of potentially toxic or flammable atmospheres.

Ensure that the leak detection equipment being used is suitable for use with all applicable refrigerants, i.e., non-sparking, adequately sealed, or intrinsically safe.

-If any hot work is to be conducted on the refrigerating equipment or any associated parts, appropriate fire extinguishing equipment shall be available on hand. A dry chemical or CO2 fire extinguisher should be adjacent to the charging area.

-No person carrying out work in relation to a REFRIGERATING SYSTEM which involves exposing any pipe work shall use any sources of ignition in such a manner that it may lead to the risk of fire or explosion. All possible ignition sources, including cigarette smoking, should be kept sufficiently far away from the site of installation, repairing, removing and disposal, during which refrigerant can possibly be released to the surrounding space. Prior to work taking place, the area around the equipment shall be surveyed to make sure that there are no flammable hazards or ignition risks. "No Smoking" signs shall be displayed.

-Ensure that the area is in the open or that it is adequately ventilated before breaking into the system or conducting any hot work. A degree of ventilation shall continue during the period that the work is carried out. The ventilation should safely disperse any released refrigerant and preferably expel it externally into the atmosphere.

-Where electrical components are being changed, they shall be fit for the purpose and to the correct specification so as to minimize the risk of possible ignition due to incorrect parts. At all times, the manufacturer's maintenance and service guidelines shall be followed. If in doubt, consult the manufacturer's technical department for assistance. The following checks shall be applied to installations using flammable refrigerants:

a) the actual REFRIGERANT CHARGE is in accordance with the room size within which the refrigerant containing parts are installed.

b) The ventilation machinery and outlets are operating adequately and are not obstructed.

c) Markings of the equipment continue to be visible and legible. Markings and signs that are illegible shall be corrected.

d) Refrigerating pipes or components are installed in a position where they are unlikely to be exposed to any substance which may corrode refrigerant containing

-Repair and maintenance to electrical components shall include initial safety checks and component inspection procedures. If a fault exists that could compromise safety, then no electrical supply shall be connected to the circuit until it is satisfactorily dealt with. If the fault cannot be corrected immediately but it is necessary to continue operation, an

An adequate temporary solution should be used. This shall be reported to the owner of the Initial safety checks shall include:

## **5. Repairs to sealed components**

-During repairs to sealed components, all electrical supplies shall be disconnected from the equipment being worked upon prior to any removal of sealed covers, etc. If it is necessary to have an electrical supply to equipment during servicing, then a permanently operating form of leak detection shall be located at the most critical point to warn of a potentially hazardous situation.

-Particular attention shall be paid to the following to ensure that by working on electrical components, the casing is not altered in such a way that the level of protection is affected. This shall include damage to cables, excessive number of connections, terminals not made to original specification, damage to seals, incorrect fitting of glands, etc. Ensure that the apparatus is mounted securely.

Ensure that seals or sealing materials have not degraded to the point that they no longer serve the purpose of preventing the egress of flammable atmospheres. Replacement parts shall be in accordance with the manufacturer's specifications.

-Do not apply any permanent inductive or capacitance loads to the circuit without ensuring that this will not exceed the permissible voltage and current permitted for the equipment in use.

NOTE The use of silicon sealants can inhibit the effectiveness of some types of leak detection equipment. Intrinsically safe components do not have to be isolated prior to working on them.

**8. Detection of flammable refrigerants:** Under no circumstances shall potential ignition sources be used in the searching for or detection of refrigerant leaks. A halide torch (or any other detector using a naked flame) shall not be used.

**The following leak detection methods are deemed acceptable for all refrigerant systems:**

-Electronic leak detectors may be used to detect refrigerant leaks but, in the case of FLAMMABLE REFRIGERANTS, the sensitivity might not be adequate or might need recalibration. (Detection equipment shall be calibrated in a refrigerant-free area.) Ensure that the detector is not a potential source of ignition and is suitable for the refrigerant used. Leak detection equipment shall be set at a percentage of the LFL of the refrigerant and shall be calibrated to the refrigerant employed, and the appropriate percentage of gas (25 % maximum) is confirmed.

-Leak detection fluids are also suitable for use with most refrigerants but the use of detergents containing chlorine shall be avoided as the chlorine can react with the refrigerant and corrode the copper pipework.

NOTE Examples of leak detection fluids are

- bubble method,
- fluorescent method agents.

If a leak is suspected, all naked flames shall be removed/extinguished.

If a leakage of refrigerant is found which requires brazing, all the refrigerants shall be recovered from the system, or isolated (by means of shut off valves) in a part of the system remote from the leak.

**9. Removal and Evacuation:** When breaking into the refrigerant circuit to make repairs-or for any other purpose-conventional procedures shall be used. However, for flammable refrigerants it is

important that the best practice be followed, since flammability is a consideration. The following procedure shall be adhered to:

- a. Safely remove refrigerant following local and national regulations.
- b. Purge the circuit with inert gas.
- c. Evacuate (optional for A2L).
- d. Purge with inert gas (optional for A2L).
- e. Open the circuit by cutting or brazing.

The refrigerant change shall be recovered into the correct recovery cylinders if venting is not allowed by local and national codes. For appliances containing flammable refrigerants, the system shall be purged with oxygen-free nitrogen to render the appliance safe for flammable refrigerants. This process might need to be repeated several times. Compressed air or oxygen shall not be used for purging refrigerant systems. For appliances containing flammable refrigerants, refrigerant purging shall be achieved by breaking the vacuum in the system with oxygen-free nitrogen and continuing to fill until the working pressure is achieved, then venting to atmosphere, and finally pulling down to a vacuum (optional for A2L). This process shall be repeated until no refrigerant is within the system (optional for A2L). When the final oxygen-free nitrogen change is used, the system shall be vented down to atmospheric pressure to enable work to take place. Ensure that the outlet for the vacuum pump is not close to any potential ignition sources and that ventilation is available.

**10. Charging procedures:** In addition to conventional charging procedures, the following requirements shall be followed.

- a. Ensure that contamination of different refrigerants does not occur when using charging equipment. Hoses or lines shall be as short as possible to minimize the amount of refrigerant contained in them.
- b. Cylinders should be kept in an appropriate position according to the instructions.
- c. Ensure that the REFRIGERATING SYSTEM is earthed prior to charging the system with refrigerant.
- d. Label the system when charging is complete (if not already).
- e. Extreme care shall be taken not to overfill the REFRIGERATING SYSTEM.

**11. Decommissioning:** Before carrying out this procedure, it is essential that the technician is completely familiar with the equipment and all its details. It is recommended good practice that all refrigerants are recovered safely. Prior to the task being carried out, an oil and refrigerant sample shall be taken in case analysis is required prior to re-use of recovered refrigerant. It is essential that electrical power is available before the task commences.

- a. Become familiar with the equipment and its operation.
- b. Isolate the system electrically.
- c. Before attempting the procedure, ensure that:
  - i. Mechanical handling equipment is available, if required, for handling refrigerant cylinders.
  - ii. All personal protective equipment is available and is being used correctly.
  - iii. The recovery process is always supervised by a competent person.
  - iv. Recovery equipment and cylinders conform to the appropriate standards.
- d. Pump down the refrigerant system, if possible.

- e. If a vacuum is not possible, make a manifold so that refrigerant can be removed from various parts of the system.
- f. Make sure that the cylinder is situated on the scales before recovery takes place.
- g. Start the recovery machine and operate in accordance with instructions.
- h. Do not overfill cylinders (no more than 80% volume liquid charge).
- i. Do not exceed the maximum working pressure of the cylinder, even temporarily.
- j. When the cylinders have been filled correctly and the process completed, make sure that the cylinders and the equipment are removed from the site properly and all isolation valves on the equipment are closed off.
- k. Recovered refrigerant shall not be charged into another refrigerating system unless it has been cleaned and checked.

**12. Labeling:** Equipment shall be labeled stating that it has been de-commissioned and emptied of refrigerant. The label shall be dated and signed. For appliances containing flammable refrigerants, ensure that there are labels on the equipment stating the equipment contains flammable refrigerant.

**13.Recovery:** When removing the refrigerant from a system, either for servicing or decommissioning, it is recommended good practice that all refrigerants are removed safely.

When transferring refrigerant into cylinders, ensure that only appropriate refrigerant recovery cylinders are employed. Ensure that the correct number of cylinders for holding the total system charge is available. All cylinders to be used are designated for the recovered refrigerant and labeled for that refrigerant (i.e., special cylinders for the recovery of refrigerant). Cylinders shall be complete with pressure-relief valve and associated shut-off valve in good working order. Empty recovery cylinders are evacuated and, if possible, cooled before recovery occurs.

The recovery equipment shall be in good working order with a set of instructions concerning the equipment that is at hand and shall be suitable for the recovery of all appropriate refrigerants including, when applicable, FLAMMABLE REFRIGERANTS. In addition, a set of calibrated weighing scales shall be available and in good working order. Hoses shall be complete with leak-free disconnect coupling and in good condition. Before using the recovery machine, check that it is in satisfactory working order, has been properly maintained and that any associated electrical components are sealed to prevent ignition in the event of refrigerant release. Consult manufacturer if in doubt.

The recovered refrigerant shall be returned to the refrigerant supplier in the correct recovery cylinder, and the relevant waste transfer note arranged. Do not mix refrigerants in recovery units and especially not in cylinders.

If compressors or compressor oils are to be removed, ensure that they have been evacuated to an acceptable level to make certain that FLAMMABLE REFRIGERANT does not remain within the lubricant. The evacuation process shall be carried out prior to returning the compressor to the suppliers. Only electric heating to the compressor body shall be employed to accelerate this process. When oil is drained from a system, it shall be carried out safely.

# Feature Identification

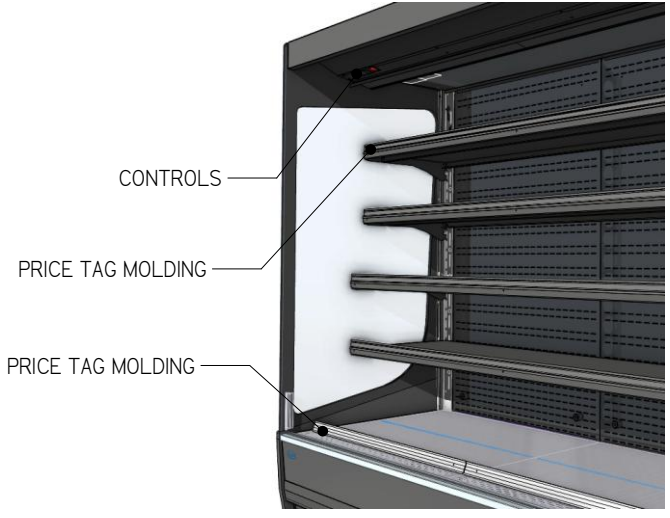
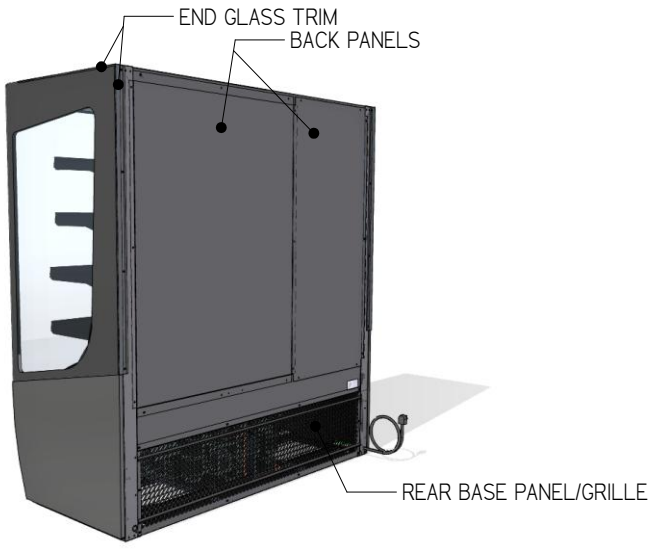
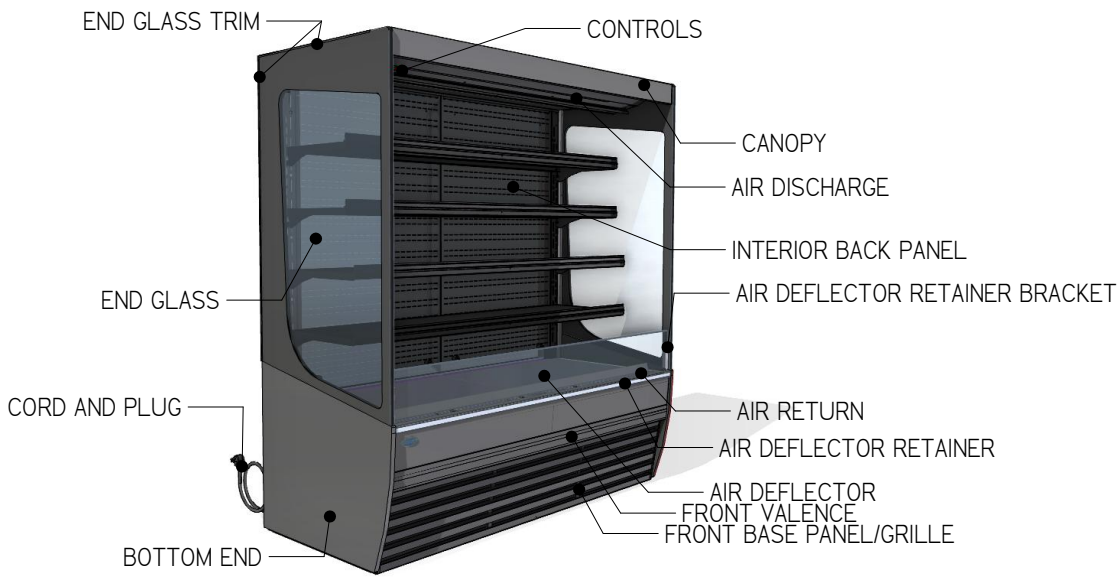

# (4) BASE COMPONENT LAYOUTS

## VRSL36 FIFO SELF CONTAINED

FRONT AIR IN AND OUT  
(SHOWN WITH NO END PANELS)

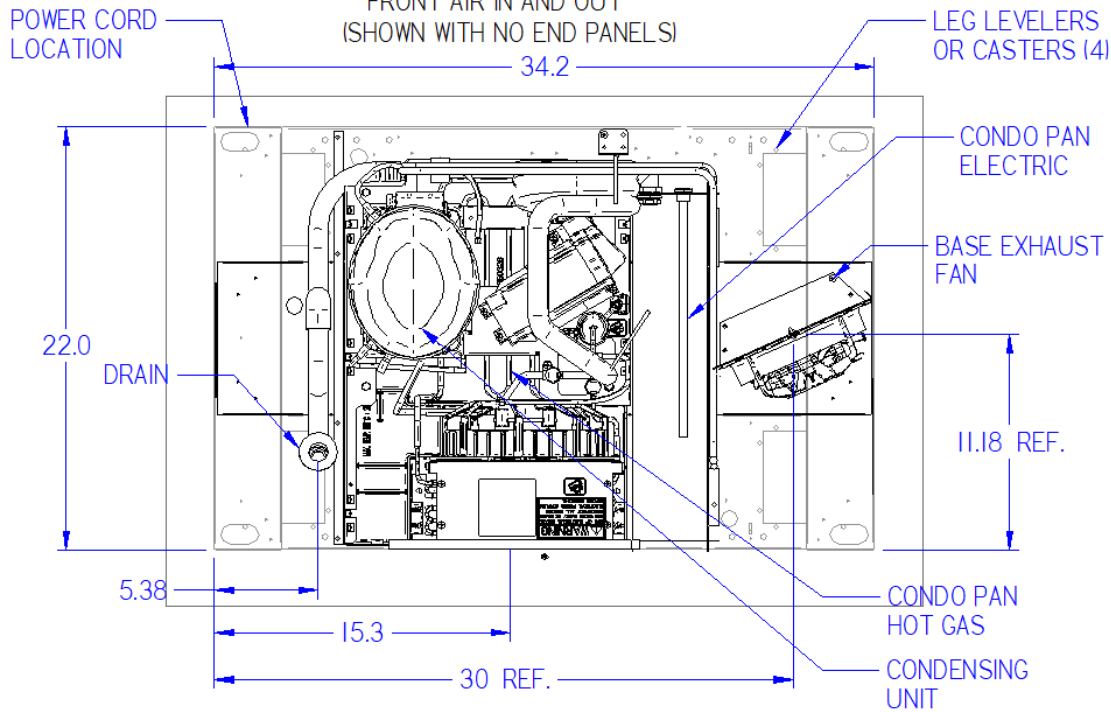

## VRSL48 SELF CONTAINED

FRONT AIR IN AND OUT  
(SHOWN WITH NO END PANELS)

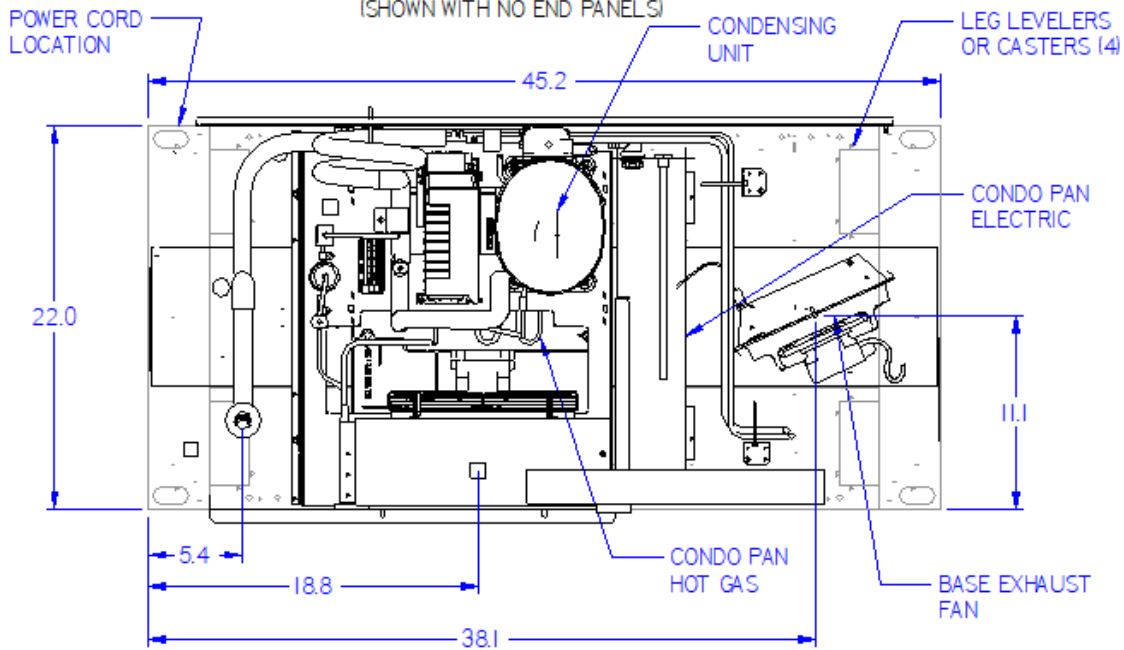

VRSL60 SELF CONTAINED

FRONT AIR IN AND OUT  
(SHOWN WITH NO END PANELS)

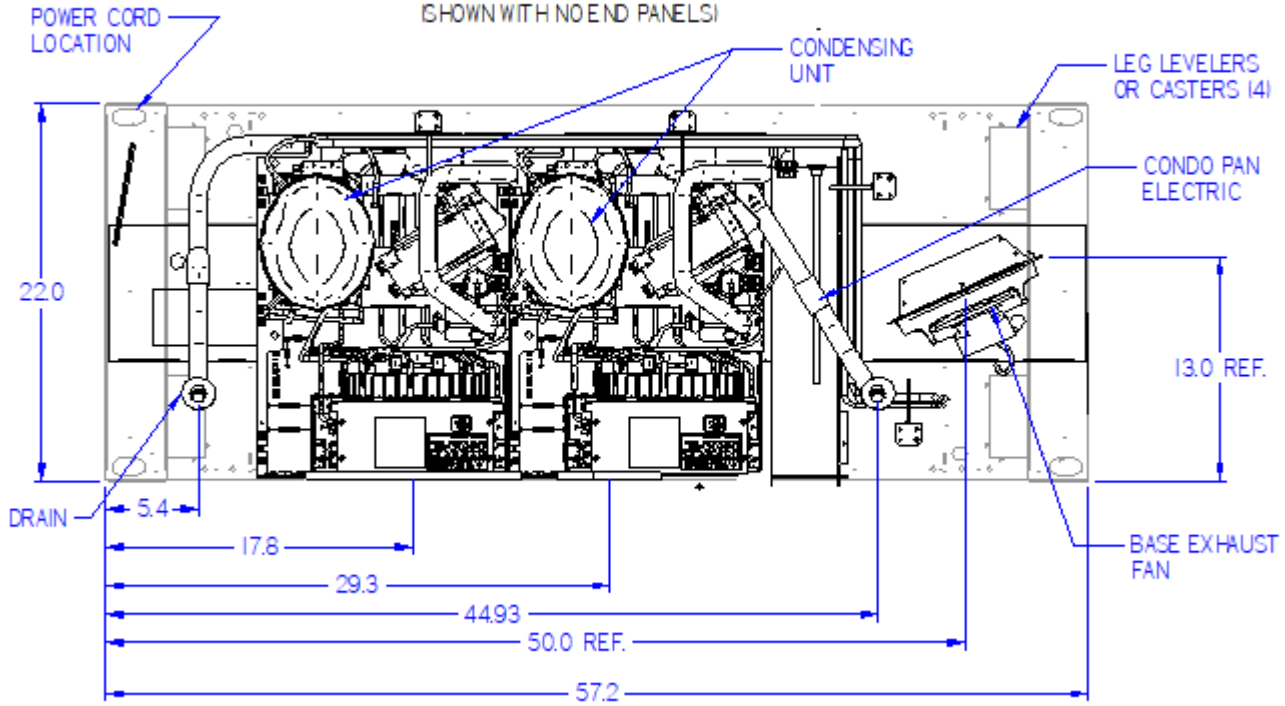

VRSL72 SELF CONTAINED

FRONT AIR IN AND OUT  
(SHOWN WITH NO END PANELS)

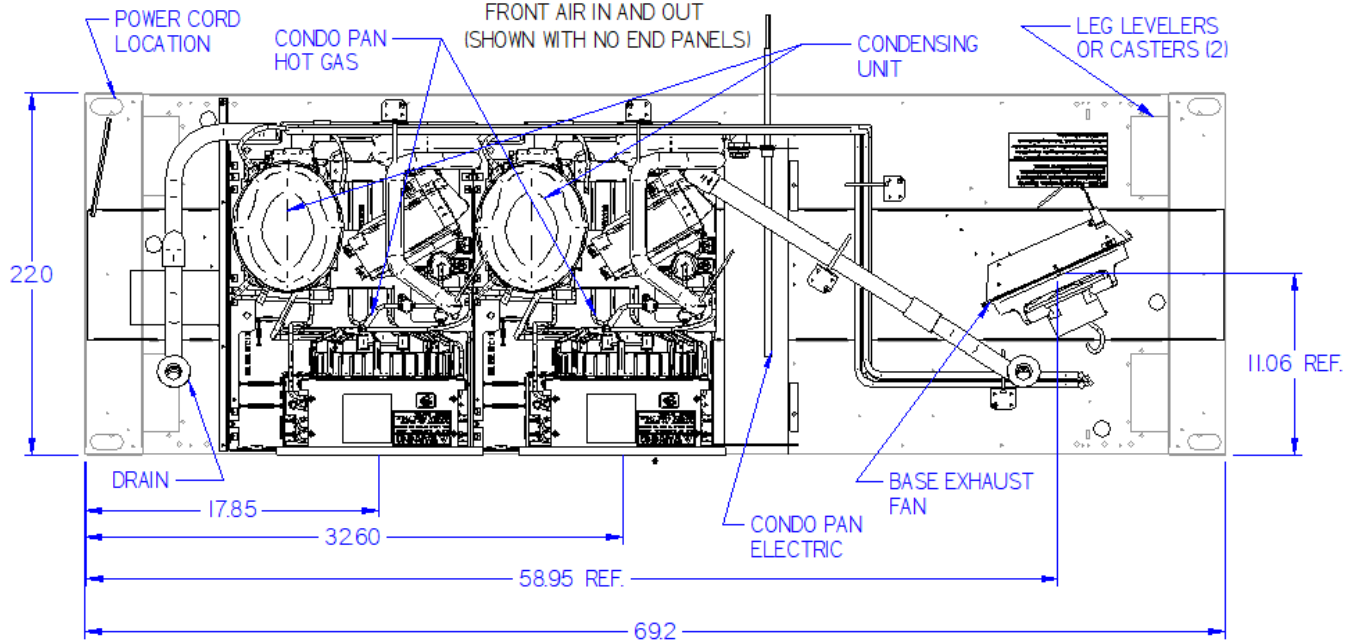

VRSS36 SELF CONTAINED  
FRONT AIR IN AND OUT  
(SHOWN WITH NO END PANELS)

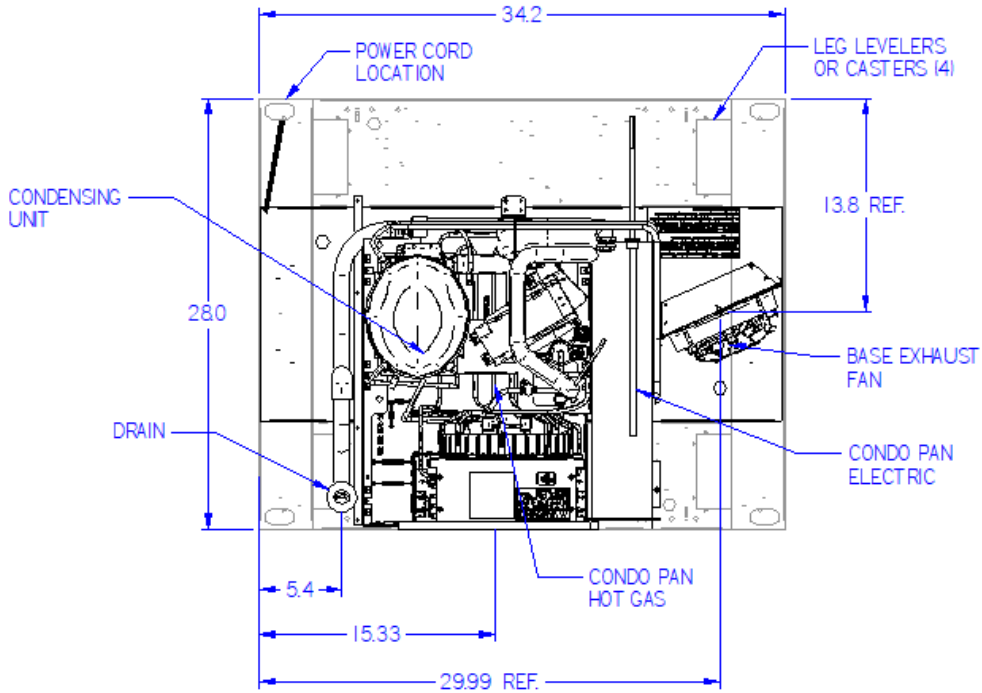

VRSS 48 SELF CONTAINED  
FRONT AIR IN AND OUT  
(SHOWN WITH NO END PANELS)

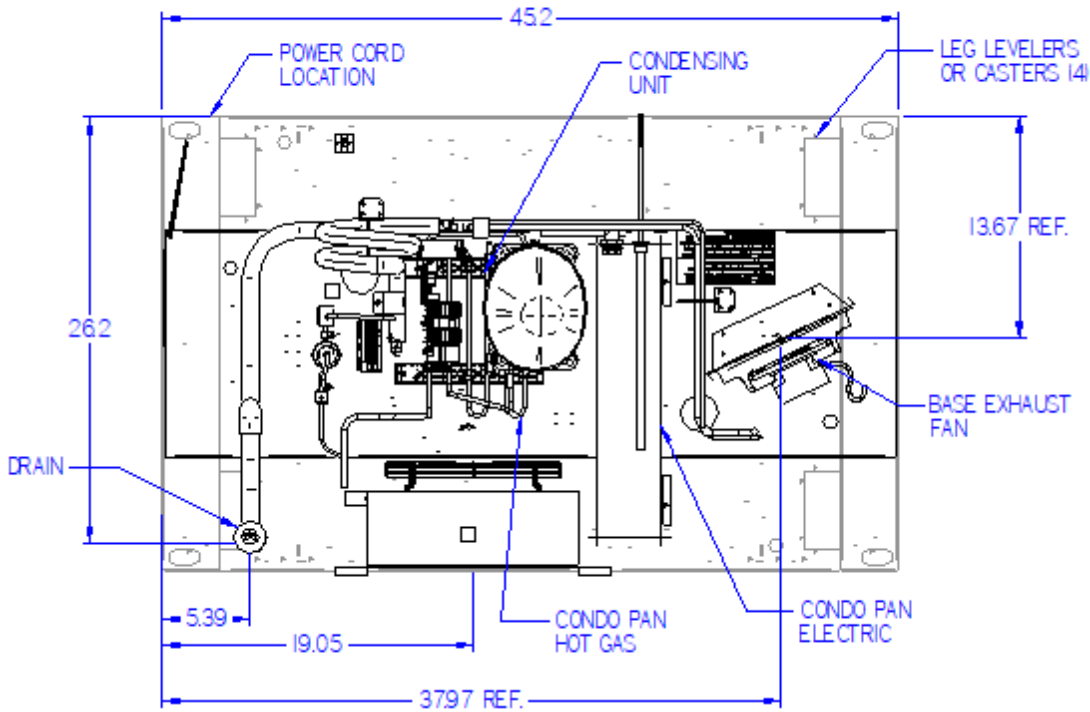

VRSS 60 SELF CONTAINED  
FRONT AIR IN AND OUT  
(SHOWN WITH NO END PANELS)

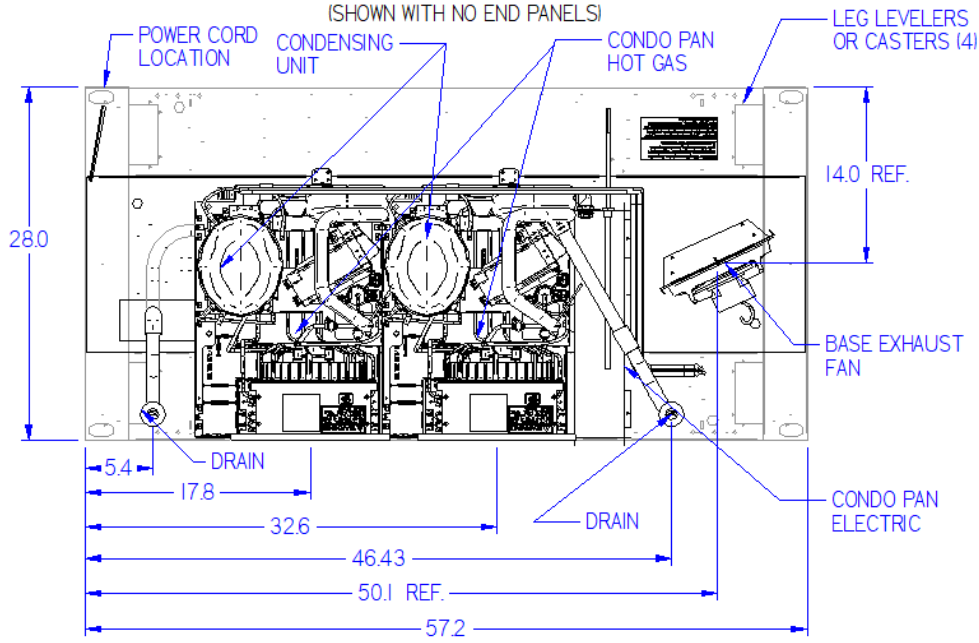

VRSS 72 SELF CONTAINED  
FRONT AIR IN AND OUT  
(SHOWN WITH NO END PANELS)

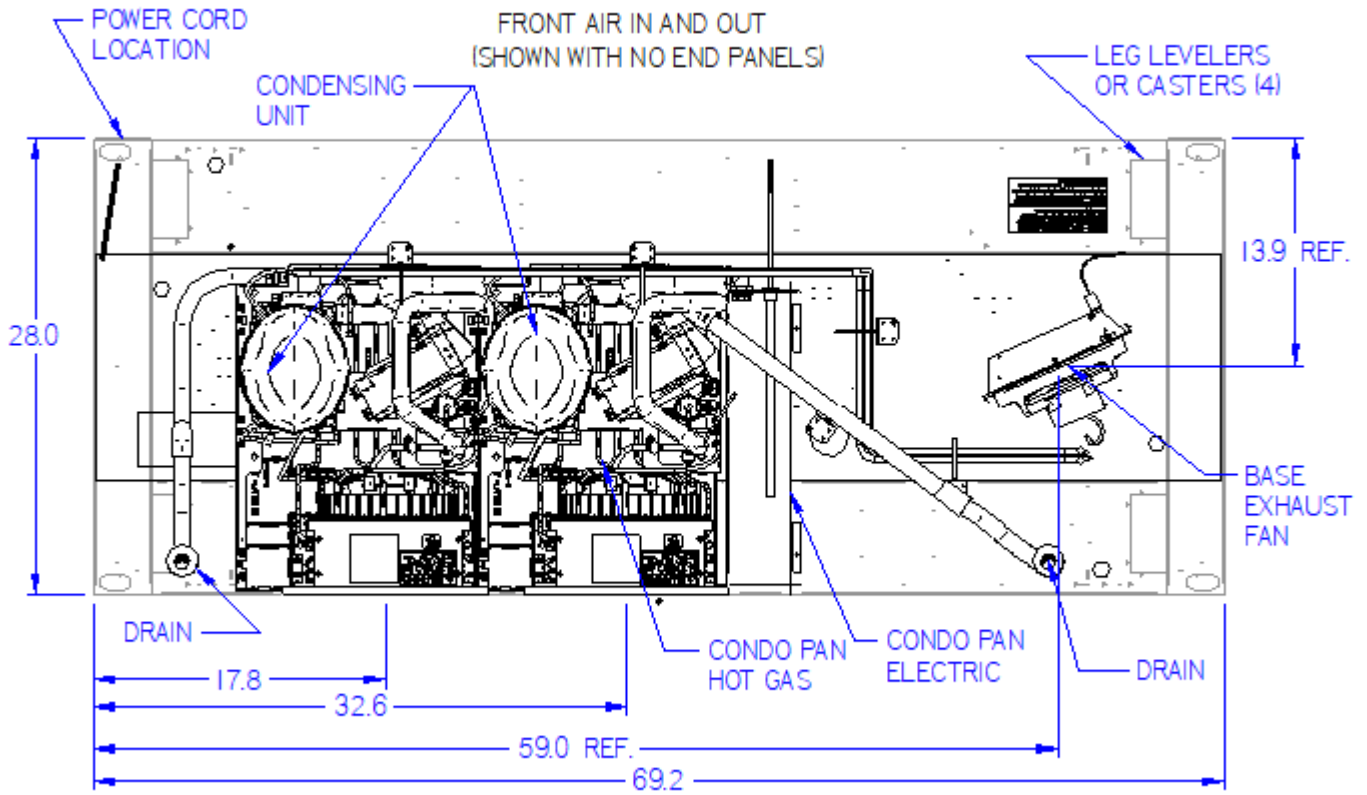

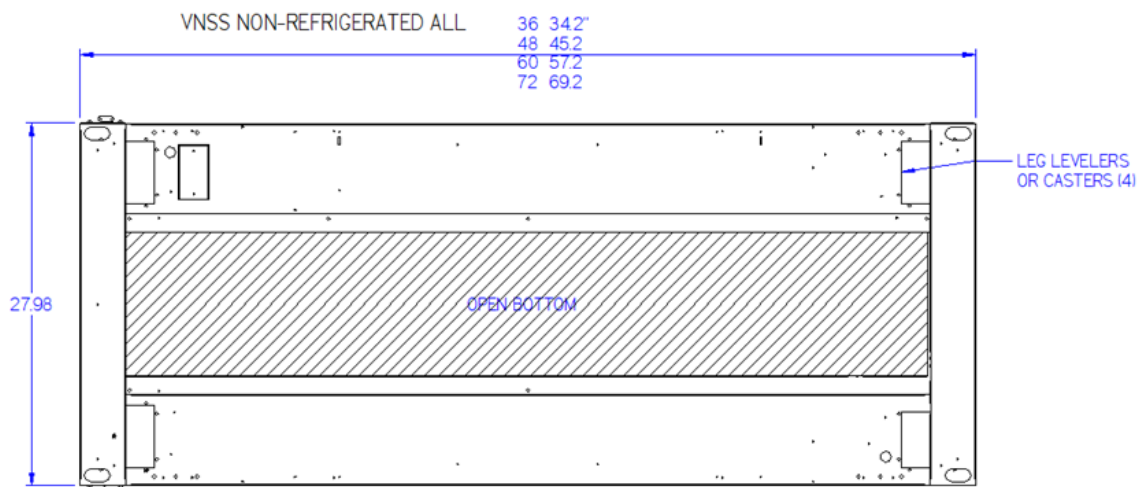
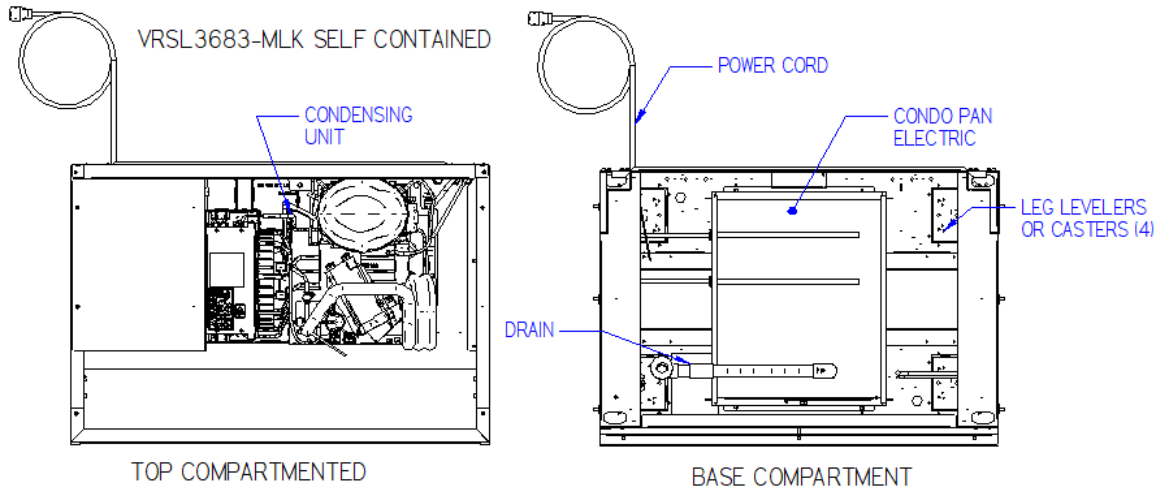

BEFORE 11/01/25

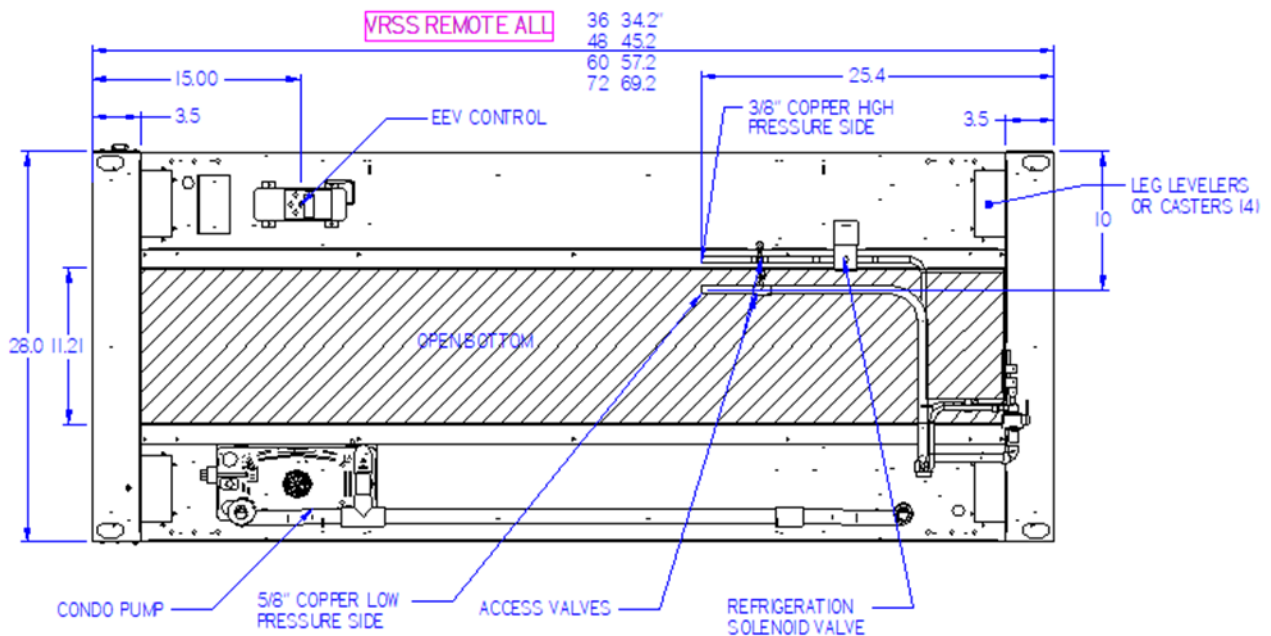

VRSS4860/4878 REMOTES R454c

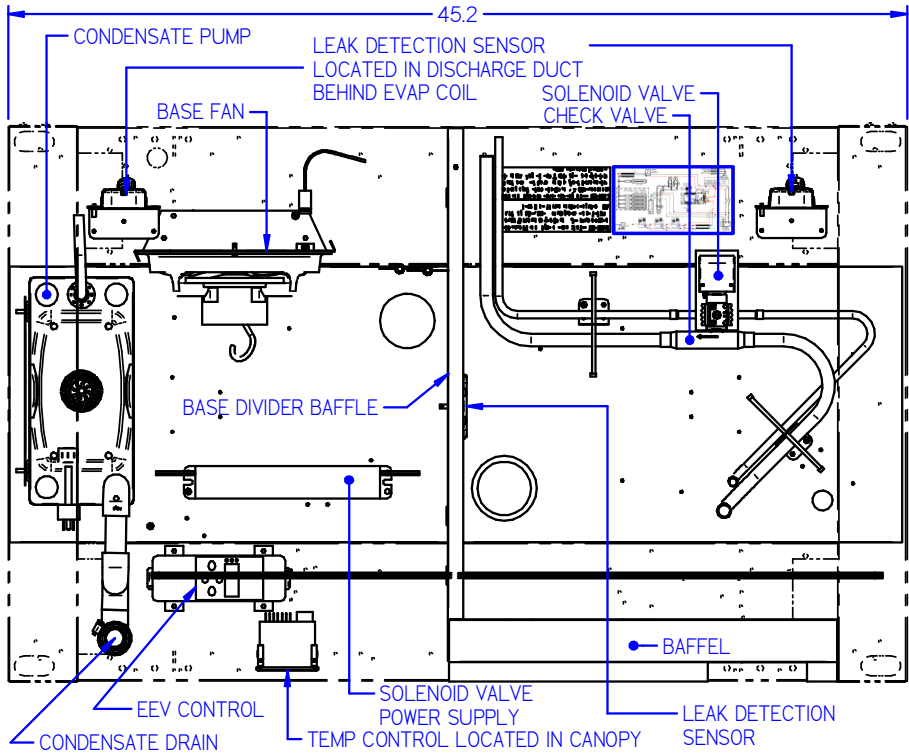

AFTER 11/01/25

VRSS6060/6078 & VRSS7260/7278 REMOTES R454c

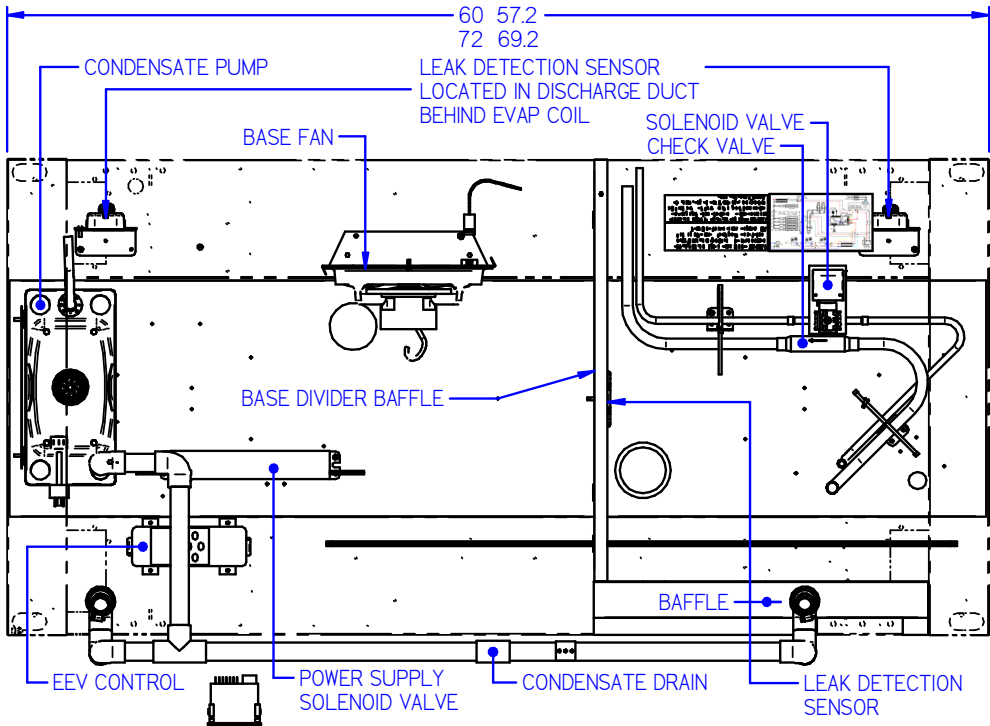

---

## (5) PANEL REMOVAL

---

### 5.1 VRSS & VRSL MODELS

On these models the condenser and condensate pan are in the bottom base compartment. The Front & rear panels can be removed to service and access components.

Disconnect Power before Removing any Panels.

#### Front Panel Removal (VRSS & VRSL):

- Remove center screw from bottom of front panel.
- Lift Front Panel Assembly Up slightly to unhook panel assembly from Key Slots.
- pull bottom of Front Panel outward from under front Valance.
- Reinstall in reverse order, be sure to hook all (4) key slots on panel on to screws.

#### Rear Panel Removal (VRSS & VRSL):

- Remove the rear panel screws located around the perimeter of the Rear Panel.
- Remove rear panel.
- Reinstall in reverse order

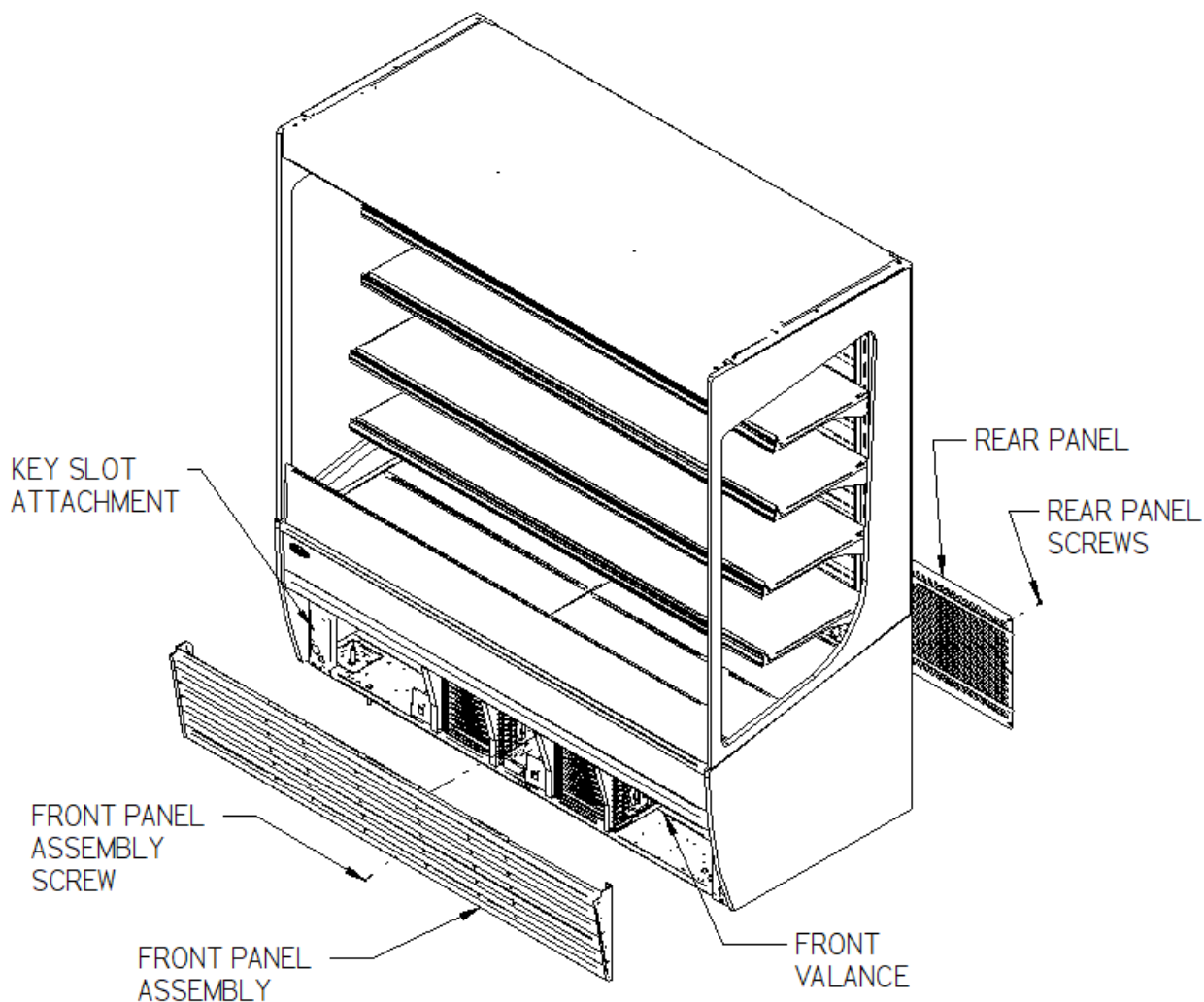

## 5.2 VRSL-MLK MODEL

On the Milk model the condenser is located on the top of the unit and condensate pan is located at the bottom base compartment. The Front & rear panels on top and bottom of case can be removed to service and access components. Disconnect Power before Removing any Panels.

### Front Bottom Panel Removal (VRSL-MLK):

- Remove the center screw from bottom of front panel & the screws located under the top lip.
- Remove bottom front panel, Reinstall in reverse order.

### Rear Bottom Panel Removal (VRSL-MLK):

- Remove the rear panel screws located around the perimeter of the Rear Panel.
- Remove the rear panel along with Fan. Reinstall in reverse order.

### Front Top Panel Removal (VRSL-MLK):

- Remove (2) screws located on each side of top of front panel.
- Lift the Top Front Panel Assembly Up slightly to unhook panel assembly from Key Slots.
- Remove Top Front panel, Reinstall in reverse order.

### Rear Top Panel Removal (VRSL-MLK):

- Remove the top rear panel screws located around the perimeter of the Top Rear Panel.
- Remove rear panel. Reinstall in reverse order

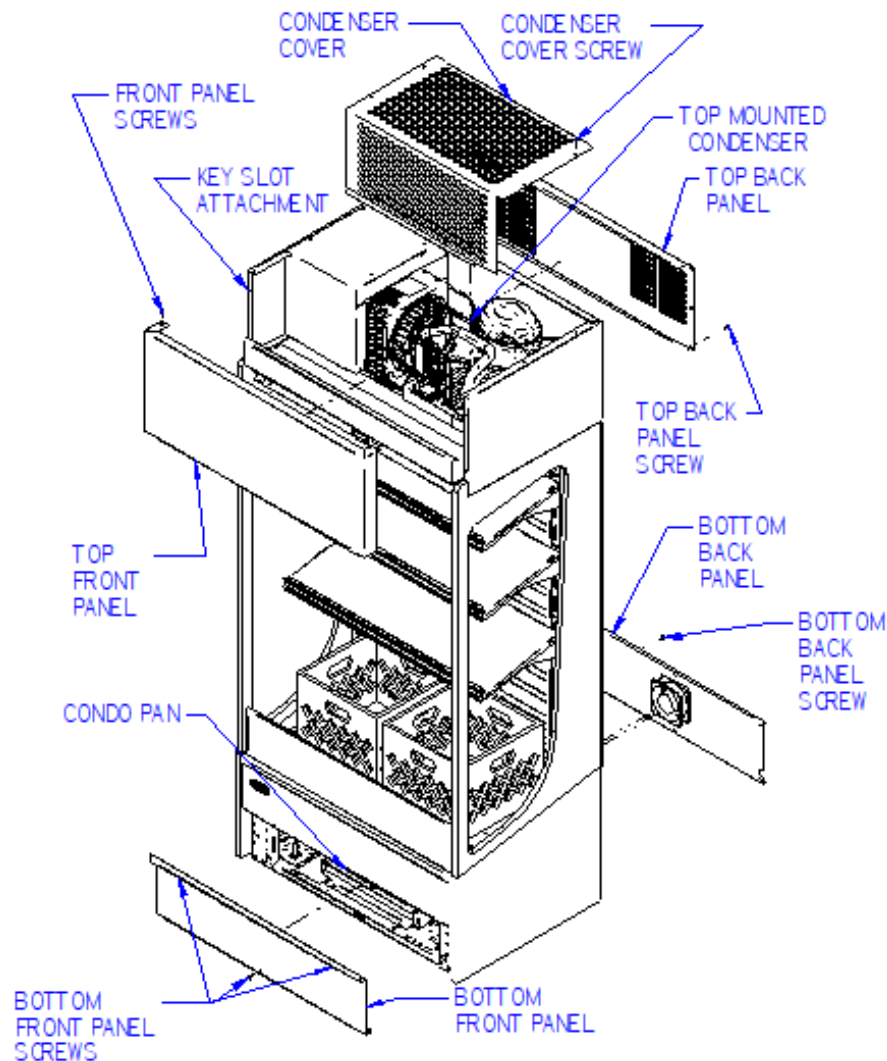

---

---

## (6) PRIOR TO UNPACKING EQUIPMENT!

---

---

### *Inspect for shipping damage.*

You are responsible for filing all freight claims with the delivery truck line. Inspect all cartons and crates for damage as soon as they arrive. If damage is noted to shipping crates, cartons, or if a shortage is found, note this on the bill of lading (all copies) prior to signing.

If damage is discovered when the case is uncrated, immediately call the delivery truck line and follow-up the call with a written report indicating concealed damage to your shipment. Ask for an immediate inspection of your concealed damaged item. Crating material must be retained to show the inspector from the truck line. Installation instructions

**IMPORTANT:** Read this Section of this manual located on page 5.

“REFRIGERATION WARNING & INSTALLATION-REPAIR-DECOMMISSIONING”

All refrigeration and electrical work must be performed by certified technicians.

### 6.1 LOCATING THE DISPLAY CASE

	<p><b>NOTICE</b></p> <p>This refrigerated display case is designed to operate in a maximum environment of 80 DEG. F and 55% relative humidity. Exceeding these limits will cause poor case performance and sweating.</p>
---	--

This case is designed for a class 3 environment.

<u>Test room climate class</u>	<u>Dry bulb temperature [°F]</u>	<u>Relative Humidity [%]</u>	<u>Dew point [°F]</u>	<u>Water vapor mass in dry air [lbm water/lbm air]</u>	<u>Required Test Lab Temperature [°F]</u>
3	77.0	60	62.06	.012	89.6

NSF TYPE 1 Temperature cannot exceed 75 deg F and 55% humidity.

The case(s) should be located where it is not subjected to the direct rays of the sun, heating ducts, grills, radiator, or ceiling fans, nor should it be located near open doors or main door entrances. Also, avoid locations where there is excessive air movement or air disturbances and avoid high humidity locations such as near cases with water misting or fogging devices. Failure to locate this case as stated will reduce the performance of your display and will affect the temperature of interior of case and product.

-Front condenser air in and front air out cases require 2” between the back of case and the wall and 2” from top to ceiling to allow air circulation. Failure to give adequate space may cause poor performance and exterior surfaces to sweat.

-Rear condenser air in and rear air out cases require open area with a minimum of 3’ between the back of case and the wall and 18” from top to ceiling to allow air circulation. Failure to give adequate space may cause poor performance and exterior surfaces to sweat.

-Front condenser air in and rear air out cases (discontinued 10/1/25) require 12” between the back of case and the wall and 18” from top to ceiling to allow air circulation. Failure to give adequate space may cause poor performance and exterior surfaces to sweat.

The maximum releasable charge may be required to comply with local codes. This must be calculated for the complete system as follows:

$$M_{rel} = \text{Maximum Releasable Charge}$$

$$M_{rel} \text{ of Federal Product} + M_{rel} \text{ of condensing unit} + M_{rel} \text{ of line set}$$

The table below shows various maximum releasable charge values for line sets.

		Liquid Line Maximum Releasable Line Charge By Length							
		1/4" (6.35mm)		3/8" (9.53)		1/2" (12.7mm)		1" (25.4mm)	
Line Length [ft]	Line Length [m]	lbs	kg	lbs	kg	lbs	kg	lbs	kg
10	3.0	0.6	0.3	0.8	0.4	1.1	0.5	0.6	0.3
50	15.2	1.1	0.5	2.1	1.0	3.5	1.6	1.1	0.5
100	30.5	1.8	0.8	3.8	1.7	6.5	3.0	1.8	0.8
250	76.2	3.8	1.7	8.8	4.0	15.6	7.1	3.8	1.7

		Suction Line Maximum Releasable Line Charge By Length							
		1/2" (12.7mm)		5/8" (15.9mm)		3/4" (19.1mm)		7/8" (22.2)	
Line Length [ft]	Line Length [m]	lbs	kg	lbs	kg	lbs	kg	lbs	kg
10	3.0	1.0	0.4	1.3	0.6	1.7	0.8	2.2	1.0
50	15.2	3.1	1.4	4.8	2.2	6.8	3.1	9.2	4.2
100	30.5	5.8	2.6	9.2	4.2	13.2	6.0	17.9	8.1
250	76.2	13.9	6.3	22.3	10.1	32.4	14.7	44.1	20.1

## 6.2 REMOVING CASE FROM SHIPPING SKID

Be sure to leave shelf packaging material intact for this step.

First remove the base front and rear panels

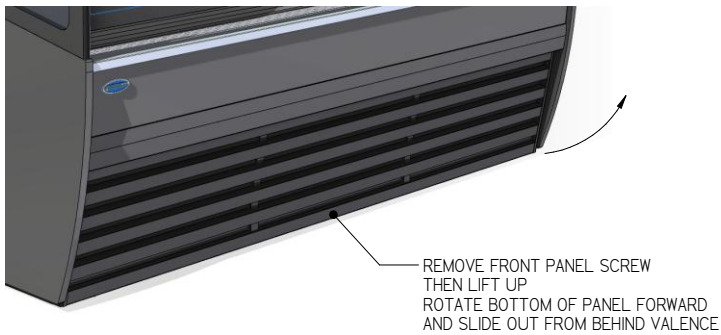

Two or more people should be involved in moving the unit from the pallet onto the ground.

Remove the (4) 1/4" screws that secure the case to the skid. These screws are in the front and rear corners of the base rails. Base front and rear panels must be removed to access these bolts.

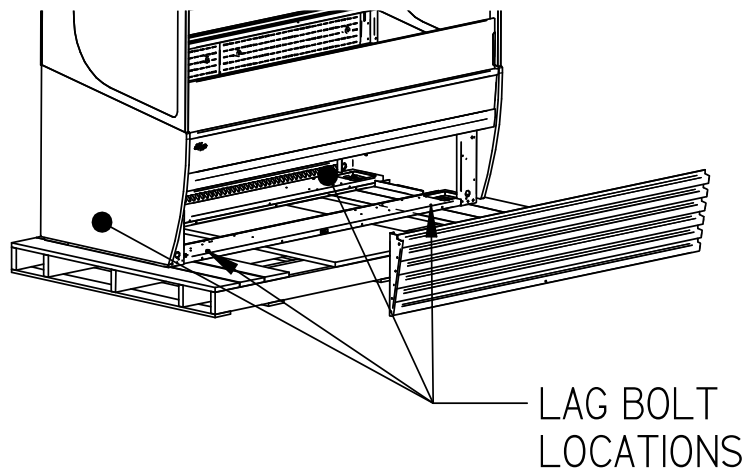

Once all the bolts are removed, slide the unit off the back of the shipping pallet, and tilt it so the rear corner touches the ground. Someone must move the pallet out from under the case and gently tilt the case forward until it touches the floor.

NOTE: see page 20 for removal of slide-in cases from pallet

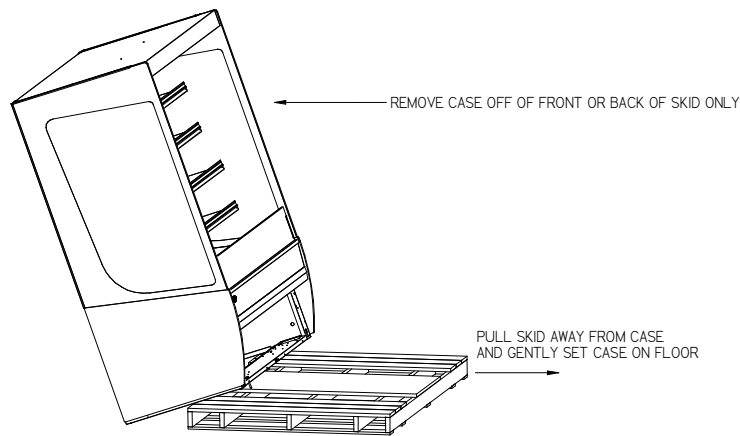

### 6.2.1 Removing Packaging Material

Remove bubble wrap and packing material for all shelves and panel, brackets, etc. If it is necessary to remove tape residue from plastic materials, use cleaning compounds recommended in the cleaning section of this manual. "Lifting and Moving the Case"



**Caution:**

**Do not push or pull against the glass air deflector on front of case. Doing so can cause the glass to break. Do not push or pull on the side glass or pull on the base panel. Doing so will break glass or pull out the panel mounting screws. Care must be taken not to damage the case when removing it from the skid or moving the case.**

### 6.3 SINGLE CASE INSTALLATION (STAND ALONE UNITS)

#### Leveling the Case

It is important that the case is level. This will allow for proper drainage of condensate water from evaporator coil. A wrench is included to aid in adjusting the leg levelers.

Check the left-to-right level of the case along front of plastic air deflector retainer.

Check the front-to-rear level of the case along the interior ends of the case.

LEVEL CASE USING THESE SURFACES

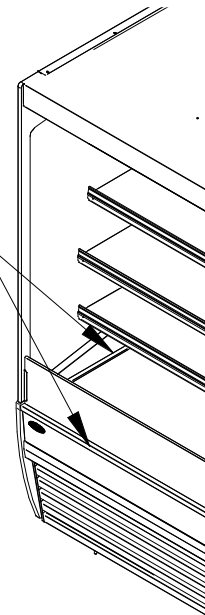

Adjust the (4) outside leg levelers as needed to level the case in each direction.

NOTE: If necessary, use a wood or plastic shim under each leg leveler to avoid scratching the tile floor.

#### Sealing Unit to The Floor

After the unit is positioned and the leg levelers are turned out, the unit needs to be sealed to the floor for NSF approved installation.

### 6.4 INSTALLATION FOR JOINED CASES (LINEUPS)

#### 6.4.1 Join refrigerated to refrigerated

1. Remove all Shelves, display deck, interior back panel(s), exterior back(s), front and rear base panel, and loosen honeycomb (see cleaning section for honeycomb removal) material on the unfinished end to expose the holes used to bolt units together.
2. Position the right or left most unit in the desired position for the lineup to start, and level this case.
3. Push the 2<sup>nd</sup> case next to the 1<sup>st</sup> and line them up as closely as possible.
4. Adjust the leveling legs of the 2<sup>nd</sup> case until the units and joining holes align with each other.
- 5.
6. Using (7) holes noted below, bolt units together with the supplied hardware, and attach joining trim to remove the gap between the decks in the joined units. Re-use the screws in the uprights, as well as the self-drilling screws provided with the kit.

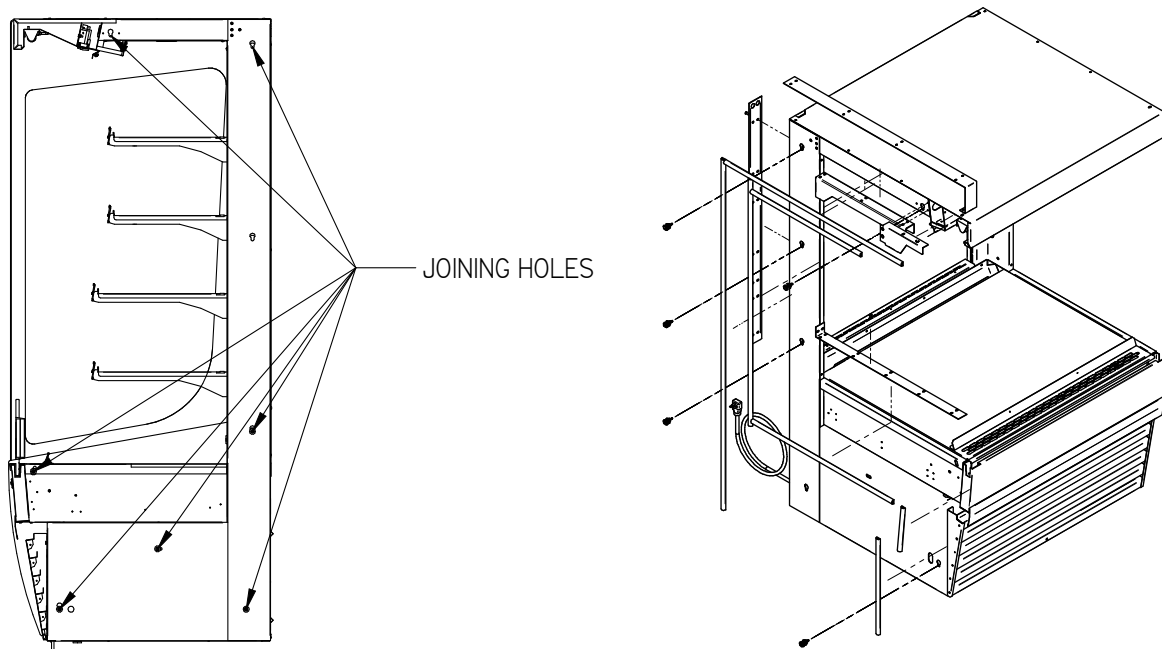

7. Replace all panels that were previously removed and re-insert honeycomb

#### 6.4.2 Join units with glass divider, or join refrigerated too non-refrigerated

For this joining configuration, one unit will come with a lower end panel preinstalled with glass. Five bolt holes will be exposed on the outside of this panel and are the locations that will be used to join the units together. This kit also comes with top and rear exterior trim, but no interior trim.

1. Remove all Shelves, display deck, interior back panel(s), exterior back(s), front and rear base panel, and loosen honeycomb (see cleaning section for honeycomb removal) material on the unfinished end to expose the holes used to bolt units together.
2. Position the right or left most unit in the desired position for the lineup to start, and level this case.
3. Push the 2<sup>nd</sup> case next to the 1<sup>st</sup> and line them up as closely as possible.
4. Adjust the leveling legs of the 2<sup>nd</sup> case until the bolt holes align with the mating holes in the joining case.
5. Push the units together so that the bolts go through the case to be joined.
6. Using the hardware provided (1/4-20 screw, washer, lock washer), screw the 2<sup>nd</sup> case with the unfinished end into the first case.

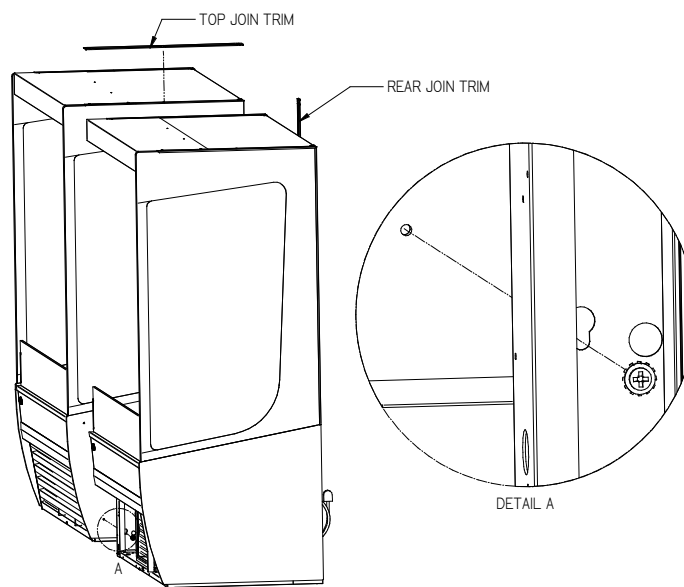

7. Finish the joining process by loosening the glass trim on the case to slide the joining trim over the existing trim and secure with the existing fasteners. Do this for both the top trim and the rear trim.

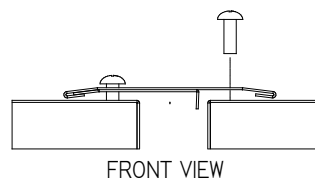

8. Replace any panels previously removed. Units are now joined.

## 6.5 INSTALLATION IN AN ALCOVE

When installing a case in an alcove make sure any signage above the case is sealed to prevent airflow from returning into the case.

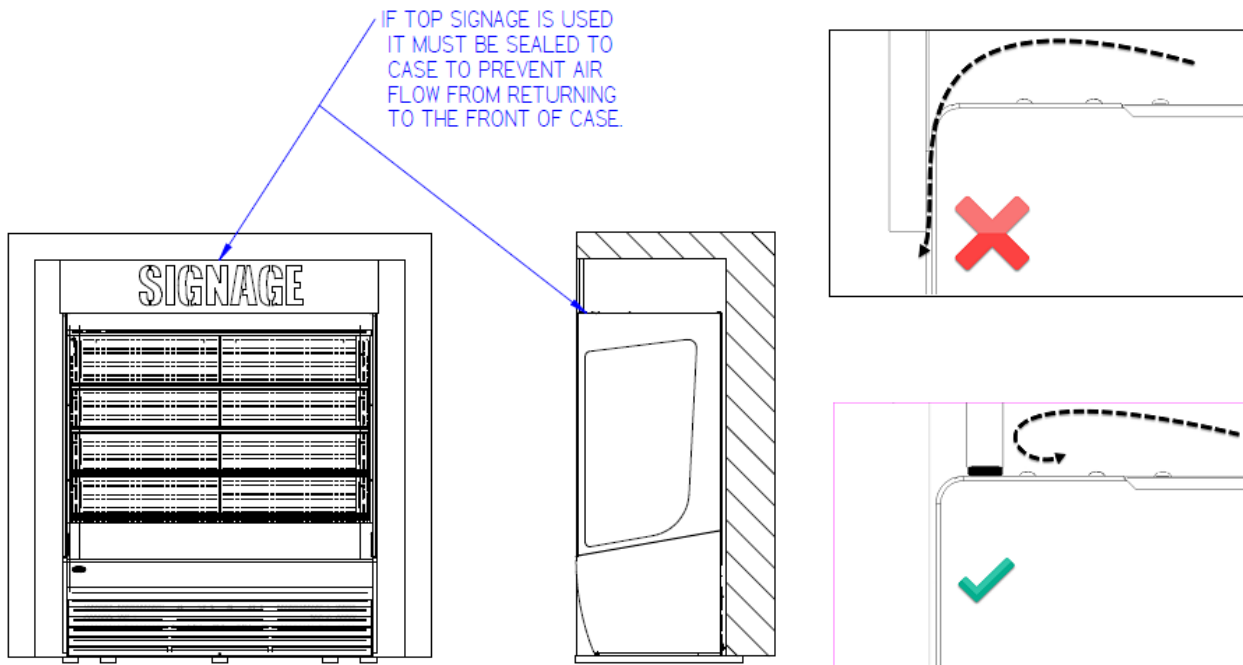

## (7) SHELF INSTALLATION AND REMOVAL

### Shelf brackets and supports



#### **NOTICE: Improper shelf configuration will cause performance issues**

**VRSS 78in tall units have two different shelf depths. The lower two shelves are longer, the upper two to three shelves are shorter. The longer shelves must be installed as the lowest shelves or the unit's air curtain will be disrupted and the unit will not maintain product temperature.**

Shelves are pre-installed in the factory. To change shelf positions, remove the shelf, then shelf support, then brackets. Relocate the brackets to the desired shelf position. The left bracket and right bracket must be at the same height. This can be ensured by counting the position of the notch in the shelf standard. If you have shelf lights, the wire running to the light must be unplugged prior to moving the shelves. Note how the wire runs through the shelf support, and shelf.

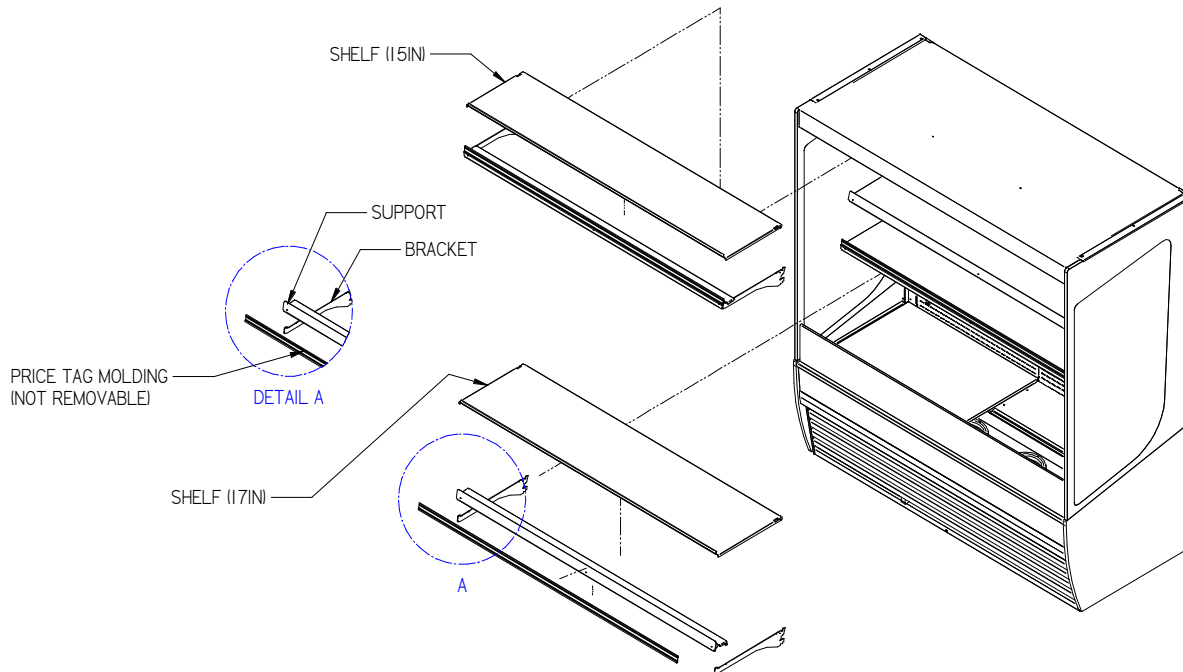

The diagram below illustrates how to straighten or angle the shelves. To angle the bracket, be sure to have the top hook of the bracket in its slot and to pull up while rotating down to the most extreme downward position. To angle the shelf, first angle both brackets, and install the shelf as normal.

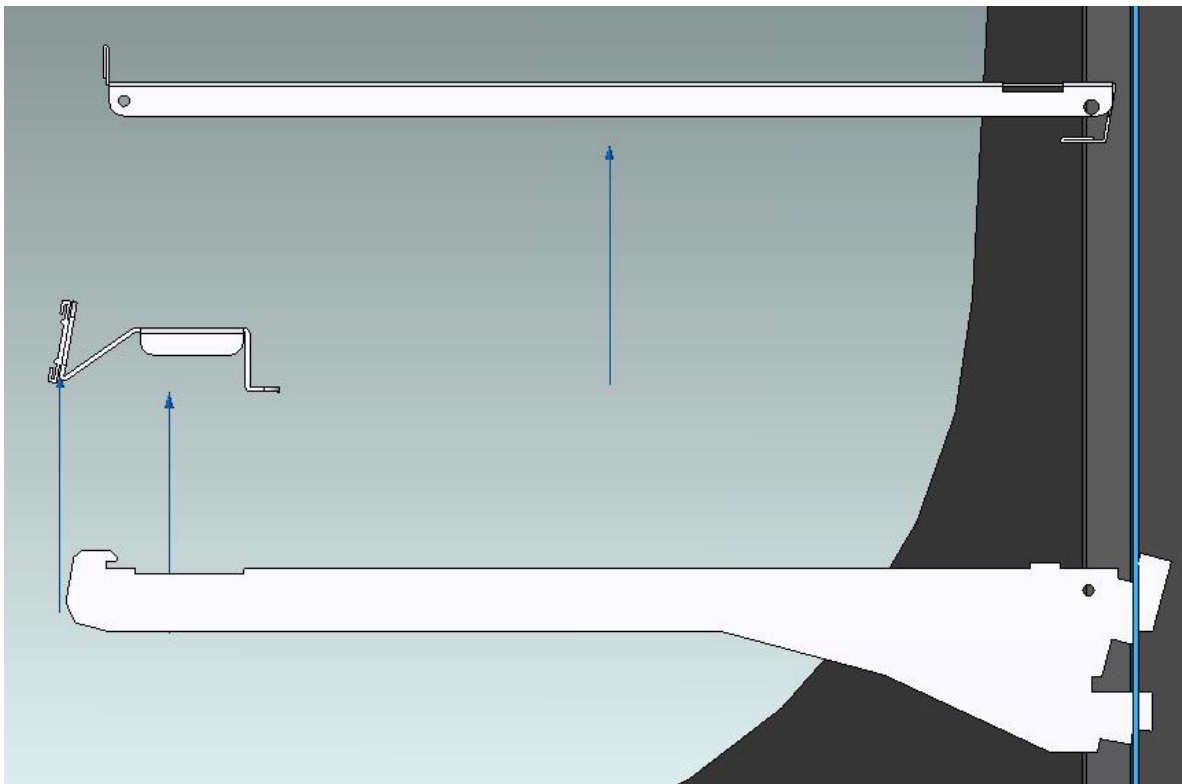
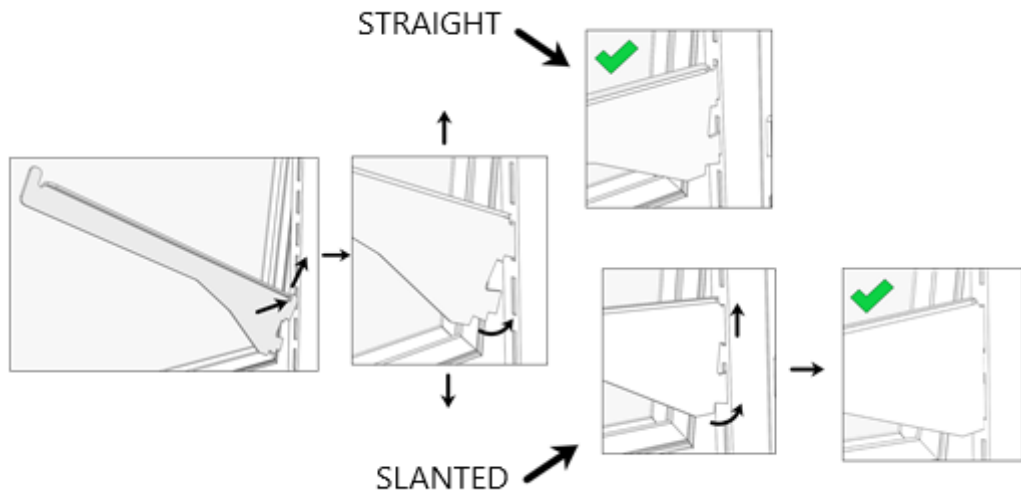

## INSTALLING SHELF LIGHT CORDS

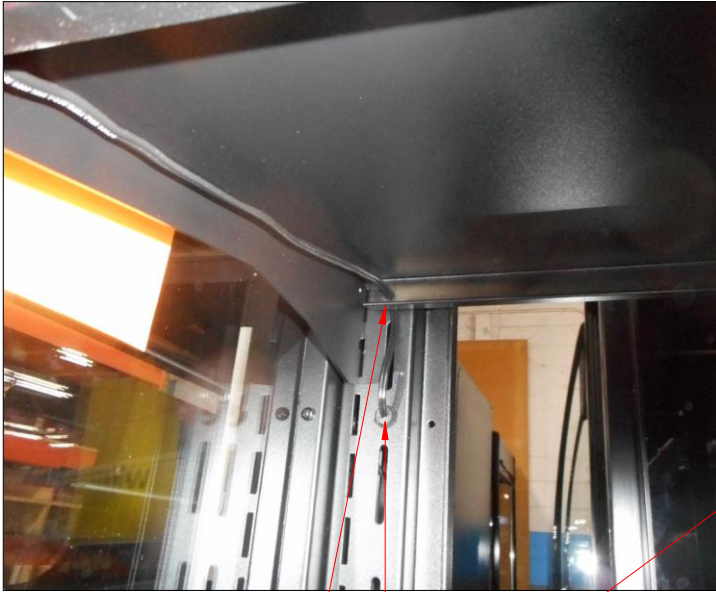

CORD HOOKS IN SLOT ON  
BACK FLANGE OF SHELF

PUSH EXCESS SHELF CORD  
BACK INTO GROMMET

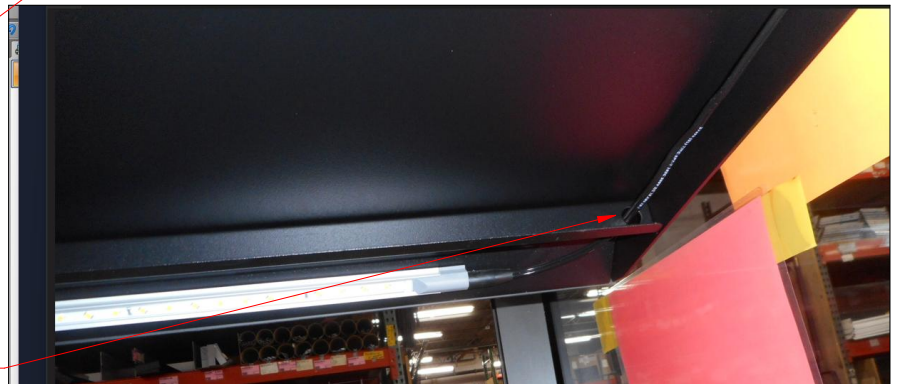

CORD GOES THRU HOLE IN SHELF SUPPORT

## (8) SECURITY NIGHT COVER (OPTIONAL)

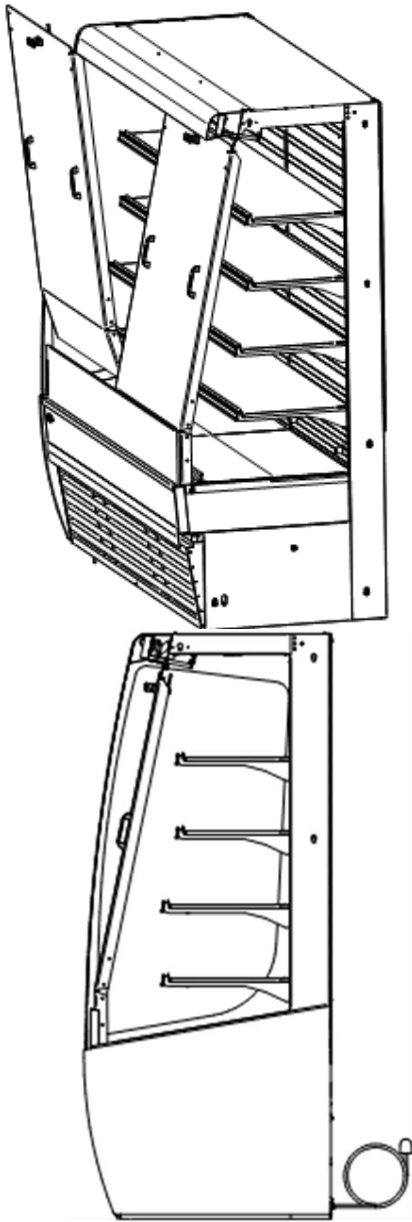

1. Install the security cover into the preinstalled retaining brackets by first inserting the bottom with the top of the cover tilted out.
2. Insert the bottom of the security cover into the lower u-clip retainer by rotating the top of the assembly toward the case and dropping the cover down into place.
3. The top of the cover will sit against the upper retainer bracket.
4. Once the cover is in position, lock the latch using the key in the t-handle of the security cover panel.

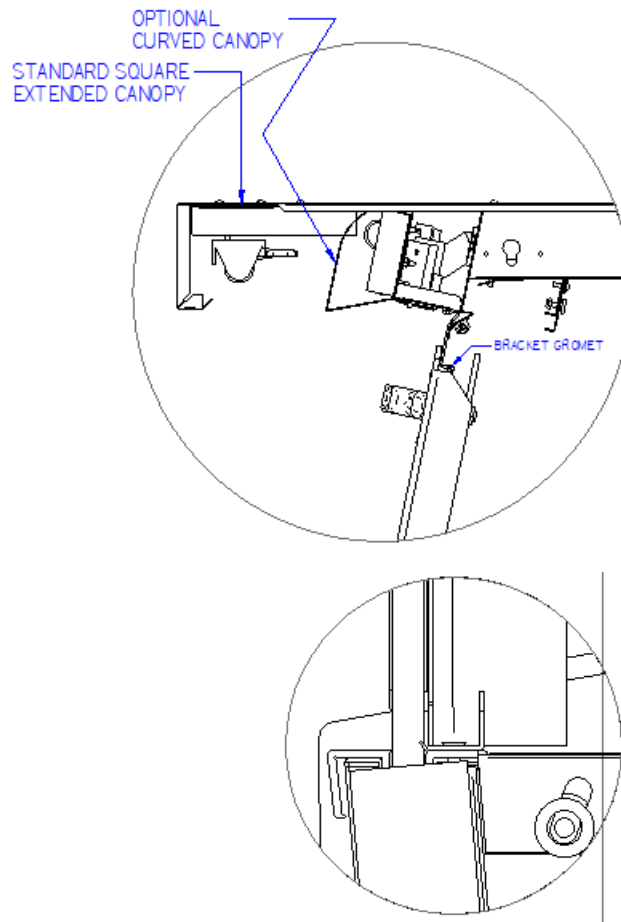

When installing the security cover panel, ensure that the bottom of the panel is seated in the lower u-clip, and that the latch fully engages behind the upper retaining bracket.

5. Install the security cover into the preinstalled retaining brackets by first inserting the bottom with the top of the cover tilted out.
6. Insert the bottom of the security cover into the lower u-clip retainer by rotating the top of the security cover assembly in toward the case and dropping the cover down into place.
7. The top of the cover will sit against the upper retainer bracket.  
Once the cover is in position, lock the latch using the key in the t-handle of the security cover panel.

---

## (9) Slide-In Models -Leg & Caster Adjustments

---

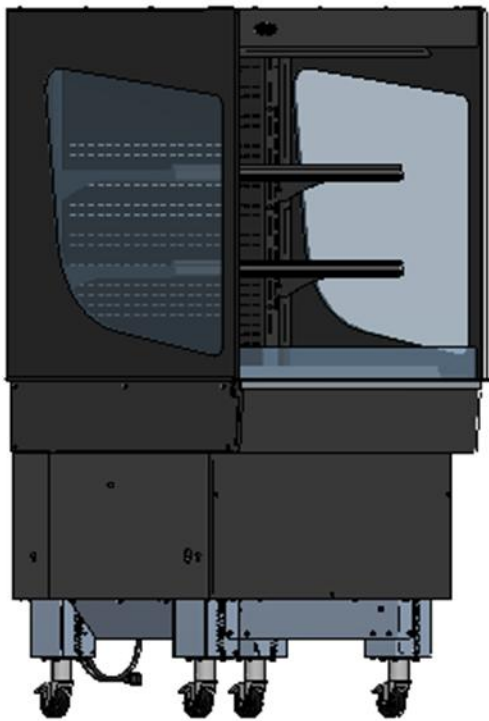
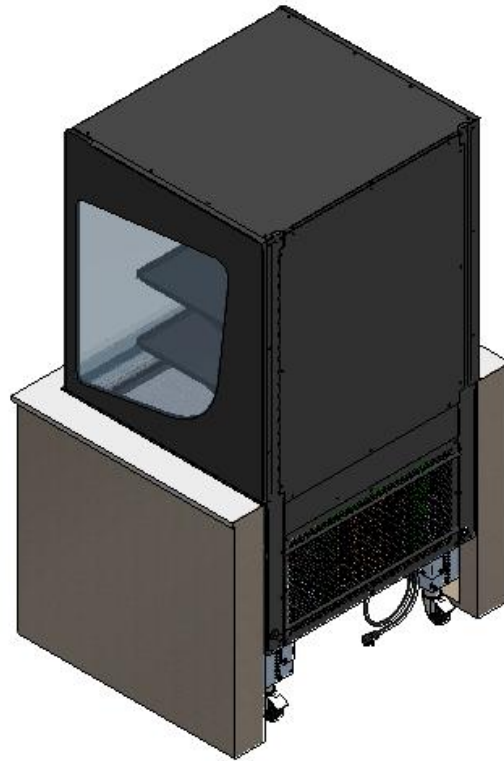
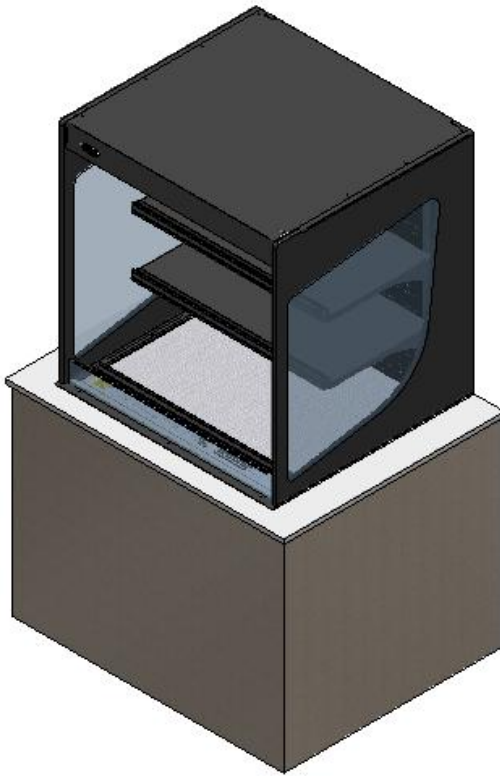

### Slide In Models

Designed to slide/roll into a counter with an open back.

Refrigerated cases are available with rear condenser air intake and discharge only.

Case counter height is set at 34" from the factory.

Leg assemblies are adjustable in 1/4" increments.

Adjustable casters have 1" of upward adjustment to fine tune height to match counter surfaces.

Casters lock in the swivel and roll directions.

The next page shows common counter height adjustments.

**\*\*\*IMPORTANT\*\*\***

**CASE MUST BE LIFTED AND SECURED TO ADJUST CASTER/LEG ASSEMBLIES.**

**\*\*\*WARNING\*\*\***



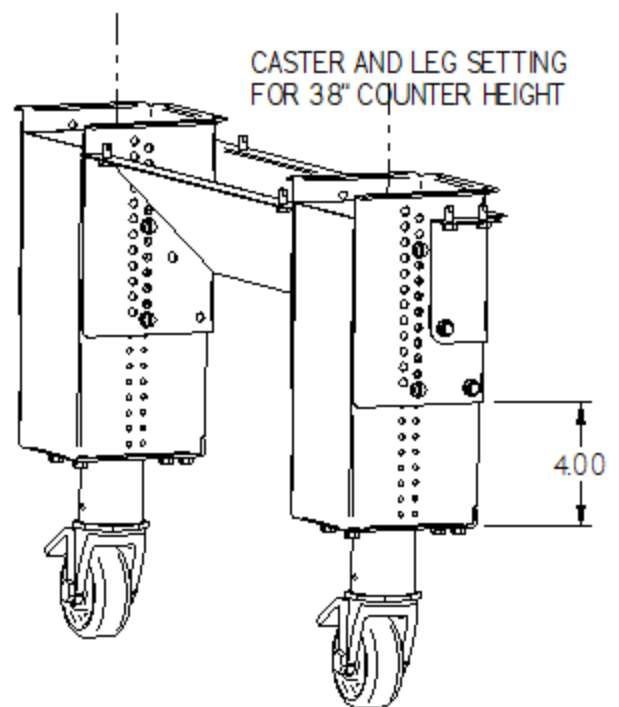
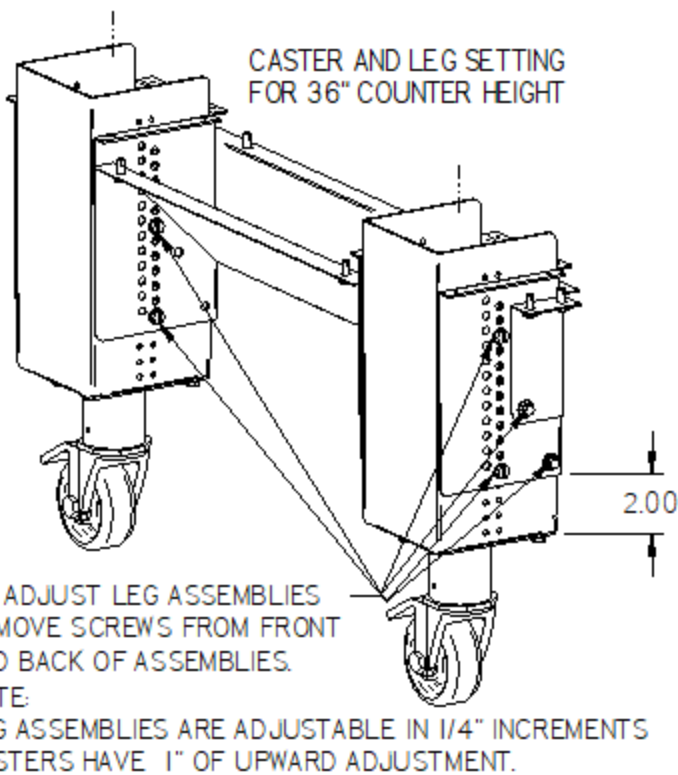
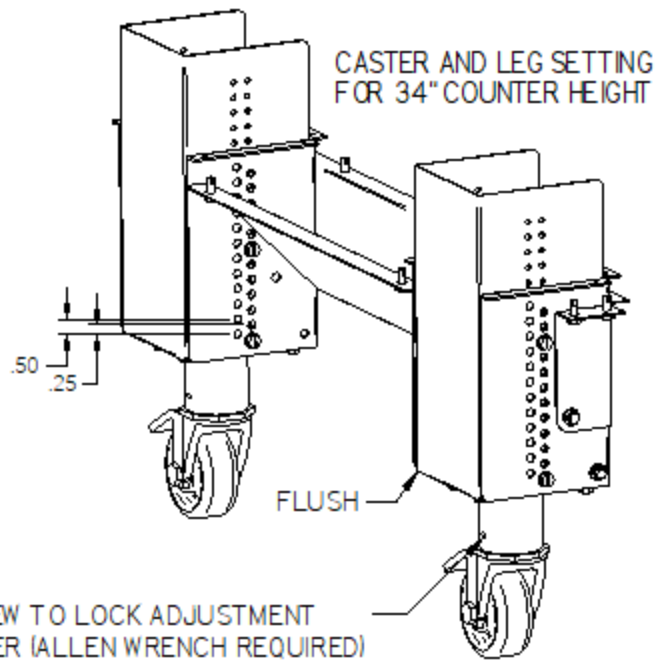
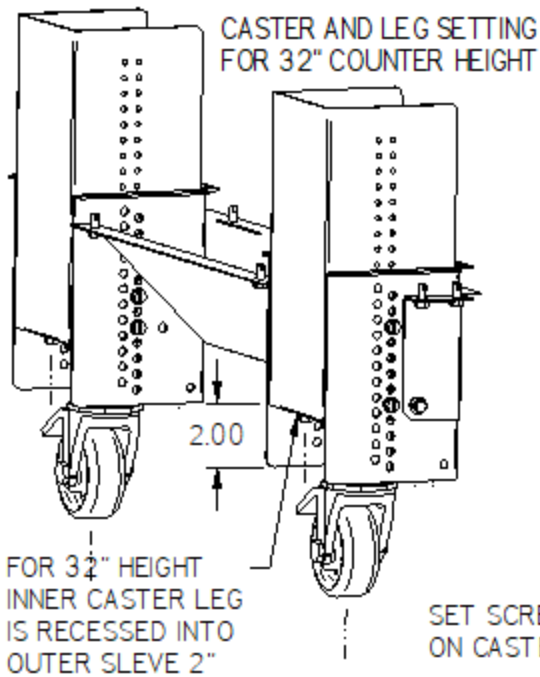

**FAILURE TO DO SO CAN CAUSE SEVERE INJURY OR DEATH.**



\*\*\*IMPORTANT\*\*\*  
CASE MUST BE LIFTED AND SUPPORTED WHEN ADJUSTING CASTER LEG ASSEMBLIES.  
\*\*\*WARNING\*\*\*  
FAILURE TO DO SO CAN CAUSE INJURY OR DEATH



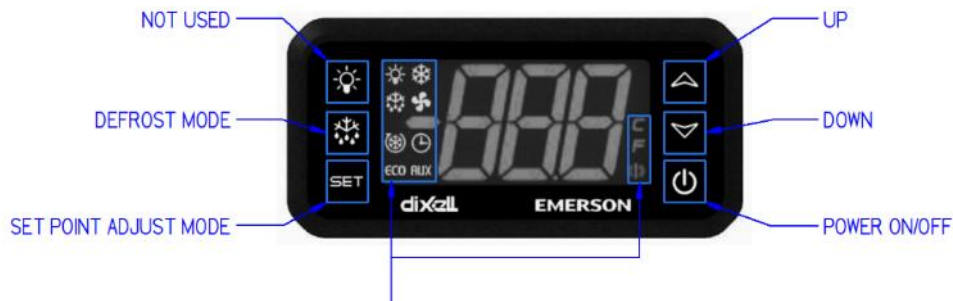

NOTE: some leg adjustment can be done before case is removed from the pallet.

# (10) ELECTRONIC TEMPERATURE CONTROL (REFRIGERATED UNITS ONLY)

	Power on/off: Press and hold to turn system on or off.
<b>SET</b>	Set: Press and hold to enter the set point adjustment menu.
	Defrost: Press and hold to initiate a manual defrost.
	Up: Change set points when in set point adjustment menu. When not in set point menu, shows maximum temperature of the display probe.
	Down: Change set points when in set point adjustment menu. When not in set point menu, it shows minimum temperature of the display probe.



**Display indication symbols**

	On	Compressor on
	Flashing	Minimum compressor off time in progress
	On	Unit in defrost mode
	Flashing	Defrost delay
	On	Condenser fan running
	Flashing	Minimum condenser fan off time in progress
	On	Alarm occurring. See the error code section below.
<b>°C/°F</b>	On	Indicates temperature unit of measure.

### 10.1.1 Powering on control

**To turn refrigeration control power on**, press and hold “⏻” for approx. three seconds. When the control power turns on, the display will read the cabinet probe temperature. The compressor and condenser fan run indicators (\* & ✿) will illuminate on the display, meaning that the compressor and condenser fan are running. (Note: the control may already be in the on mode when shipped from factory).

**To turn refrigeration control power to off**, press and hold “⏻” for approx. three seconds. When the control powers off the display will read “OFF”. When refrigeration control is in the off-mode cabinet lights and evaporator fans will still operate, but the compressor will not turn on causing the case to gradually reach room temperature.

### 10.1.2 Adjusting the set point

The set point is what determines how cold the display case will hold food and beverage. To adjust the set point press the “SET” button. Then press “▲” button to increase the set point number (colder) or press the “▼” button to decrease the set point number (warmer). There are nine (9) available set points numbers, the higher the number of the set point, the colder the display case will run, with setting “9” being the coldest and setting “1” being the warmest. Once you have chosen your desired setting press the “SET” button again to confirm your choice. The control cutout temperature for the selected setpoint will briefly be displayed if the setpoint is changed.

### 10.1.3 Entering manual defrost mode

The control is programmed to automatically initiate a defrost by two different methods, involving time and temperature, as outlined in the “Defrost Cycle” section (Pg.) of “ELECTRONIC CONTROL PARAMETERS AND EXPLANATION OF OPERATION.” While it is uncommon that the automatic defrost cycles would insufficiently defrost the case, a Manual Defrost mode is available if this situation arises.

*Note: The control will not allow the initiation of a manual defrost within 30 minutes of completion of another defrost cycle, manual or automatic.*

To initiate the manual defrost press and hold the “❄️” button approx. three seconds. The defrost is initiated when the defrost mode indicator ❄️ illuminates on the display. The control display will then return to reading the probe temperature. When the defrost mode indicator ❄️ turns off the defrost is complete and the compressor will turn on automatically and the compressor and condenser fan indicator will be shown (\* & ✿).

### 10.1.4 Error codes

It is possible for error codes to be displayed on the control screen. In the event of a malfunction an alarm will sound and the alarm indicator 📢 will be displayed. An error code or codes will flash E3980 VISION R290

intermittently on the display. If there are multiple codes, the display will continuously cycle through them.

Mute: You may mute the alarm by pressing any button. The red alarm symbol  and all error codes will still be displayed. When the fault is remedied, the control will return to normal operation and will automatically clear the codes from the display.

<u>Display</u>	<u>Description</u>	<u>Cause</u>	<u>Resolution</u>
"P1"	Air discharge temperature probe failure	Probe signal is interrupted or short-circuited	<ul style="list-style-type: none"> <li>• Check to ensure probe wires and quick disconnect are secure in control.</li> <li>• Check probe resistance to table below. If 0 resistance is present, check wiring insulation. If infinite resistance is present, check for breaks in wiring (meter will likely read overload or very high in the mega-ohm range).</li> <li>• Ensure that probes are wired per the wiring diagram provided. Replace probe if other remedies fail, or if probe resistance deviates from "Table 3" below.</li> </ul>
"P2"	Defrost temperature probe failure		

<b>TEMPERATURE PROBE COMMON RESISTANCE CHART</b>			
<b>Probe Temp</b>	<b>Maximum Resistance [kΩ]</b>	<b>Normal Resistance [kΩ]</b>	<b>Minimum Resistance [kΩ]</b>
<b>32°F(0°C)</b>	27.83	27.28	26.74
<b>77°F(25°C)</b>	10.1	10	9.9
<b>212°F(100°C)</b>	1	0.97	0.94

# (11) REFRIGERATION OPERATION

## 11.1.1 Remote Models

REFRIGERATED MODEL	ELECTRICAL	SELF CONTAINED					REMOTE AFTER 11/01/25					
		STANDARD CONNECTION CORD & PLUG			REFRIGERANT	CONDENSATE REMOVAL	PERMANENT CONNECT		REFRIGERANT	BTU'S @ + 20°	CONDENSATE REMOVAL	
		AMPS	MAX FUSE SIZE	NEMA CORD &			AMPS	MAX FUSE				
VRSS3660S, VRSS3660C, VRSL3660S, VRSS3678s, VRSS3678C, VRSL3678S, VRSL3683S-MLK	120/60/1	16	20	NEMA 5-20P	R290	INTEGRATED PAN	N/A	N/A	N/A	N/A	N/A	
VRSS4860S, VRSS4860C, VRSL4860S, VRSS4878s, VRSS4878C, VRSL4878S	208-240/60/1	11	15	NEMA 6-15P	R290	INTEGRATED PAN	3.0	15	R454c	9,580	PUMP	
VRSS6060S, VRSS6060C, VRSL6060S, VRSS6078s, VRSS6078C, VRSL6078S	208-240/60/1	16	20	NEMA 6-20P	R290	INTEGRATED PAN	3.5	15	R454c	11,200	PUMP	
VRSS7260S, VRSS7260C, VRSL7260S, VRSS7278s, VRSS7278C, VRSL7278S	208-240/60/1	16	20	NEMA 6-20P	R290	INTEGRATED PAN	3.5	15	R454c	12,300	PUMP	

The remote models are designed to use R454c refrigerant and shipped from the factory with the evaporator coil, expansion valve, sight glass, and refrigerant solenoid valve. Filter Drier must be installed in field. Electronic control runs identical to the self-contained models except the electronic control opens and closes a refrigeration solenoid valve located on the suction line instead of turning on and off a compressor. The solenoid valve closes and shuts off the refrigeration flow to the unit and initiates a pump down cycle. This will allow the remote low-pressure switch to open and shut off remote compressor.

The condensing unit is optionally supplied from the factory for remote location installation. The condensing unit must be mounted and wired by the installer.

1. Mount condensing unit indoors as close to the remote display case as practical. The refrigeration line should be as short as possible and must not exceed 30 feet.
2. All refrigeration and/or electrical materials between the condensing unit and display case are to be supplied by installing contractor.
3. Route properly sized and designed refrigeration lines from the condensing unit to the cabinet.
4. Horizontal suction lines should be pitched downward towards the condensing unit at least 1/2" per 10' run to aid the oil drainage. A "P" trap must be installed in the suction line at the foot of every riser to insure oil return. Dry nitrogen must be used to flow through tubing while brazing refrigeration lines.
5. Suction line must be insulated the entire length with Armaflex (or equivalent). Do not run liquid line inside insulation with suction line.
6. The remote high/low-pressure control must be mounted, wired and set pressures by the installer.
7. Leak check condensing unit, cabinet, and all connecting tubing. Cabinet and condensing unit tubing should be checked to insure no leaks occurred during shipping or from rough handling.
8. Make certain all refrigeration valves are opened and evacuate system to 500 microns. Charge the system with refrigerant type specified on the data plates.

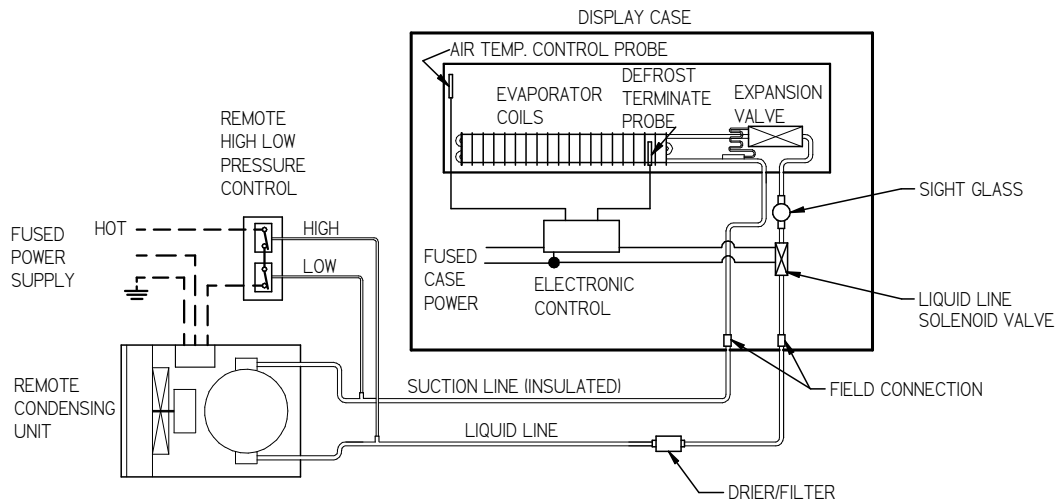

**Figure 1 - Remote Refrigeration Diagram**

## **Electronic Expansion Valve (EEV)**

A traditional TXV uses springs and a temperature bulb to open and close a valve port that controls the flow of refrigerant entering the evaporator coil. An electronic expansion valve (EEV) controls the refrigerant flow much more precisely, increasing the performance and efficiency of the refrigeration system. The EEV controls the flow of Refrigerant by opening and closing the valve port based on the response to signals sent to the EEV by an electronic controller. The electronic Control bases these signals by processing information provided from a temperature sensor and pressure transducer located on the discharge side of the evaporator coil.

These sensors monitor the evaporator superheat and protects the compressor from any liquid flood back under low superheat conditions.

## **EEV Controller Settings**

The electronic expansion valve controller also allows the use of different types of refrigerants without the need to change the expansion valve.

The controller is set from the factory to run on R454C refrigerant (code 45C) and will not need any changes to the control unless another refrigerant is used.

**Note:** on units with older model EEV'S, the EEV is set to code 40C.

**Note: Check your State and Local regulations for approved refrigerants for your install location. Federal Industries is not liable for any alternate refrigerants used.**

The control is located in the base.

**Note: Never change any of the other setting other than the refrigerant type. It may also be necessary to change the superheat setting only when using a different refrigerant.**



Indicator lights	
	Red light - critical alarm (system is NOT running)
	Yellow light - non-critical alarm (system running)
	Green light - compressor on
	Green blinking - compressor waiting on timer to start/stop

### Changing Refrigerant

- Access the set point mode by pressing and holding the **ENTER** button until Ctl displays on the screen.
- Use the up or down arrows to advance through the available set points until rFG displays on the screen and press the **ENTER** button.
- Use the up or down arrows until the desired refrigeration displays on the screen and press and hold the **ENTER** button until rFG once again displays on the screen.
- Press the **BACK** to return to escape the settings menu.

### Changing Superheat

- Access the set point mode by pressing and holding the **ENTER** button until Ctl displays on the screen.
- Use the up or down arrows to advance through the available set points until SSP displays on the screen and press the **ENTER** button.
- Use the up or down arrows to set the desired superheat displays on the screen and press and hold the **ENTER** button until SSP once again displays on the screen.

Press the **BACK** to return to escape the settings menu.

## **11.2 REMOTE UNITS THERE ARE SPECIAL REQUIREMENTS FOR A2L REFRIGERANTS SUCH AS R454C**

Piping material, pipe routing, and installation shall include protection from physical damage in operation and service, and be in compliance with national and local codes and standards, such as ANSI/ASHRAE 15, IAPMO Uniform Mechanical Code, ICC International Mechanical Code, or CSA B52. All field joints shall be accessible for inspection prior to being covered or enclosed

The installation of pipe work shall be kept to a minimum.

Federal remote units are charged with dry nitrogen only. Joints made in the installation where any part is precharged shall be made in accordance with the following:

- a) A brazed, welded or mechanical connection shall be made before opening the valves to permit refrigerant to flow between the refrigerating system parts. A vacuum valve shall be provided to evacuate the interconnecting pipe and/or any uncharged refrigerating system part.
- b) Mechanical connectors used indoors shall comply with ISO14903 or UL 207 or CSA C22.2 No.140.3. When mechanical connectors are reused indoors, sealing parts shall be renewed. When flared joints are reused indoors, the flare part shall be refabricated.
- c) Refrigerant tubing shall be protected or enclosed to avoid damage. Flexible refrigerant connectors (such as connecting lines between the indoor and outdoor unit) that might be displaced during normal operation shall be protected against mechanical damage.

Mechanical connections shall be accessible for maintenance purposes.

E3980 VISION R290

Provisions shall be made for expansion and contraction of long runs of pipes. Protection devices, piping, and fittings shall be protected as far as possible against adverse environmental effects, for example, the danger of water collecting and freezing in relief pipes or the accumulation of dirt and debris.

Piping in refrigeration systems shall be designed and installed to minimize the likelihood of hydraulic shock damaging the system

Do not use steel refrigeration lines with Federal products.

Flexible pipe elements shall be protected against mechanical damage, excessive stress by torsion, or other forces, and that they should be checked for mechanical damage annually.

Precautions shall be taken to avoid excessive vibration or pulsation. Use vibration dampening tubing clamps as necessary, especially near sources of vibration.

This unit requires a minimum room area size to operate in. See table below for minimum room areas

This Chart Is For Remotes Only

Model	A <sub>min</sub> [sq meters]	A <sub>lim</sub> [sq ft]
VRSL4860	14	150
VRSL4878	14	150
VRSL6060	19	200
VRSL6078	19	200
VRSL7260	19	200
VRSL7278	19	200
VRSS3660	10	110
VRSS3678	10	110
VRSS4860	14	150
VRSS4878	14	150
VRSS6060	19	200
VRSS6078	19	200
VRSS7260	19	200
VRSS7278	19	200

After completion of field piping for split systems, the field pipework shall be pressure tested with dry nitrogen and then vacuum tested prior to refrigerant charging according to the following requirements:

- 1) The minimum test pressure for the low side of the system shall be the low side design pressure and the minimum test pressure for the high side of the system shall be the high side design pressure, unless the high side of the system cannot be isolated from the low side of the system in which case the entire system shall be pressure tested to the low side design pressure. See the unit data plate for applicable pressures.
- 2) The test pressure after removal of pressure source shall be maintained for at least 1 h with no decrease of pressure indicated by the test gauge, with test gauge resolution not exceeding 5 % of the test pressure.
- 3) During the evacuation test, after achieving a vacuum level of 250 microns or less, the refrigeration system shall be isolated from the vacuum pump, and the pressure shall not rise above 500 microns within 10 min. The vacuum pressure level shall be the lessor of 500 microns or the value required for compliance with national and local codes and standards, which may vary between residential, commercial, and industrial buildings.

Always follow local codes during installation.

Be sure that any refrigeration line running through an occupied space is protected against damage by using line set covers, sleeving, etc. As little line set as possible should be run through an occupied space. Run refrigeration line sets through building floors, ceilings, walls, or mechanical rooms as much as possible. Be sure to follow all local codes.

The maximum releasable charge may be required to comply with local codes. This must be calculated for the complete system as follows:

$$M_{rel} = \text{Maximum Releasable Charge}$$

$$M_{rel} \text{ of Federal Product} + M_{rel} \text{ of condensing unit} + M_{rel} \text{ of line set}$$

The table below shows various maximum releasable charge values for line sets.

		Liquid Line Maximum Releasable Line Charge By Length							
		1/4" (6.35mm)		3/8" (9.53)		1/2" (12.7mm)		1/4" (6.35mm)	
Line Length [ft]	Line Length [m]	lbs	kg	lbs	kg	lbs	kg	lbs	kg
10	3.0	0.6	0.3	0.8	0.4	1.1	0.5	0.6	0.3
50	15.2	1.1	0.5	2.1	1.0	3.5	1.6	1.1	0.5
100	30.5	1.8	0.8	3.8	1.7	6.5	3.0	1.8	0.8
250	76.2	3.8	1.7	8.8	4.0	15.6	7.1	3.8	1.7

		Suction Line Maximum Releasable Line Charge By Length							
		1/2" (12.7mm)		5/8" (15.9mm)		3/4" (19.1mm)		7/8" (22.2)	
Line Length [ft]	Line Length [m]	lbs	kg	lbs	kg	lbs	kg	lbs	kg
10	3.0	1.0	0.4	1.3	0.6	1.7	0.8	2.2	1.0
50	15.2	3.1	1.4	4.8	2.2	6.8	3.1	9.2	4.2
100	30.5	5.8	2.6	9.2	4.2	13.2	6.0	17.9	8.1
250	76.2	13.9	6.3	22.3	10.1	32.4	14.7	44.1	20.1

---

## (12) REFRIGERANT DETECTION AND MITIGATION SYSTEM

---

The refrigerant detection system (RDS) shuts down the operation of the refrigerator when a leak is detected. The system is comprised of 2 or more sensors, a low voltage power supply, 1-2 safety shutoff solenoid valves, and 1-2 refrigerant check valves.

When a leak is detected by one of the sensors, the internal sensor relay opens to shut off the safety solenoid valve(s). The refrigeration check valve prevents any back flow from the rest of the external system from entering the unit that would further contribute to a leak.

The sensor is equipped with an LED status light, indicating the Refrigerant Detection System's status, as shown below:



Please note that once a leak is detected and the flow of refrigerant is stopped, the display case will stop cooling, and any temperature sensitive products must be removed from the unit.

This display case's fans are a part of the leak mitigation system and are required to remain powered on as long as there is power to the display case. In the event of a refrigerant leak, the unit's fans are required to run to reduce the concentration of flammable refrigerant in and around the unit. When replacing gas detection sensors, only replace with the original model of sensor provided by Federal.

To replace a faulty sensor, simply remove unplug the electrical quick connection and unscrew the sensor fasteners and attach the new sensor to the original sensor location in the original orientation.

After replacing installing the new sensor, power on the display case. After a few seconds, the sensor light will begin to blink green. See illustration above. The refrigeration system will be allowed to run as normal.

The sensor is capable of a long life and will monitor its condition to ensure functionality. If the sensor's self-monitoring system detects an issue it will go into a fault state and shut off the flow of refrigerant to the appliance. See above illustration for fault indication on LED.

The gas inlet exposes the sensing element of the sensor to surrounding gases. The opening in the sensor housing exposes the humidity and temperature sensors inside the sensor to the environment and makes them susceptible to pollutants such as volatile chemicals, acids, bases, cleaning and foaming agents. Exposure to those pollutants should be avoided. Cleaning products might damage the sensor or temporarily block its gas inlet, inhibiting or delaying the response to the refrigerant.

The use of solvent emitting materials near the sensor, such as PVC cement glues, may lead to nuisance trips. Solvent emitting materials can lead to high concentrations of volatile gas in the nearby environment. The gas sensor may sense these concentrations, and trigger a system mitigate response. Please note that the safety shut-off valve system is installed at the factory. No safety shut-off valves are required to be installed in the field on new equipment.

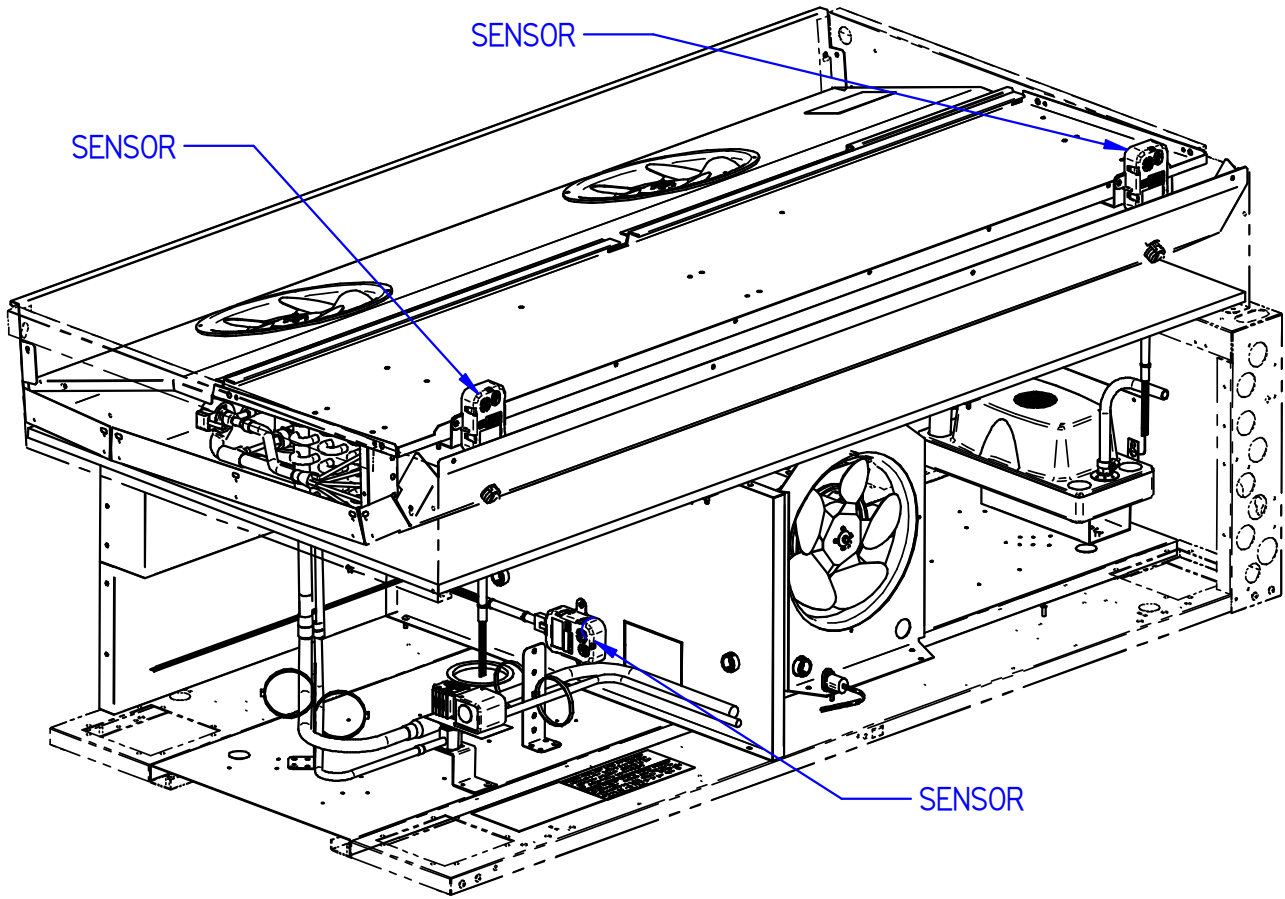

## (13) INITIAL STARTUP (REFRIGERATED UNITS ONLY)



### NOTICE

This refrigerated display case is designed to operate in a maximum environment of 80 DEG. F and 55% relative humidity. Exceeding these limits will cause poor case performance and sweating.

1. Prior to initial startup be sure to clean the case as described in the “Weekly Cleaning” section of the manual.
2. Be sure that the display deck(s) and shelves are in the desired locations.
3. Be sure front and rear base panels are in place and secured.
4. Plug in the unit to the appropriate wall outlet and turn unit’s power switch (marked “POWER”) to the on or “I” position.
5. If the control reads “OFF” then press and hold the control’s power button to turn it on.
6. In a few moments the refrigeration system will turn on.
7. Use the switch labeled “LIGHT” to turn on all top/shelf lights.

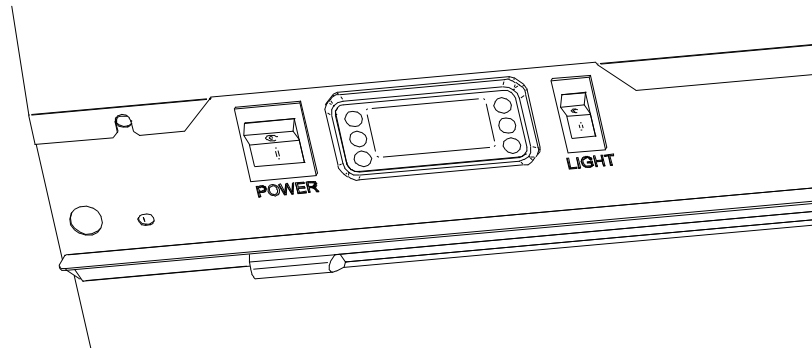

For more detailed information on control operation see the section “Electronic Temperature Control”

At start up from a warm unit, it is recommended that the temperature control is set to a mid-setting, such as 5. After the unit has gone through several cycles, adjust the control to a warmer or colder setting, if necessary, to maintain desired product temperature. Allow refrigerated models to run for at least two hours before placing pre-chilled product into display area.

### 13.1.1 Placing Product into Case



### NOTICE

**CASE MUST BE STOCKED WITH PRE-CHILLED PRODUCT 38° OR COLDER.**

- Do not exceed 150 pounds of weight per shelf. Heavy products should be distributed evenly across the entire shelving area.
- Determine desired shelving location before placing product in case. Product must be removed to readjust shelf location.
- Do not overhang the front or rear of the shelves with product. Improper clearance in front and rear of the shelf will block the refrigerated airflow and will cause product loss.
- Do not block the slots along the front and rear air discharge slots. Covering these slots will block the refrigerated airflow and could cause product loss. Allow refrigerated models to run for at least two hours before placing pre-chilled (38°F or less) product into the case.
- Allow a minimum of 0.5" between the top of product and bottom of next shelf up to allow proper air flow around product. Also allow a minimum of 1 in between top of product and ceiling.
- Allow 1 in of space between product and end glass.
- Product on the rear of shelves and deck should allow for 1 inch of rear clearance to the interior back panel.

## **Condensate Evaporator**



**NOTICE: Steam from the condensate evaporator may be visible around the base of the merchandiser during normal operation.**

This merchandiser is furnished with an electric condensate evaporator, and no plumbing connections are required.

If the merchandiser is supplied with either an electric condensate pump or floor drain option, the hose inside case will need to be routed to the nearest drain.

If desired the condensate drain tubes can be changed to bypass the condensate system and run directly to drain. Bypassing the Factory condensate system must be performed by a qualified plumber and electrician.

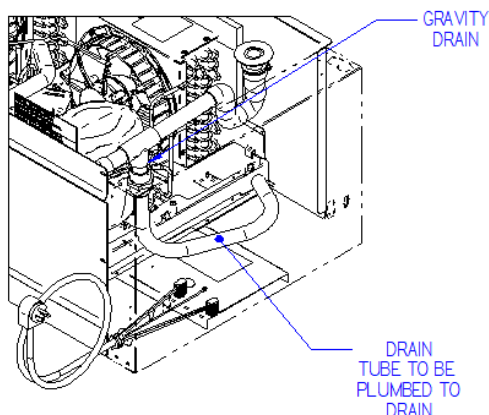
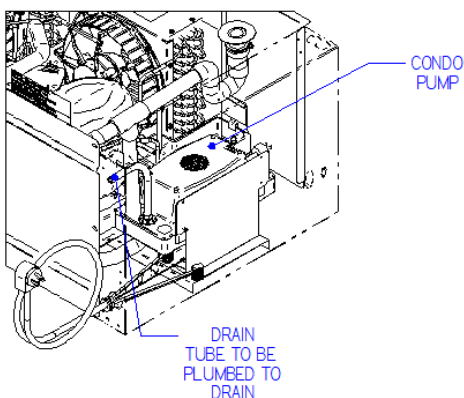

This is an open merchandiser and can produce a large amount of condensate water.

To ensure that adequate evaporator capacity is available, a high wattage heater is used.

Inspect condensate pan and drain tubes to be sure nothing has become dislodged during shipment and that nothing is leaking. Tightening or adjusting clamps or hoses may be required.





---

# (14) CLEANING INSTRUCTIONS

---

## 14.1 DAILY CLEANING

The case should be cleaned thoroughly, as described in the weekly cleaning section before it is used for the first time.

	<p><b>NOTICE:</b> Avoid splashing or soaking any electrical components with water to prevent electrical damage to the case.</p>
	<p><b>NOTICE:</b> Shut off lights, disconnect power and remove all products from case. Allow sufficient time for the unit to reach room temperature before proceeding with cleaning.</p>
	<p><b>NOTICE:</b> Remove all products from the case before proceeding with cleaning procedure.</p>
	<p><b>NOTICE:</b> This case is not designed to be cleaned by flushing.</p>





**Note:** For major spills or foreign material buildup perform the weekly cleaning instructions.

**Note:** Detergents are not recommended and do not use abrasive cleaners or pads to prevent scratching of surfaces.

1. Clean all foreign materials from the door opening.
2. Completely wipe the interior of both the upper & lower areas of case using a damp cloth.
3. The remaining exterior surface should be wiped down using any ammoniated cleaners or soapy warm water.

## 14.2 WEEKLY CLEANING

This procedure is recommended on a weekly basis. It may need to be performed more often if necessary to maintain a clean, sanitary case. The case should be cleaned to the following procedure before using case for the first time.

	<p><b>NOTICE:</b>  Avoid splashing or soaking any electrical components with water to prevent electrical damage to the case.</p>
	<p><b>NOTICE:</b>  Shut off lights, disconnect power and remove all products from case. Allow sufficient time for the unit to reach room temperature before proceeding with cleaning.</p>
	<p><b>NOTICE:</b>  Remove all products from the case before proceeding with cleaning procedure.</p>
	<p><b>NOTICE:</b>  This case is not designed to be cleaned by flushing.</p>

1. Side, and rear door glass can be cleaned with common window cleaners.
2. Remove interior shelving and display deck from unit as described in the “Shelving Installation and Removal” section of this manual.
3. Clean all shelves, shelf supports, shelf light deflectors, shelf brackets, shelf standards using warm soapy water and a brush. Rinse thoroughly and allow it to dry.
4. Remove the display deck and clean using warm soapy water and a brush. Rinse thoroughly and allow it to dry.
5. Clean the entire interior of the case using warm soapy water. Wipe off all soapy water with a damp cloth and allow it to dry. (DO NOT use solvents such as Acetone, Benzene, Carbon Tetrachloride, and Lacquer Thinners)
6. Reassemble all components in reverse order.
7. The exterior surfaces should be wiped down using any ammoniated cleansers or warm soapy water.

### 14.3 CLEANING CONDENSER COIL



#### **NOTICE:**

**Condenser coil must be inspected/cleaned at regular intervals defined below to ensure proper refrigeration performance and prevent compressor failure. In some environments, it may be necessary to clean more frequently. FAILURE TO CLEAN CONDENSER COIL WILL VOID COMPRESSOR WARRANTY.**

The condenser must be cleaned from the front of the case.

1. Disconnect power to the unit.
2. Depending on the model, remove either the front panels located on the base or Top Rear panel to expose condenser fins.
3. Carefully vacuum the front surface of condenser coil. Take care not to bend coil fins with vacuum cleaner nozzle.
4. Reinstall all panels and retaining screws and reconnect power.

#### 14.3.1 Standard Condenser fan

It is very important that the Condenser coil is cleaned twice monthly to ensure proper refrigeration performance and to prevent compressor failure. Failure to clean condenser coil will void condenser warranty. ***In environments where deep fat fryers and grills are used, a short cleaning schedule may be necessary. This may require the use of a no rinse coil cleaning agent.***

#### 14.3.2 Optional Self-cleaning Reversing fan

In models equipped with the Self-Cleaning reversing fan option, Federal recommends the coil should be inspected and cleaned within ***1 month from initial install*** and inspected and cleaned a minimum of every 3 months. Cleaning frequency may need to be adjusted, based on the findings of each inspection. ***In environments where deep fat fryers and grills are used, a shorter cleaning schedule may be necessary. This may require the use of a no rinse coil cleaning agent.***

The procedure for cleaning a unit equipped with the reversing fan is the same as the above procedure for the standard condenser fan.

See last page of manual for condenser coil cleaning and inspection form.

---

## (15) SERVICE

---

**IMPORTANT:** Read this Section of this manual located on page 5.  
“REFRIGERATION WARNING & INSTALLATION-REPAIR-DECOMMISSIONING”  
All refrigeration and electrical work must be performed by certified technicians.

### Service Information

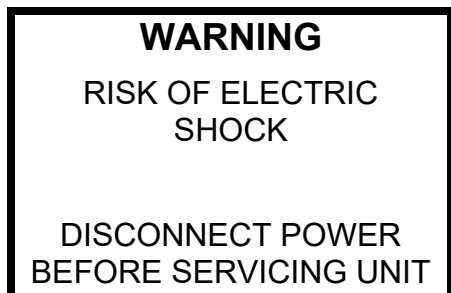

**Before any service work is performed  
on the case, make sure all power is  
disconnected to the case.**

**To find a service company in your area, please visit our website at  
<https://federalind.com/support-service/service-rep-locator>. There you can also find self-  
service tools to help you get the answers you need faster!**

For warranty service requests and all technical support, including compressors and other service parts please contact:

- Phone: (833) 238-8168
- Email: [techservice@partstown.com](mailto:techservice@partstown.com)



Federal Industries has partnered with Parts Town for ALL Non-Warranty Part Identification, Pricing, Lead Times, Orders & Freight Quotes. Please contact Parts Town directly if you need parts:

- Website: [Partstown.com](http://Partstown.com)
- Email: [CustomerService@Partstown.com](mailto:CustomerService@Partstown.com)
- Phone: 833-809-8188

---

---

## **(16) SALE & DECOMMISSIONING**

---

---

**IMPORTANT:** Read this Section of this manual located on page 5.  
“REFRIGERATION WARNING & INSTALLATION-REPAIR-DECOMMISSIONING”  
refrigeration and electrical work must be performed by certified technicians

All

### **OWNER RESPONSIBILITY**

If you sell or give away your Federal Industries case, you must make sure that all safety labels and the Installation-Service Manual are included with it. If you need replacement labels or manuals, Federal Industries will provide them free of charge. Contact the customer service department at Federal Industries at (800) 356-4206.

The customer service department at Federal Industries should be contacted at the time of sale or disposal of your case so records may be kept of its new location. Electrical and refrigeration specs

If you sell or give away your Federal Industries case, you should evacuate the refrigerant charge before shipment.

### **Refrigerant Recovery/Recycling/Disposal**

When recycling or discarding case, refrigerants **MUST BE** handled according to local, state and federal codes, requirements and regulations.

If disposing of a refrigerated case that uses ozone depleting chemicals in its refrigeration system, make sure the refrigerant is removed by a qualified service technician and properly disposed of.

If you intentionally release refrigerant into the atmosphere, you may be subject to fines or other penalties (under regulation mandated by environmental regulators and/or legislative edict.)

# (17) ELECTRICAL AND REFRIGERATION SPECS



## WARNING:

Improper or faulty hookup of electrical components in the display case can result in severe injury or death.

**IMPORTANT:** Read this Section of this manual located on page 5.  
 “REFRIGERATION WARNING & INSTALLATION-REPAIR-DECOMMISSIONING”  
 All refrigeration and electrical work must be performed by certified technicians

### Cord Connected

All standard models are supplied with a power cord that is properly sized to the amperage requirements of the case. See the rating plate for specific unit requirements. This can be located as shown in the “FEATURE IDENTIFICATION” section of this manual.  
 The cord is factory installed protruding from the bottom rear corner of the case.  
 A separate circuit for each display case is required to prevent other appliances on the same circuit from overloading the circuit and causing malfunction.

REFRIGERATED MODEL	ELECTRICAL	SELF CONTAINED					REMOTE AFTER 11/01/25				
		STANDARD CONNECTION CORD & PLUG			REFRIGERANT	CONDENSATE REMOVAL	PERMANENT CONNECT		REFRIGERANT	BTU'S @ + 20°	CONDENSATE REMOVAL
		AMPS	MAX FUSE SIZE	NEMA CORD &			AMPS	MAX FUSE			
VRSS3660S, VRSS3660C, VRSL3660S, VRSS3678s, VRSS3678C, VRSL3678S, VRSL3683S-MLK	120/60/1	16	20	NEMA 5-20P	R290	INTEGRATED PAN	N/A	N/A	N/A	N/A	N/A
VRSS4860S, VRSS4860C, VRSL4860S, VRSS4878s, VRSS4878C, VRSL4878S	208-240/60/1	11	15	NEMA 6-15P	R290	INTEGRATED PAN	3.0	15	R454c	9,580	PUMP
VRSS6060S, VRSS6060C, VRSL6060S, VRSS6078s, VRSS6078C, VRSL6078S	208-240/60/1	16	20	NEMA 6-20P	R290	INTEGRATED PAN	3.5	15	R454c	11,200	PUMP
VRSS7260S, VRSS7260C, VRSL7260S, VRSS7278s, VRSS7278C, VRSL7278S	208-240/60/1	16	20	NEMA 6-20P	R290	INTEGRATED PAN	3.5	15	R454c	12,300	PUMP

NON-REFRIGERATED DRY MODEL	ELECTRICAL	STANDARD CONNECTION CORD & PLUG			REMOTE BEFORE 11/01/25				
		AMPS	MAX FUSE SIZE	NEMA CORD &	PERMANENT CONNECT		REFRIGERANT	BTU'S @ + 20°	CONDENSATE REMOVAL
					AMPS	MAX FUSE			
VNSS3660S, VNSS3660C, VNSS3678S, VNSS3678C	120/60/1	1.5	15	NEMA 5-15P	2.5	15	R449A	6,720	PUMP
VNSS4860S, VNSS4860C, VNSS4878S, VNSS4878C	120/60/1	1.5	15	NEMA 5-15P	3.0	15	R449A	9,580	PUMP
VNSS6060S, VNSS6060C, VNSS6078S, VNSS6078C	120/60/1	2	15	NEMA 5-15P	3.5	15	R449A	11,200	PUMP
VNSS7260S, VNSS7260C, VNSS7278S, VNSS7278C	120/60/1	2	15	NEMA 5-15P	3.5	15	R449A	12,300	PUMP



## **CAUTION**

**Risk of Electric Shock. If the cord or plug becomes damaged, replace only with a cord and plug of the same type.**

### **Cord Connected (STANDARD)**

- A factory installed power cord is properly sized to the amperage requirements of the case. See the electrical data plate located on the rear exterior of the case for the proper circuit size for each case.
- The cord is factory installed protruding from the rear corner of the case.
- A separate circuit for each display case is required to prevent other appliances on the same circuit from overloading the circuit and causing malfunction.

### **Refrigerated Permanent Connected (REMOTE REFRIGERATED MODELS ONLY)**

**IMPORTANT:** Read this Section of this manual located on page 5.

**“REFRIGERATION WARNING & INSTALLATION-REPAIR-DECOMMISSIONING”**

All refrigeration and electrical work must be performed by certified technicians

- Only a licensed electrician must perform all case electrical connections.
- All electrical wiring hookups must be done in accordance with all applicable local, regional, or national electrical standards.
- A separate circuit for each display case is required to prevent other appliances on the same circuit from overloading the circuit and causing malfunction.
- The electrical service must be grounded upon installation.
- See the electrical data plate located at the rear of the case for proper circuit size and wire ampacity.
- The electrical connection box is accessible from the rear of the case with rear grill removed. See grill removal section of this manual for grill removal procedure.

# (18) WIRING DIAGRAM

## 18.1 VRSS SELF CONTAINED R290

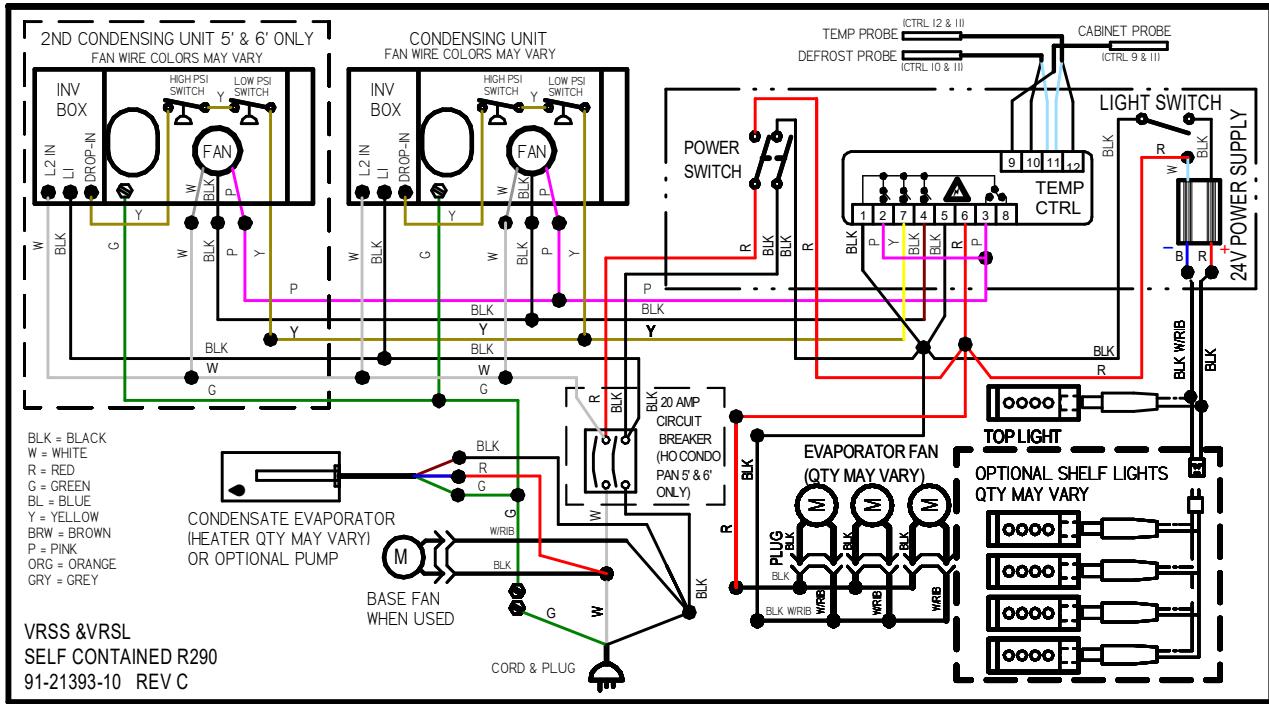

## 18.2 VRSS REMOTE

BEFORE 11/01/25

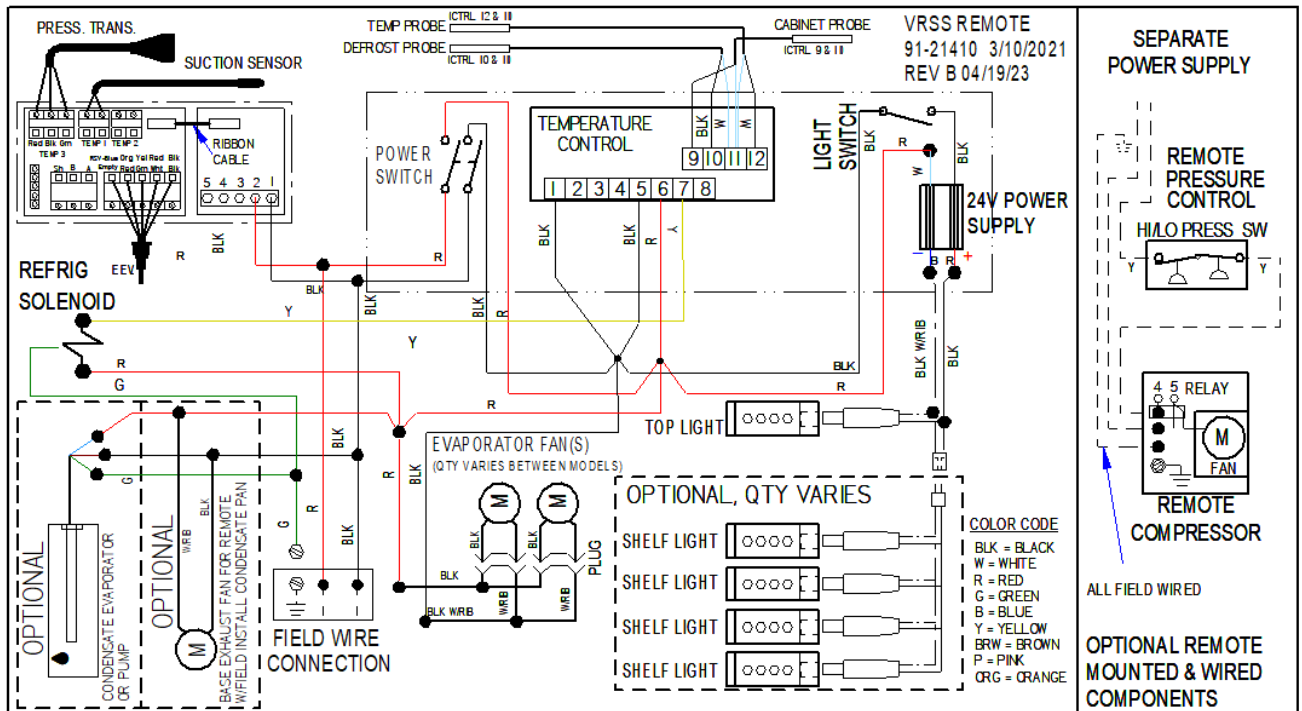

AFTER 11/01/25

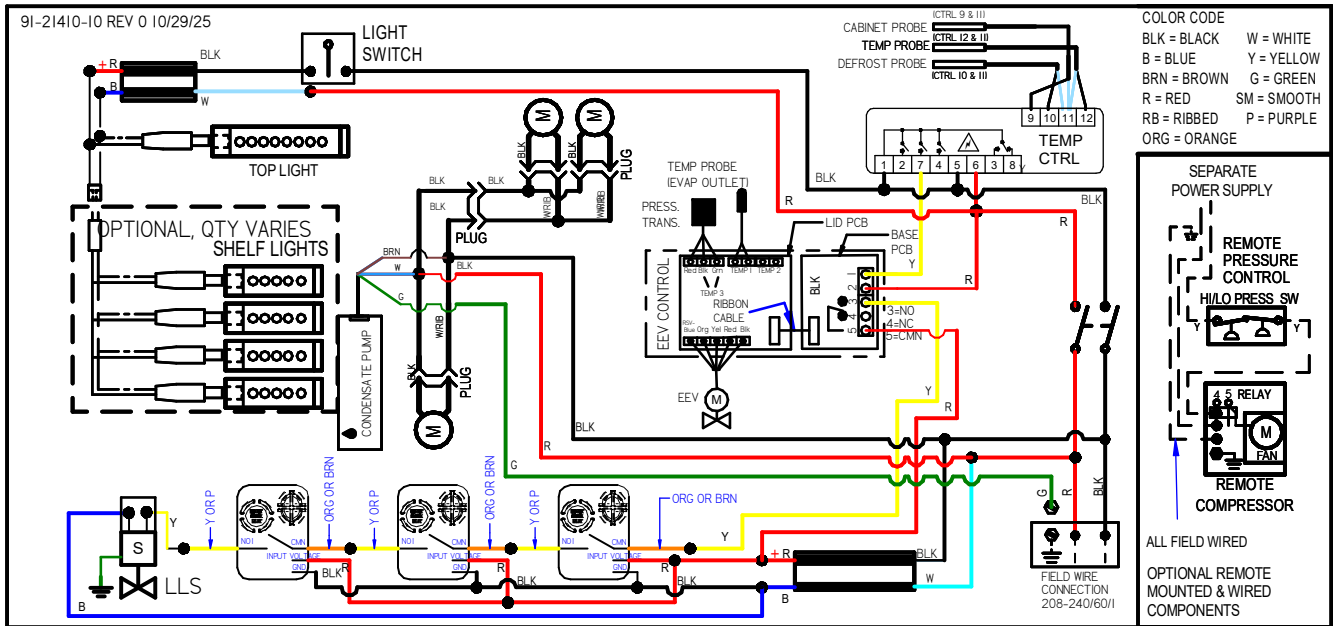

18.3 VNSS

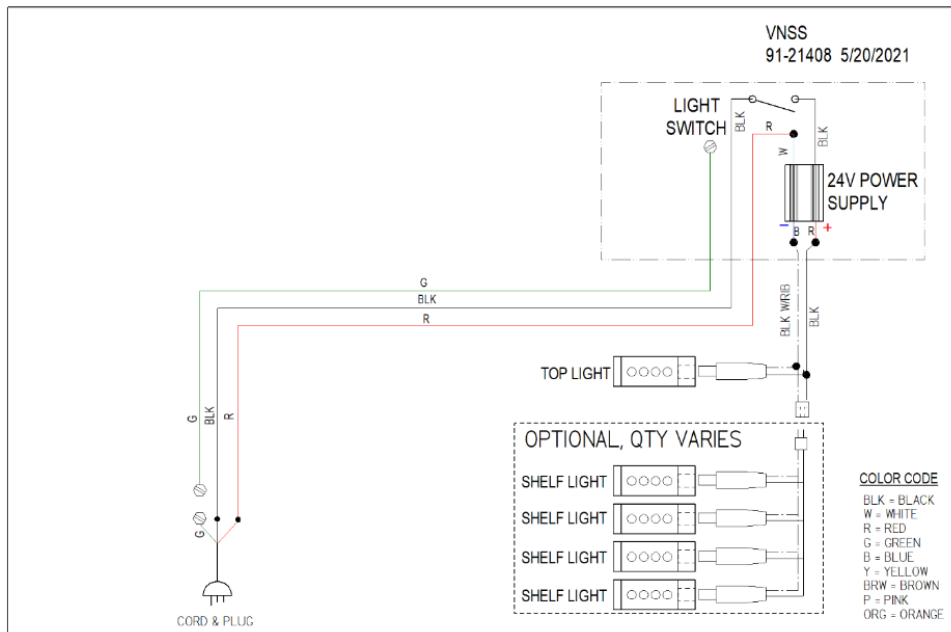



# (19) SERVICE PARTS

ELECTRICAL COMPONENTS	PART#	QTY	QTY	QTY	QTY	QTY	QTY	QTY	QTY	QTY	QTY	QTY
		2478	3683-MLK	3678	4878	6078	7278	2460	3660	4860	6060	7260
POWER CORD, 120V DRY (ALL VNSS UNITS)	43-20569	1	1	1	1	1	1	1	1	1	1	1
POWER CORD, 120V REFR NEMA 5-15	43-20569		1	1					1			
POWER CORD, 240V REFR NEMA 6-15	43-20949				1					1		
POWER CORD, 240V REFR NEMA 6-20	43-19457					1	1				1	1
TEMP. CONT. 120V (NON-REVERSING FAN)	32-21341-27		1	1					1			
TEMP. CONT. 120V REMOTE	32-21341-17R		1	1					1			
TEMP. CONT. 120V (REVERSING FAN)	32-21341-28		1	1					1			
TEMP. CONT. 240V(NON-REVERSING FAN)	32-21342-27				1	1	1			1	1	1
TEMP. CONT. 240V REMOTE (AFTER 7/1/24)	32-21342-17R				1	1	1			1	1	1
TEMP. CONT. 240V (REVERSING FAN)	32-21342-28				1	1	1			1	1	1
TEMP. CONT. 240V REMOTE (AFTER 11/1/25)	32-21342-33				1	1	1			1	1	1
TEMP. CONT. 120V REMOTE (AFTER 11/1/25)	32-21341-33		1	1					1			
TEMPERATURE PROBE 10'	32-19094		3	3	2	2	3		3	2	2	3
TEMPERATURE PROBE 20'	32-19866				1	1				1	1	
SWITCH,ROCKER POWER 22A	41-18186		1	1	1	1	1		1	1	1	1
SWITCH,ROCKER LIGHT22A	41-1066	1	1	1	1	1	1	1	1	1	1	1
HARNNESS,SHELF LIGHTS	43-21333	1	1	1	1	1	1		1	1	1	1
POWER SUPPLY 24V 100W (FOR SOLENOID VALVE) (REMOTE)	39-20555				1	1	1			1	1	1
POWER SUPPLY 24V 100W (FOR LIGHTS ALL)	39-20555	1	1	1	1	1	1		1	1	1	1
TOP LIGHT	42-20871-20C35	1						1				
	42-20871-30C35		1	1					1			
	42-20871-42C35				1					1		
	42-20871-54C35					1					1	
	42-20871-66C35						1					1
SHELF LIGHTS	42-20871-20C35	4						2				
	42-20871-25C35		4	4					2			
	42-20871-38C35				4					2		
	42-20871-54C35					4					2	
	42-20871-66C35						4					2
TAPE,LED LIGHT,DOUBLE SIDED (QTY PER LED)	90-20985	40in (.030 ROL)	49in (.038 ROL)	49in (.038 ROL)	70in (.054 ROL)	102in (.079 ROL)	126in (0.098 ROL)	49in (.038 ROL)	49in (.038 ROL)	70in (.054 ROL)	102in (.079 ROL)	126in (0.098 ROL)
		QTY	QTY	QTY	QTY	QTY	QTY	QTY	QTY	QTY	QTY	QTY
		2478	3683-MLK	3678	4878	6078	7278	2460	3660	4860	6060	7260
FAN MOTOR, BLADE, CORD, AND VENTURI VRSS	41-21237-14								2	2	3	3
FAN MOTOR, BLADE, CORD, AND VENTURI VRSS	41-21237-16		2	2	2	3	3					
FAN MOTOR, BLADE, CORD, AND VENTURI VRSL	41-21237-12								2		3	
FAN MOTOR, BLADE, CORD, AND VENTURI VRSL	41-21237-14		2	2		3				2		3
FAN MOTOR, BLADE, CORD, AND VENTURI VRSL	41-21237-16				2		3					
BASE FAN MOTOR, BLADE, CORD, AND VENTURI VRSS/VRSL	41-21237-20			1	1	1	1		1	1	1	1
FAN HARNNESS	43-21501		1	1	1	1	2		1	1	2	2
TXV (SELF CONTAINED)	32-21749				1					1		
TXV (SELF CONTAINED)	32-21750		1	1		2	2		1		2	2
EEV (REMOTE)	32-21228		1	1					1			
EEV (REMOTE)	32-21226				1	1	1			1	1	1
EEV PRESSURE TRANSDUCER (REMOTE)	32-21225		1	1	1	1	1		1	1	1	1
EEV CONTROL (REMOTE)	32-21233				1	1	1			1	1	1
SOLENOID VALVE (REMOTE) R454c	32-21915-6				1	1	1			1	1	1
COIL SOLENOID VALVE (REMOTE) R454c	32-21915-C24				1	1	1			1	1	1
CHECK VALVE (REMOTE) R454c	32-21916-5				1	1	1			1	1	1
SENSOR (REMOTE) R454c	32-21917				1	1	1			1	1	1
WIRE HARNNESS,SENSOR 4' LONG (REMOTE) R454c	43-21921-4				1	1	1			1	1	1
WIRE HARNNESS,SENSOR 8' LONG (REMOTE) R454c	43-21921-8				1	1	1			1	1	1
COIL,EVAPORATOR,36IN	33-21288-21		1	1					1			
COIL,EVAPORATOR,48IN	33-21288-22				1					1		
COIL,EVAPORATOR,60IN	33-21288-43					1					1	
COIL,EVAPORATOR,72IN	33-21288-44						1					1
COIL,EVAPORATOR,36IN REMOTE R449a only	33-21288-1		1	1					1			
COIL,EVAPORATOR,48IN REMOTE R449a & R454c	33-21288-2				1					1		
COIL,EVAPORATOR,60IN REMOTE R449a & R454c	33-21288-3					1					1	
COIL,EVAPORATOR,72IN REMOTE R449a & R454c	33-21288-4						1					1
FILTER DRIER (REPLACEMENT)	32-12391		1	1	1	1	1		1	1	1	1
COMPRESSOR	30-21754-COMP		1	1		2	2		1	1)120V OPT	2	2
COMPRESSOR	30-21766-COMP				1					1)240V STD		
CONDENSING UNIT	30-21754		1	1					1			
CONDENSING UNIT	30-21766				1					1		
CONDENSATE HEATER 600W 120V	40-19331		1	1					1			
CONDENSATE HEATER 600W 230V	40-19392				1	1	1			1	1	1

MISC COMPONENTS	PART#	QTY	QTY	QTY	QTY	QTY	QTY	QTY	QTY	QTY	QTY	QTY
		2478	3683-MLK	3678	4878	6078	7278	2460	3660	4860	6060	7260
LEG LEVELER,1/2-13 X 2.5	65-21273	4	4	4	4	4	4	4	4	4	4	4
AIR DIFFUSER, 36IN	W11823-1	---	1	1	---	---	---	---	1	---	---	---
AIR DIFFUSER, 48IN	W11823-2	---	---	---	1	---	---	---	---	1	---	---
AIR DIFFUSER, 60IN	W11823-3	---	---	---	---	2	---	---	---	---	2	---
AIR DIFFUSER, 72IN	W11823-4	---	---	---	---	---	2	---	---	---	---	2
PVC TUB FITTING FOR COPPER AND ELECTRICAL	84-21557	---	2	2	2	2	2	---	2	2	2	2
FITTING NUT	84-21558	---	2	2	2	2	2	---	2	2	2	2
FITTING GASKET	84-21559	---	2	2	2	2	2	---	2	2	2	2
SPRAY FOAM SEALANT	22-21574	---	1	1	1	1	1	---	1	1	1	1
DRAIN ASSY,TUBE,RAID REAR AIR IN/OUT	SA6228-1	---	---	---	---	2	---	---	---	---	2	---
DRAIN ASSY,TUBE,REMOTE W/PUMP 4' VRSS	SA6305-6	---	1	1	1	---	---	---	1	1	---	---
DRAIN ASSY,TUBE,REMOTE W/PUMP 5' VRSS	SA6305-7	---	---	---	---	1	---	---	---	---	1	---
DRAIN ASSY,TUBE,REMOTE W/PUMP 6' VRSS	SA6305-8	---	---	---	---	---	1	---	---	---	---	1
THERMOPLASTIC DRAIN	84-70225	---	1	1	1	2	2	---	1	1	2	2
DRAIN WASHER	M-6229	---	1	1	1	2	2	---	1	1	2	2
AIR DEFLECTOR VRSS 78" TALL	51-21305-1	---	1	1	---	---	---	---	---	---	---	---
	51-21305-2	---	---	---	1	---	---	---	---	---	---	---
	51-21305-3	---	---	---	---	1	---	---	---	---	---	---
	51-21305-4	---	---	---	---	---	1	---	---	---	---	---
AIR DEFLECTOR VRSS 60" & VRSL ALL	51-21305-11	---	1	1	---	---	---	---	1	---	---	---
	51-21305-12	---	---	---	1	---	---	---	---	1	---	---
	51-21305-13	---	---	---	---	1	---	---	---	---	1	---
	51-21305-14	---	---	---	---	---	1	---	---	---	---	1
AIR DEFLECTOR FOR CASES W/ROLL COVER VRSS	51-21305-5	---	1	1	---	---	---	---	---	---	---	---
	51-21305-6	---	---	---	1	---	---	---	---	---	---	---
	51-21305-7	---	---	---	---	1	---	---	---	---	---	---
	51-21305-8	---	---	---	---	---	1	---	---	---	---	---
	51-21305-15	---	---	---	---	---	---	---	1	---	---	---
	51-21305-16	---	---	---	---	---	---	---	---	1	---	---
	51-21305-17	---	---	---	---	---	---	---	---	---	1	---
	51-21305-18	---	---	---	---	---	---	---	---	---	---	1
AIR DEFLECTOR FOR CASES W/ROLL COVER VRSL	51-21305-29	---	1	1	---	---	---	---	1	---	---	---
	51-21305-30	---	---	---	1	---	---	---	---	1	---	---
	51-21305-31	---	---	---	---	1	---	---	---	---	1	---
	51-21305-32	---	---	---	---	---	1	---	---	---	---	1
AIR DEFLECTOR SLIDE-IN 60" TALL CASES ONLY VRSS	51-21305-21	---	---	---	---	---	---	---	1	---	---	---
	51-21305-22	---	---	---	---	---	---	---	---	1	---	---
	51-21305-23	---	---	---	---	---	---	---	---	---	1	---
	51-21305-24	---	---	---	---	---	---	---	---	---	---	1
AIR DEFLECTOR SLIDE-IN W/ROLL COVER 60" VRSS	51-21305-25	---	---	---	---	---	---	---	1	---	---	---
	51-21305-26	---	---	---	---	---	---	---	---	1	---	---
	51-21305-27	---	---	---	---	---	---	---	---	---	1	---
	51-21305-28	---	---	---	---	---	---	---	---	---	---	1
NIGHT CURTAIN	65-19300	---	1	1	---	---	2	---	1	---	---	2
	65-21374	---	---	---	1	---	---	---	---	1	---	---
	65-19458	---	---	---	---	2	---	---	---	---	2	---
SECURITY COVER (OPTIONAL) KIT VRSS	800-9611-BK	---	---	---	---	---	---	---	1	---	---	---
	801-9611-BK	---	1	1	---	---	---	---	---	---	---	---
	802-9611-BK	---	---	---	---	---	---	---	---	1	---	---
	803-9611-BK	---	---	---	1	---	---	---	---	---	---	---
	804-9611-BK	---	---	---	---	---	---	---	---	---	1	---
	805-9611-BK	---	---	---	---	1	---	---	---	---	---	---
	806-9611-BK	---	---	---	---	---	---	---	---	---	---	1
	807-9611-BK	---	---	---	---	---	1	---	---	---	---	---
SECURITY COVER (OPTIONAL) KIT VRSL	810-9611-EXTB	---	---	---	---	---	---	---	1	---	---	---
	811-9611-EXTB	---	1	1	---	---	---	---	---	---	---	---
	812-9611-EXTB	---	---	---	---	---	---	---	---	1	---	---
	813-9611-EXTB	---	---	---	1	---	---	---	---	---	---	---
	814-9611-EXTB	---	---	---	---	---	---	---	---	---	1	---
	815-9611-EXTB	---	---	---	---	1	---	---	---	---	---	---
	816-9611-EXTB	---	---	---	---	---	---	---	---	---	---	1
	817-9611-EXTB	---	---	---	---	---	1	---	---	---	---	---

MISC COMPONENTS CONTINUED	PART#	QTY	QTY	QTY	QTY	QTY	QTY	QTY	QTY	QTY	QTY	QTY
		2478	3683-MLK	3678	4878	6078	7278	2460	3660	4860	6060	7260
<b>BASE FRONT GRILLE ASSEMBLY VISION FIFO VRSS</b>	SA6266-11B	---	1	1	---	---	---	---	1	---	---	---
	SA6266-12B	---	---	---	1	---	---	---	---	1	---	---
	SA6266-13B	---	---	---	---	1	---	---	---	---	1	---
	SA6266-14B	---	---	---	---	---	1	---	---	---	---	1
<b>BASE FRONT GRILLE ASSEMBLY VISION FIFO VRSL</b>	SA6266-1B	---	1	1	---	---	---	---	1	---	---	---
	SA6266-2B	---	---	---	1	---	---	---	---	1	---	---
	SA6266-3B	---	---	---	---	1	---	---	---	---	1	---
	SA6266-4B	---	---	---	---	---	1	---	---	---	---	1
<b>BASE FRONT GRILLE ASSEMBLY VISION FIRO VRSS</b>	SA6018-11B	---	1	1	---	---	---	---	1	---	---	---
	SA6018-12B	---	---	---	1	---	---	---	---	1	---	---
	SA6018-13B	---	---	---	---	1	---	---	---	---	1	---
	SA6018-14B	---	---	---	---	---	1	---	---	---	---	1
<b>BASE FRONT GRILLE ASSEMBLY VISION FIRO VRSL</b>	SA6183-1B	---	1	1	---	---	---	---	1	---	---	---
	SA6183-2B	---	---	---	1	---	---	---	---	1	---	---
	SA6183-3B	---	---	---	---	1	---	---	---	---	1	---
	SA6183-4B	---	---	---	---	---	1	---	---	---	---	1
<b>BASE FRONT PANEL VRSL-MLK</b>	M21963-1B	---	1	---	---	---	---	---	---	---	---	---
<b>BASE FRONT PANEL DRY &amp; REMOTE VRSS, VNSS</b>	SA6294-B	1	---	---	---	---	---	1	---	---	---	---
	SA6294-1B	---	1	1	---	---	---	---	1	---	---	---
	SA6294-2B	---	---	---	1	---	---	---	---	1	---	---
	SA6294-3B	---	---	---	---	1	---	---	---	---	1	---
	SA6294-4B	---	---	---	---	---	1	---	---	---	---	1
<b>BASE FRONT PANEL RIRO &amp; SLIDE-IN VRSS</b>	SA6294-1B	---	---	---	---	---	---	1	1	---	---	---
	SA6294-2B	---	---	---	---	---	---	---	---	1	---	---
	SA6294-3B	---	---	---	---	---	---	---	---	---	1	---
	SA6294-4B	---	---	---	---	---	---	---	---	---	---	1
<b>BASE FRONT PANEL RIRO &amp; SLIDE-IN VRSL</b>	SA6293-1B	---	---	---	---	---	---	1	1	---	---	---
	SA6293-2B	---	---	---	---	---	---	---	---	1	---	---
	SA6293-3B	---	---	---	---	---	---	---	---	---	1	---
	SA6293-4B	---	---	---	---	---	---	---	---	---	---	1
<b>DECAL, CAUTION ELECTRICAL SHOCK</b>	91-12340	1	1	1	1	1	1	1	1	1	1	1
<b>LOGO, FEDERAL</b>	91-72523	1	1	1	1	1	1	1	1	1	1	1

END PANELS SLIDE-IN		
	LEFT	RIGHT
<b>END GLASS PANELS SQUARE CLEAR</b>		
BLACK	50-21605-2B	50-21605-2B
<b>END GLASS PANELS SQUARE REFLECTIVE</b>		
	50-21605-12LB	50-21605-12RB
<b>END GLASS PANELS CURVED CLEAR</b>		
BLACK	50-21619-2B	50-21619-2B
<b>END GLASS PANELS CURVED REFLECTIVE</b>		
	50-21619-12LB	50-21619-12RB
<b>END PANELS FOR SOLID END STRAIGHT PROFILE LAMINATED, 60IN HEIGHT</b>		
BLACK	68-21623-23L	68-21623-23R
WHITE	68-21623-26L	68-21623-26R
<b>END PANELS FOR SOLID END CURVED PROFILE LAMINATED, 60IN HEIGHT</b>		
BLACK	68-21622-23L	68-21622-23R
WHITE	68-21622-26L	68-21622-26R

GLASS END PANELS VISION		
	LEFT	RIGHT
<b>END GLASS PANELS SQUARE CLEAR 60" TALL</b>		
BLACK	50-21330-2B	50-21330-2B
<b>END GLASS PANELS SQUARE REFLECTIVE 60" TALL</b>		
BLACK	50-21330-12LB	50-21330-12RB
<b>END GLASS PANELS SQUARE CLEAR 78" TALL</b>		
BLACK	50-21330-1B	50-21330-1B
<b>END GLASS PANELS SQUARE REFLECTIVE 78" TALL</b>		
BLACK	50-21330-11LB	50-21330-11RB
<b>END GLASS PANELS CURVED CLEAR 60" TALL</b>		
BLACK	50-21299-2B	50-21299-2B
<b>END GLASS PANELS CURVED REFLECTIVE 60" TALL</b>		
BLACK	50-21299-12LB	50-21299-12RB
<b>END GLASS PANELS CURVED CLEAR 78" TALL</b>		
BLACK	50-21299-1B	50-21299-1B
<b>END GLASS PANELS CURVED REFLECTIVE 78" TALL</b>		
BLACK	50-21619-11LB	50-21619-11RB

VRSS METAL SHELVING			
<b>SHELF PARTS FOR 78IN, TOP 2 15IN DEEP SHELVES FOR 24IN LONG UNITS</b>			
COLOR	BRACKET (NEED TWO)	SUPPORT	SHELF
BLACK	67-21387-1B	M21488-B	M21487-10B
WHITE	67-21387-1W	M21488-W	M21487-10W
STAINLESS	67-21387-1S	M21488-S	M21487-10S
<b>15IN DEEP SHELVES FOR TOP TWO SHELVES OF 78IN TALL, 36IN LONG</b>			
COLOR	BRACKET (NEED TWO)	SUPPORT	SHELF
BLACK	67-21387-1B	M21488-1B	M21487-11B
WHITE	67-21387-1W	M21488-1W	M21487-11W
STAINLESS	67-21387-1S	M21488-1S	M21487-11S
<b>15IN DEEP SHELVES FOR TOP TWO SHELVES OF 78IN TALL, 48IN LONG</b>			
COLOR	BRACKET (NEED TWO)	SUPPORT	SHELF
BLACK	67-21387-1B	M21488-2B	M21487-12B
WHITE	67-21387-1W	M21488-2W	M21487-12W
STAINLESS	67-21387-1S	M21488-2S	M21487-12S
<b>15IN DEEP SHELVES FOR TOP TWO SHELVES OF 78IN TALL, 60IN LONG</b>			
COLOR	BRACKET (NEED TWO)	SUPPORT	SHELF
BLACK	67-21387-1B	M21488-3B	M21487-13B
WHITE	67-21387-1W	M21488-3W	M21487-13W
STAINLESS	67-21387-1S	M21488-3S	M21487-13S
<b>15IN DEEP SHELVES FOR TOP TWO SHELVES OF 78IN TALL, 72IN LONG</b>			
COLOR	BRACKET (NEED TWO)	SUPPORT	SHELF
BLACK	67-21387-1B	M21488-4B	M21487-14B
WHITE	67-21387-1W	M21488-4W	M21487-14W
STAINLESS	67-21387-1S	M21488-4S	M21487-14S
<b>17IN DEEP SHELVES FOR BOTTOM TWO SHELVES OF 78IN TALL OR ANY 60IN TALL, 24IN LONG</b>			
COLOR	BRACKET (NEED TWO)	SUPPORT	SHELF
BLACK	67-21387-B	M21488-B	M21487-B
WHITE	67-21387-W	M21488-W	M21487-W
STAINLESS	67-21387-S	M21488-S	M21487-S
<b>17IN DEEP SHELVES FOR BOTTOM TWO SHELVES OF 78IN TALL OR ANY 60IN TALL, 36IN LONG</b>			
COLOR	BRACKET (NEED TWO)	SUPPORT	SHELF
BLACK	67-21387-B	M21488-1B	M21487-1B
WHITE	67-21387-W	M21488-1W	M21487-1W
STAINLESS	67-21387-S	M21488-1S	M21487-1S
<b>17IN DEEP SHELVES FOR BOTTOM TWO SHELVES OF 78IN TALL OR ANY 60IN TALL, 48IN LONG</b>			
COLOR	BRACKET (NEED TWO)	SUPPORT	SHELF
BLACK	67-21387-B	M21488-2B	M21487-2B
WHITE	67-21387-W	M21488-2W	M21487-2W
STAINLESS	67-21387-S	M21488-2S	M21487-2S
<b>17IN DEEP SHELVES FOR BOTTOM TWO SHELVES OF 78IN TALL OR ANY 60IN TALL, 60IN LONG</b>			
COLOR	BRACKET (NEED TWO)	SUPPORT	SHELF
BLACK	67-21387-B	M21488-3B	M21487-3B
WHITE	67-21387-W	M21488-3W	M21487-3W
STAINLESS	67-21387-S	M21488-3S	M21487-3S
<b>17IN DEEP SHELVES FOR BOTTOM TWO SHELVES OF 78IN TALL OR ANY 60IN TALL, 72IN LONG</b>			
COLOR	BRACKET (NEED TWO)	SUPPORT	SHELF
BLACK	67-21387-B	M21488-4B	M21487-4B
WHITE	67-21387-W	M21488-4W	M21487-4W
STAINLESS	67-21387-S	M21488-4S	M21487-4S
<b>18.5 IN DEEP TWO SHELVES FOR 78" TALL SALAD CASE ONLY, 72IN LONG</b>			
COLOR	BRACKET (NEED TWO)	SUPPORT	SHELF
STAINLESS	67-21944	M21488-4S	M22402-4S

VRSS GLASS SHELVING			
15IN DEEP SHELVES FOR TOP TWO SHELVES OF 78IN TALL, 24IN LONG			
COLOR	BRACKET (NEED TWO)	SUPPORT (NEED 1 EA.)	SHELF (1)
BLACK	67-21387-1B	M21488-B FRONT	52-21711
		M21885-B BACK	
WHITE	67-21387-1W	M21488-W FRONT	
		M21885-W BACK	
STAINLESS	67-21387-1S	M21488-S FRONT	
		M21885-S BACK	
15IN DEEP SHELVES FOR TOP TWO SHELVES OF 78IN TALL, 36IN LONG			
COLOR	BRACKET (NEED TWO)	SUPPORT (NEED 1 EA.)	SHELF (1)
BLACK	67-21387-1B	M21488-1B FRONT	52-21711-1
		M21885-1B BACK	
WHITE	67-21387-1W	M21488-1W FRONT	
		M21885-1W BACK	
STAINLESS	67-21387-1S	M21488-1S FRONT	
		M21885-1S BACK	
15IN DEEP SHELVES FOR TOP TWO SHELVES OF 78IN TALL, 48IN LONG			
COLOR	BRACKET (NEED TWO)	SUPPORT (NEED 1 EA.)	SHELF (1)
BLACK	67-21387-1B	M21488-2B FRONT	52-21711-2
		M21885-2B BACK	
WHITE	67-21387-1W	M21488-2W FRONT	
		M21885-2W BACK	
STAINLESS	67-21387-1S	M21488-2S FRONT	
		M21885-2S BACK	
15IN DEEP SHELVES FOR TOP TWO SHELVES OF 78IN TALL, 60IN LONG			
COLOR	BRACKET (NEED TWO)	SUPPORT (NEED 1 EA.)	SHELF (2)
BLACK	67-21387-1B	M21488-3B FRONT	52-21711-3
		M21885-3B BACK	
WHITE	67-21387-1W	M21488-3W FRONT	
		M21885-3W BACK	
STAINLESS	67-21387-1S	M21488-3S FRONT	
		M21885-3S BACK	
15IN DEEP SHELVES FOR TOP TWO SHELVES OF 78IN TALL, 72IN LONG			
COLOR	BRACKET (NEED TWO)	SUPPORT (NEED 1 EA.)	SHELF (2)
BLACK	67-21387-1B	M21488-4B FRONT	52-21711-4
		M21885-4B BACK	
WHITE	67-21387-1W	M21488-4W FRONT	
		M21885-4W BACK	
STAINLESS	67-21387-1S	M21488-4S FRONT	
		M21885-4S BACK	
17IN DEEP SHELVES FOR BOTTOM TWO SHELVES OF 78IN TALL OR ANY 60IN TALL, 24IN LONG			
COLOR	BRACKET (NEED TWO)	SUPPORT (NEED 1 EA.)	SHELF (1)
BLACK	67-21387-B	M21488-B FRONT	52-21711-10
		M21885-B BACK	
WHITE	67-21387-W	M21488-W FRONT	
		M21885-W BACK	
STAINLESS	67-21387-S	M21488-S FRONT	
		M21885-S BACK	
17IN DEEP SHELVES FOR BOTTOM TWO SHELVES OF 78IN TALL OR ANY 60IN TALL, 36IN LONG			
COLOR	BRACKET (NEED TWO)	SUPPORT (NEED 1 EA.)	SHELF (1)
BLACK	67-21387-B	M21488-1B FRONT	52-21711-11
		M21885-1B BACK	
WHITE	67-21387-W	M21488-1W FRONT	
		M21885-1W BACK	
STAINLESS	67-21387-S	M21488-1S FRONT	
		M21885-1S BACK	
17IN DEEP SHELVES FOR BOTTOM TWO SHELVES OF 78IN TALL OR ANY 60IN TALL, 48IN LONG			
COLOR	BRACKET (NEED TWO)	SUPPORT (NEED 1 EA.)	SHELF (1)
BLACK	67-21387-B	M21488-2B FRONT	52-21711-12
		M21885-2B BACK	
WHITE	67-21387-W	M21488-2W FRONT	
		M21885-2W BACK	
STAINLESS	67-21387-S	M21488-2S FRONT	
		M21885-2S BACK	
17IN DEEP SHELVES FOR BOTTOM TWO SHELVES OF 78IN TALL OR ANY 60IN TALL, 60IN LONG			
COLOR	BRACKET (NEED TWO)	SUPPORT (NEED 1 EA.)	SHELF (2)
BLACK	67-21387-B	M21488-3B FRONT	52-21711-13
		M21885-3B BACK	
WHITE	67-21387-W	M21488-3W FRONT	
		M21885-3W BACK	
STAINLESS	67-21387-S	M21488-3S FRONT	
		M21885-3S BACK	
17IN DEEP SHELVES FOR BOTTOM TWO SHELVES OF 78IN TALL OR ANY 60IN TALL, 72IN LONG			
COLOR	BRACKET (NEED TWO)	SUPPORT (NEED 1 EA.)	SHELF (2)
BLACK	67-21387-B	M21488-4B FRONT	52-21711-14
		M21885-4B BACK	
WHITE	67-21387-W	M21488-4W FRONT	
		M21885-4W BACK	
STAINLESS	67-21387-S	M21488-4S FRONT	
		M21885-4S BACK	

## VRSL METAL SHELVING

### SHELF PARTS FOR 12.5"IN DEEP SHELVES FOR 36IN LONG UNITS

COLOR	BRACKET (NEED TWO)	SUPPORT	SHELF
BLACK	67-21723-B	M21488-1B	M21487-16B
WHITE	67-21723-W	M21488-1W	M21487-16W
STAINLESS	67-21723-S	M21488-1S	M21487-16S

### SHELF PARTS FOR 12.5"IN DEEP SHELVES FOR 48IN LONG UNITS

COLOR	BRACKET (NEED TWO)	SUPPORT	SHELF
BLACK	67-21387-1B	M21488-2B	M21487-17B
WHITE	67-21387-1W	M21488-2W	M21487-17W
STAINLESS	67-21387-1S	M21488-2S	M21487-17S

### SHELF PARTS FOR 12.5"IN DEEP SHELVES FOR 60IN LONG UNITS

COLOR	BRACKET (NEED TWO)	SUPPORT	SHELF
BLACK	67-21387-1B	M21488-3B	M21487-18B
WHITE	67-21387-1W	M21488-3W	M21487-18W
STAINLESS	67-21387-1S	M21488-3S	M21487-18S

### SHELF PARTS FOR 12.5"IN DEEP SHELVES FOR 72IN LONG UNITS

COLOR	BRACKET (NEED TWO)	SUPPORT	SHELF
BLACK	67-21387-1B	M21488-4B	M21987-19B
WHITE	67-21387-1W	M21488-4W	M21987-19W
STAINLESS	67-21387-1S	M21488-4S	M21987-19S

VRSL GLASS SHELVING			
SHELF PARTS FOR 12.5 "IN DEEP SHELVES FOR 36IN LONG UNITS			
COLOR	BRACKET (NEED TWO)	SUPPORT (NEED 1 EA.)	SHELF
BLACK	67-21723-B	M21488-1B FRONT	52-21711-21
		M21885-1B BACK	
WHITE	67-21723-W	M21488-1W FRONT	
		M21885-1W BACK	
STAINLESS	67-21723-S	M21488-1S FRONT	
		M21885-1S BACK	
SHELF PARTS FOR 12.5 "IN DEEP SHELVES FOR 48IN LONG UNITS			
COLOR	BRACKET (NEED TWO)	SUPPORT (NEED 1 EA.)	SHELF
BLACK	67-21387-1B	M21488-2B FRONT	52-21711-22
		M21885-2B BACK	
WHITE	67-21387-1W	M21488-2W FRONT	
		M21885-2W BACK	
STAINLESS	67-21387-1S	M21488-2S FRONT	
		M21885-2S BACK	
SHELF PARTS FOR 12.5"IN DEEP SHELVES FOR 60IN LONG UNITS			
COLOR	BRACKET (NEED TWO)	SUPPORT (NEED 1 EA.)	SHELF NEED (2)
BLACK	67-21387-1B	M21488-3B FRONT	52-21711-23
		M21885-3B BACK	
WHITE	67-21387-1W	M21488-3W FRONT	
		M21885-3W BACK	
STAINLESS	67-21387-1S	M21488-3S FRONT	
		M21885-3S BACK	
SHELF PARTS FOR 12.5"IN DEEP SHELVES FOR 72IN LONG UNITS			
COLOR	BRACKET (NEED TWO)	SUPPORT (NEED 1 EA,)	SHELF NEED (2)
BLACK	67-21387-1B	M21488-4B FRONT	52-21711-24
		M21885-4B BACK	
WHITE	67-21387-1W	M21488-4W FRONT	
		M21885-4W BACK	
STAINLESS	67-21387-1S	M21488-4S FRONT	
		M21885-4S BACK	

LEGS AND CASTERS		
Description	PART#	QTY/CASE
<b>LEG LEVELER ASSEMBLY</b>	<b>SA4368-1</b>	<b>4</b>
LEG LEVELER	65-21273	4
HOUSING	SA4295	4
<b>6" LEG ASSEMBLY</b>	<b>SA4368-2</b>	<b>4</b>
6" LEG	65-12886	4
SCREW, 1/4-20	75-10948	16
HOUSING	SA4295	4
<b>4" CASTER ASSEMBLY</b>	<b>SA4368-3</b>	<b>4</b>
4" CASTER	65-10675	4
SCREW, 1/4-20	75-10948	16
HOUSING	SA4295	4
<b>2.5" CASTER ASSEMBLY</b>	<b>SA4368-20</b>	<b>4</b>
2.5" CASTER	65-15185	4
SCREW, 1/4-20	75-10948	16
HOUSING	SA4295	4
<b>RECESSED CASTER ASSEMBLY</b>	<b>SA4368-4</b>	<b>4</b>
2.5" CASTER	65-17352	4
SCREW, 1/4-20	75-10948	16
HOUSING	M15895-2	4
<b>6" SEISMIC LEG ASSEMBLY</b>	<b>SA4368-13</b>	<b>4</b>
6" SEISMIC LEG	65-19069	4
SCREW, 1/4-20	75-10948	16
HOUSING	SA4295	4
<b>SLIDE -IN ADJUSTABLE CASTER ASSEMBLIES</b>		<b>4</b>
ADJUSTABLE CASTERS SLIDE-IN	65-21657	4
SCREW, 1/4-20	75-10948	64
INNER SLIDE HOUSING	M21799	4
OUTER SLIDE HOUSING	M21798	4
BRACE SLIDE HOUSING	M21814	2

<b>Kits</b>	
<b>LED Shelf Lights</b>	<b>Kit#</b>
VRSS/VNSS2460	828-9200-LEDK
VRSS/VNSS3660	800-9200-LEDK
VRSS/VNSS2478	829-9200-LEDK
VRSS/VNSS3678/VRSL-MLK	801-9200-LEDK
VRSS/VNSS4860	802-9200-LEDK
VRSS/VNSS4878	803-9200-LEDK
VRSS/VNSS6060	804-9200-LEDK
VRSS/VNSS6078	805-9200-LEDK
VRSS/VNSS7260	806-9200-LEDK
VRSS/VNSS7278	807-9200-LEDK

<b>High Output Condensate Pan, <b>Single</b> Drain Units</b>	<b>Kit#</b>
VRSS36 ONLY	800-9121-PANK
VRSS48 ONLY	802-9121-PANK
<b>High Output Condensate Pan, <b>Dual</b> Drain Units</b>	
VRSS60 ONLY	804-9122-PANK
VRSS72 ONLY	806-9122-PANK



