

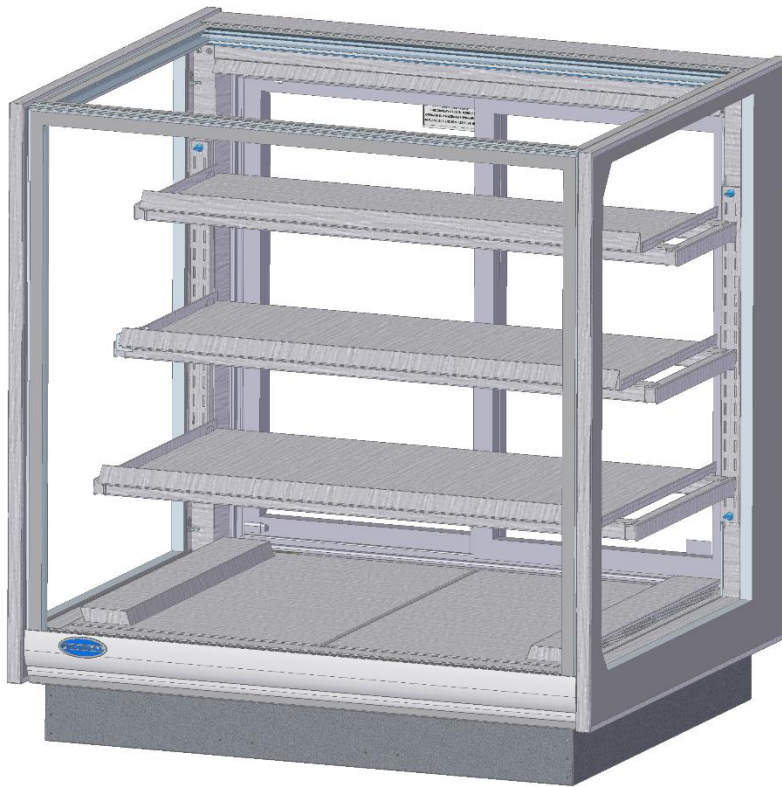

The Signature of Quality®

INSTALLATION & OPERATIONS INSTRUCTIONS

ITH: Heated Models





CONTENTS

(1)	Introduction	3
1.1	Serial Number	3
(2)	Warning Labels & Safety Instructions.....	4
(3)	Prior To Unpacking Equipment!	5
(4)	General Electrical & Grounding	6
4.1	Cord Connected	6
(5)	Installation Instructions	7
5.1	Locating The Display Case	7
5.2	Removing Case From Shipping Skid	7
5.3	Single Case Installation (Stand alone units)	7
5.4	Prior to Initial Use	8
(6)	Compartment Panel Removal.....	9
	Top Cover.....	10
(7)	End Panel Installation	11
(8)	Shelving Installation and Removal.....	12
8.1	Shelf Brackets and Supports.....	12
(9)	Front And Rear Doors Removal	16
(10)	Control Operation	18
10.1	Air Temperature Control.....	18
10.2	Humidity Control And Pan Operation (When Equipped).....	20
10.3	Typical Humidity Conditions.....	21
(11)	Food Packaging Recommendations	22
(12)	Cleaning Instructions	23
12.1	Daily Cleaning	23
12.2	Weekly Cleaning	23
12.3	Cleaning The Optional Humidity Pan	24
(13)	Service.....	26
(14)	Sale & Disposal	27
14.1	Owner Responsibility	27
(15)	Troubleshooting.....	28
(16)	Service Parts	30

(1) Introduction

Thank you for purchasing a Federal Industries display case. This manual contains important instructions for installing and servicing your new display case. A repair parts list and wiring diagram are also included in the manual. Read all of these documents carefully before installing or servicing your case.

	<p>NOTICE</p> <p>Read this manual before installing your case. Keep this manual and refer to it before doing any service on the equipment. Failure to do so could result in personal injury or damage to the case.</p>
	<p>NOTICE</p> <p>Installation and service of the electrical components in the case must be performed by a licensed electrician.</p> <p>The portions of this manual covering components contain technical instructions intended only for persons qualified to perform electrical work.</p>
	<p>DANGER</p> <p>Improper or faulty hookup of electrical components in the case can result in severe injury or death.</p> <p>All electrical wiring hookups must be done in accordance with all applicable local, regional, or national standards.</p>

1.1 SERIAL NUMBER

Record the model and serial numbers of the case for easy reference. Always refer to both model and serial numbers in your correspondence with Federal regarding the case.

Case Model _____ Serial Number _____

This manual cannot cover every installation, use, or service situation. If you need additional information, call or write us:

WARRANTY/TECHNICAL SERVICE DEPARTMENT

Parts Town

1200 Greenbriar Dr.

Addison, IL 60101

Toll Free: (833) 238-8168

Email: techservice@partstown.com



(2) WARNING LABELS & SAFETY INSTRUCTIONS



This is the safety-alert symbol. When you see this symbol on your case or in the manual, be alert to the potential for personal injury or damage to your equipment.

Be sure you understand all safety messages and always follow recommended precautions and safe operating procedures.



NOTICE TO EMPLOYERS:

You must make sure that everyone who installs, uses, or services your case is thoroughly familiar with all safety information and procedures.

Important safety information is presented in this section and throughout the manual. The following signal words are used in the warning and safety messages:

DANGER:	Severe injury or death will occur if you ignore the message.
WARNING:	Severe injury or death can occur if you ignore the message.
CAUTION:	Minor injury or damage to your case can occur if you ignore the message.
NOTICE:	This is important installation, operation, or service information. If you ignore the message, you may damage your case.

The warning and safety labels shown throughout this manual are placed on your Federal Industries case at the factory. Follow all warning label instructions. If any warning or safety labels become lost or damaged, call our customer service department at (800) 356-4206 for replacements.

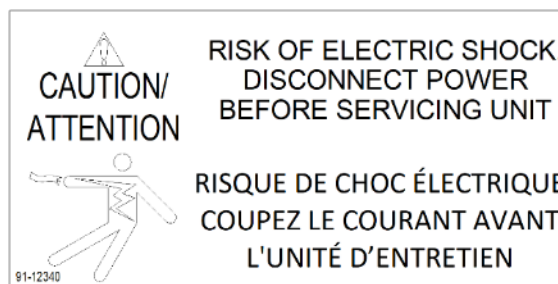

Located at front of unit and on shelves

(3) PRIOR TO UNPACKING EQUIPMENT!

Inspect for shipping damage.

You are responsible for filing all freight claims with the delivering truck line. Inspect all cartons and crates for damage as soon as they arrive. If damage is noted to shipping crates, cartons, or if a shortage is found, note this on the bill of lading (all copies) prior to signing.

If damage is discovered when the case is uncrated, immediately call the delivering truck line and follow-up the call with a written report indicating concealed damage to your shipment. Ask for an immediate inspection of your concealed damaged item. Crating material must be retained to show the inspector from the truck line.

(4) GENERAL ELECTRICAL & GROUNDING



WARNING:

Improper or faulty hookup of electrical components in the display case can result in severe injury or death.

4.1 CORD CONNECTED

For models that are supplied with a power cord, the cord is properly sized to the amperage requirements of the case. See the rating plate for specific unit requirements.



CAUTION

Risk of Electric Shock. If the cord or plug becomes damaged, replace only with a cord and plug of the same type.

(5) INSTALLATION INSTRUCTIONS

5.1 LOCATING THE DISPLAY CASE

The case must be located where it is not subjected to the direct rays of the sun, heating ducts, grills, radiator, or ceiling fans, nor should it be located near open doors or main door entrances. Also, avoid locations where there are excessive air movement or air disturbances.

There are no special clearance requirements for this unit.

5.2 REMOVING CASE FROM SHIPPING SKID

Be sure to leave shelf packaging material intact for this step.

First remove the base front and rear panels

Two or more people should be involved in moving the unit from the pallet onto the ground.

Remove the (4) 1/4" screws that secure the case to the skid. These screws are located in the front and rear corners of the base rails inside of the front and rear base access panels/grills.

Once all the bolts are removed, slide the unit off the back of the shipping pallet, and tilt it so the rear corner touches the ground. Then have someone move pallet out from under the case and gently tilt the case forward until it touches the floor.

5.2.1 Removing Packaging Material

Remove bubble wrap and packing material for all shelves and panel, brackets, etc. If it is necessary to remove tape residue from plastic materials, use cleaning compounds recommended in the cleaning section of this manual.

5.2.2 Lifting and Moving the Case



Caution:

Do not push or pull against the top end glass, or door frames and do not pull on end panels when removing the case from the skid or moving the case. Case damage or glass breakage will result.

5.3 SINGLE CASE INSTALLATION (STAND ALONE UNITS)

NOTE: If necessary, use a wood or plastic shim under each leg leveler to avoid scratching the tile floor.

5.3.1 Sealing Unit to The Floor

After the unit is positioned and the leg levelers are turned out, the unit needs to be sealed to the floor for NSF approved installation. This is not required for models with casters or legs.

5.4 PRIOR TO INITIAL USE

Unit must be cleaned as indicated in the “WEEKLY CLEANING” section of this manual before initial use.

(6) COMPARTMENT PANEL REMOVAL

Floor Base Models Back Panel

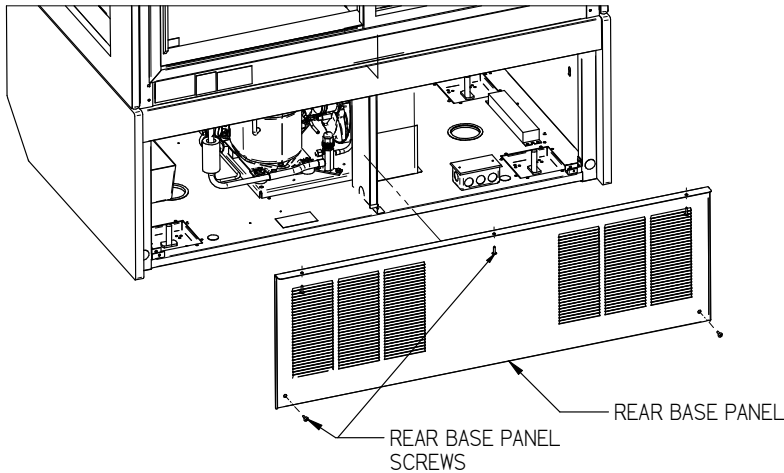

1. Remove screws located in each lower corner of panel.
2. Remove screws located on top of panel under the base cross member.
3. Pull top of panel outward until lip on bottom of panel clears bottom of base and remove from case.

Front Panel

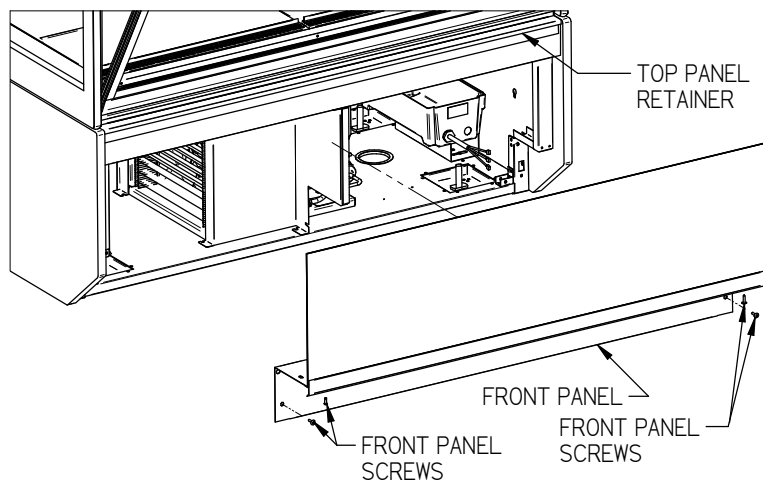

1. Disconnect power to Display Case.
2. Remove (2) front panel phillip head screws from each lower corner of front panel (1) is located on front of panel and the other under the recess behind trim strip. Do not remove the screws holding trip strip to front panel.
3. Slide the front panel down until it slides out of the top panel retainer lip at the top of the panel.
4. Install panel in reverse order.

TOP COVER



DANGER: Electric shock hazard. Do not operate unit with panels removed.

Light Power Supply is located on top of case under the top cover.

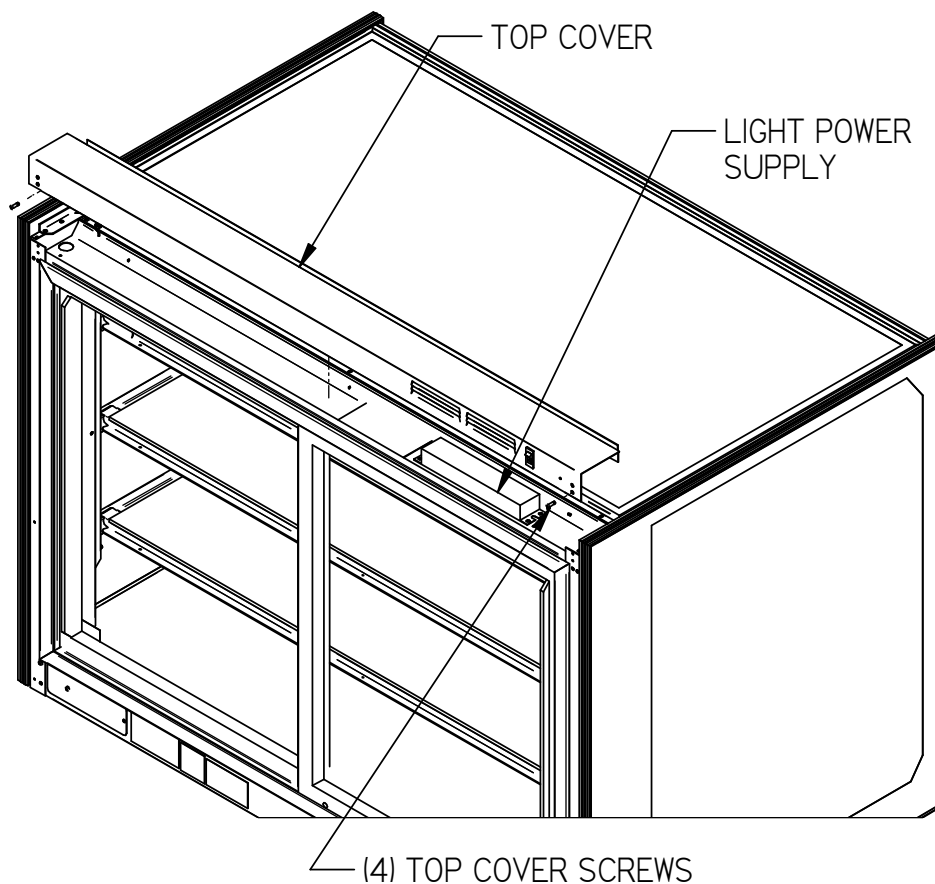

1. Disconnect power to Display Case.
2. Remove the (4) 8-32 top cover screws from top cover.
3. Slide the cover back from under the top glass trim.
Note: there is a ground wire connected from case to the Top Cover. To prevent electrical shock **Do NOT remove this wire.**

(7) END PANEL INSTALLATION

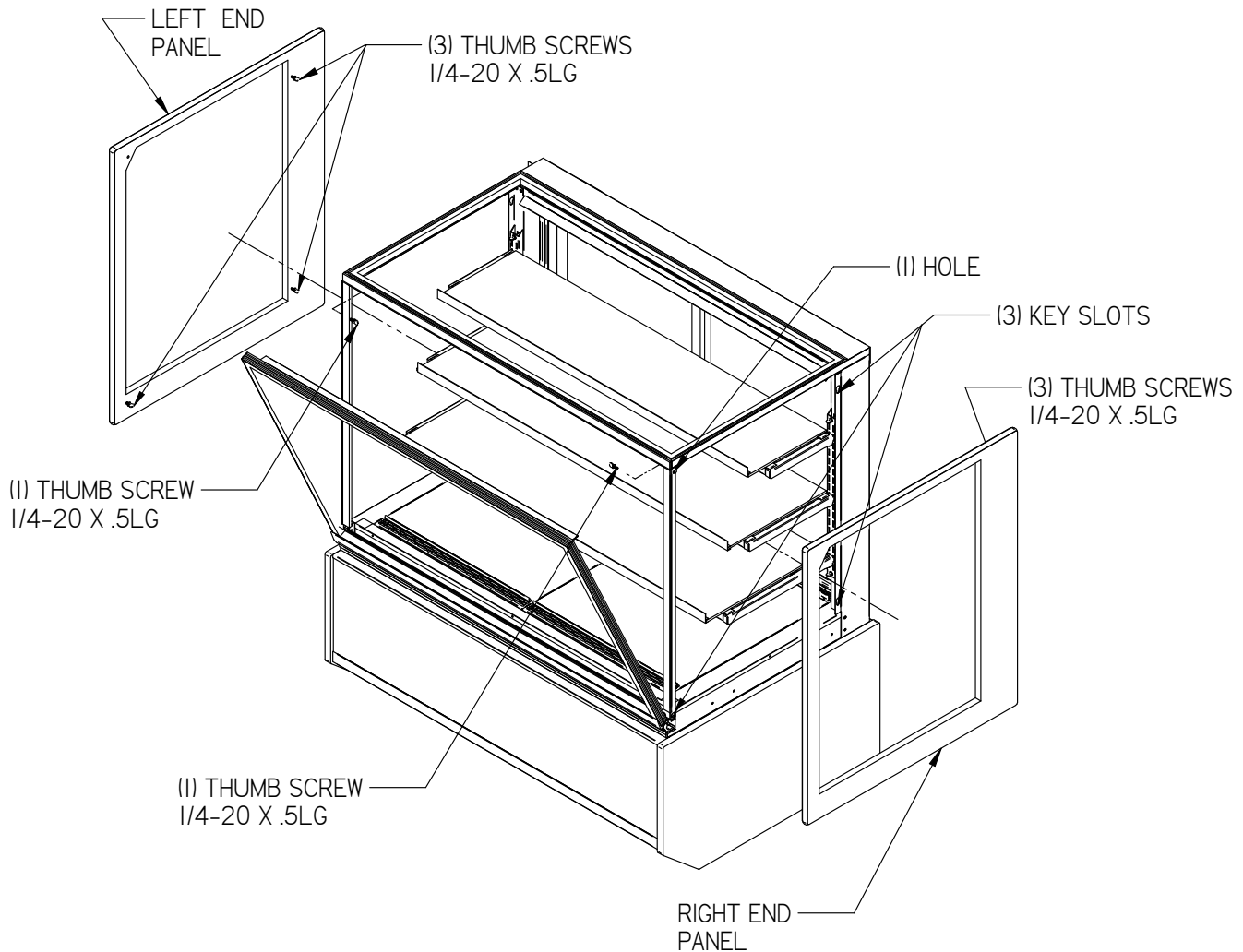

End Glass is shipped installed on Floor model units.

1. On each side of case there are (3) keyhole mounting slots for easier installation of glass. There is (1) mounting hole in the front top corner of case to prevent glass from accidentally popping off of end of case.
2. Screw (3) thumb screw about half way into end panel in location of the keyholes in case as shown.
3. Align end panel thumb screws with keyholes and hook end panel on to case. Do not tighten thumb screws.
4. Align the mounting hole in top front corner of case with top front hole in end panel and attach with 1/4-20 x .5LG thumb screw
5. Tighten all (4) thumb screws by hand.
6. Remove end panels in reverse order.

(8) SHELVING INSTALLATION AND REMOVAL

8.1 SHELF BRACKETS AND SUPPORTS

NOTE: Different shelf sizes and quantities are optional from factory so shelf bracket quantity and size may vary, but procedure is the same.

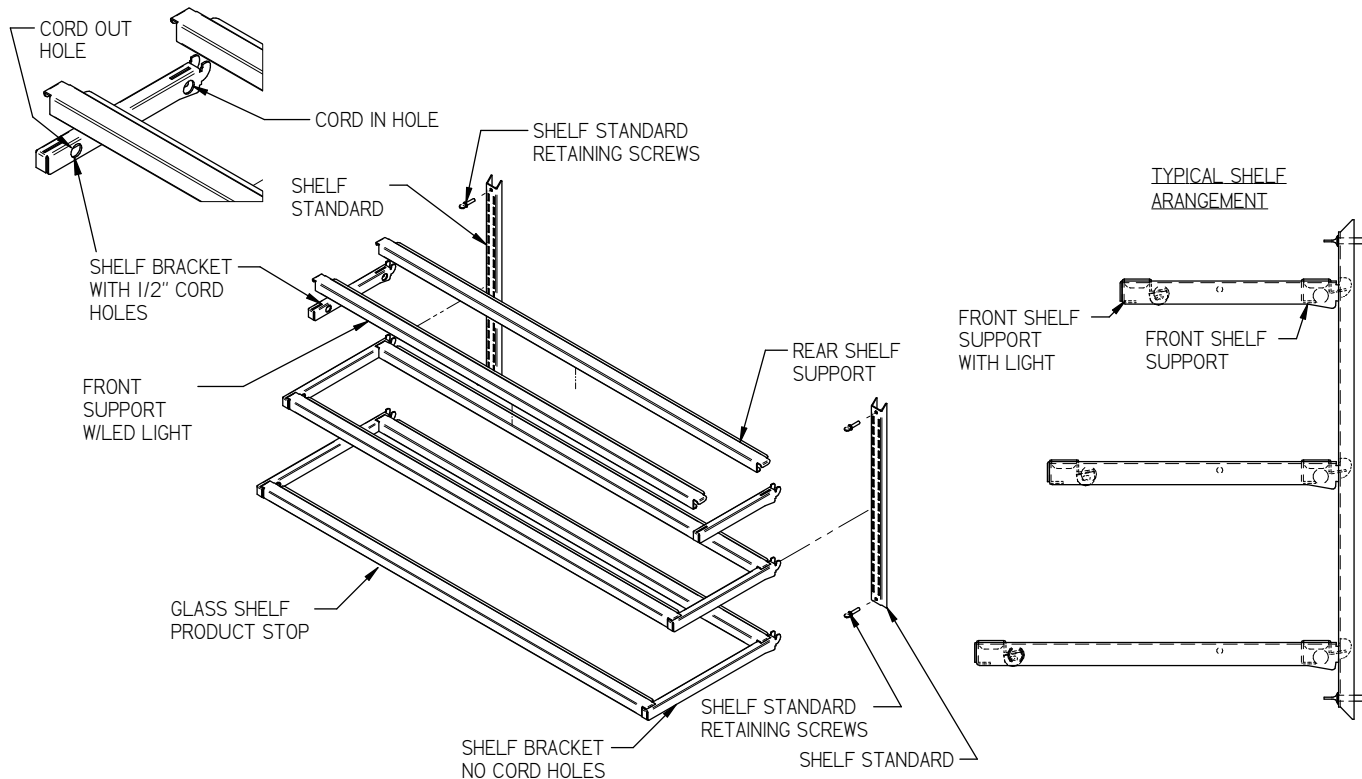

1. Turn the light switch to the off position. Remove rear doors as described in the "Rear Door Removal" section of this manual to allow access to interior of case.
2. Follow the instruction in the illustration below. Starting with the longest brackets for bottom shelf insert (1) of the (2) shelf brackets in the desired shelf standard slot on one side of the case. Place the long second shelf bracket in the same shelf standard slot on the opposite end of case. Important; The bracket with the 1/2 hole must be on the light cord side of case.
3. Repeat procedure for middle shelf brackets and the shortest top brackets. NOTE: Different shelf sizes and quantities are optional from factory so shelf bracket quantity and size may vary, but procedure is the same.
 1. Tilt shelf bracket upward and install shelf bracket hook into desired slot.
 2. Lift shelf bracket hook up behind back of shelf standard and rotate the shelf bracket downward until desired shelf bracket tab rests on front of shelf standard.
 3. Bracket can be either flat 0 degrees 5 degree downward tilt as shown.

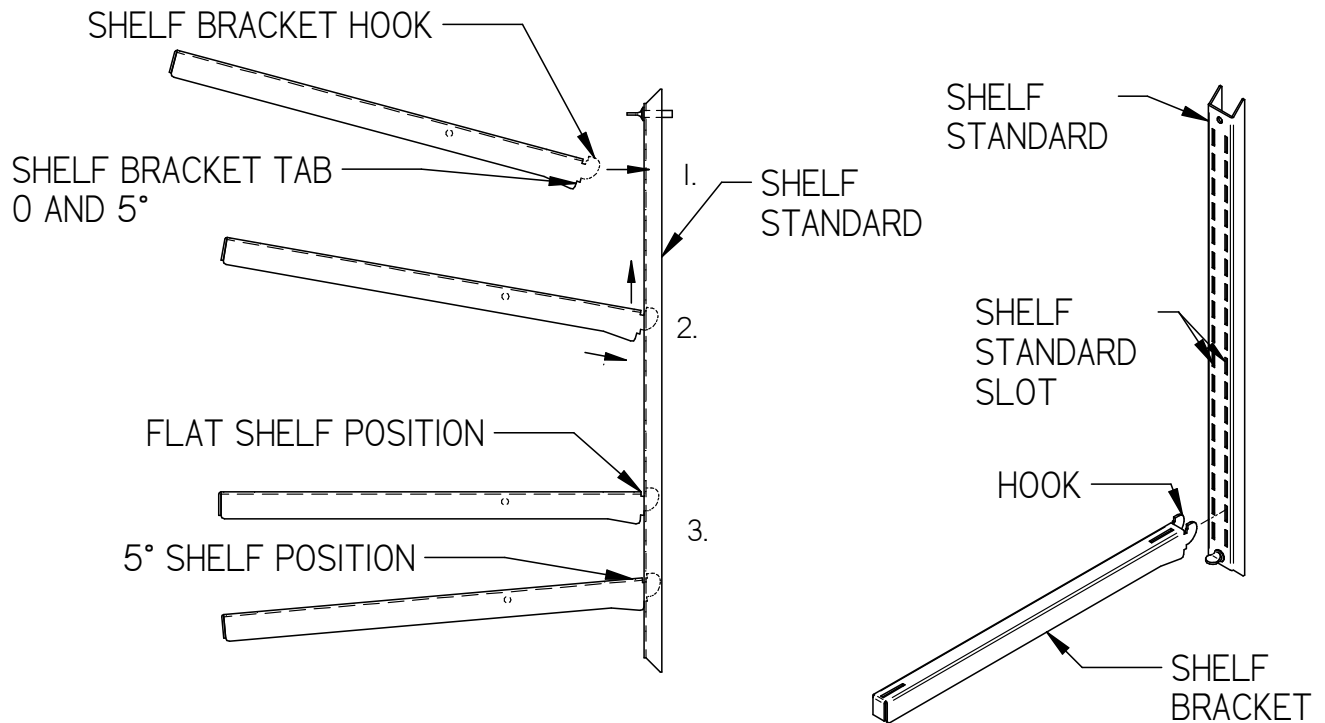

4. Once all shelf brackets are installed in desired position run each shelf light cord into $\frac{1}{2}$ hole in back of shelf bracket and out the $\frac{1}{2}$ " hole in the front of shelf bracket. The shelf light cord length can be adjusted by pulling out cord from cord grommet or pushing cord back into cord grommet.
5. Install front shelf supports with LED lights on to shelf brackets. All shelf supports with the lights are the same. The LED light must be facing towards back of case. Hook shelf support end flanges into front notch of shelf brackets on each side of case.
6. Install rear shelf supports with no lights on to shelf brackets. All shelf supports with no lights are the same. The flange on shelf support should be facing towards back of case. Hook shelf support end flanges into rear notch of shelf brackets on each side of case
7. Push shelf light cords into end of LED light. NOTE: Do not plug cord in backwards. There are (2) humps on end of cord that must align with humps in end of LED light. Plugging in the cord upside down will Damage LED light strip.
8. Manage desired cord lengths by pulling out cord from cord grommet or pushing cord back into cord grommet.

NOTE: Cords always remain in case they are not removable.

Special Length Shelf Installation

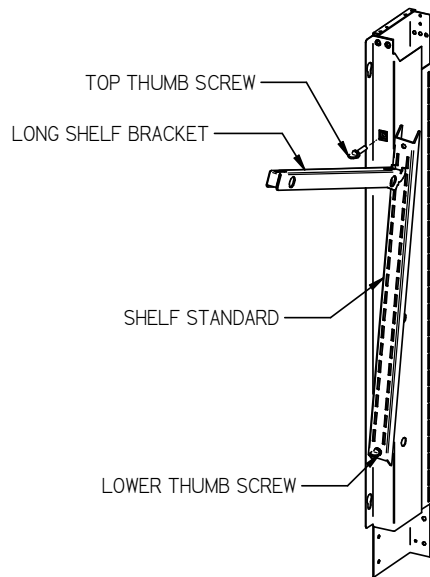

If the top shelf has long brackets and needs to be placed in top shelf standard notch position the shelf bracket may hit top panel or divider panel when trying to install it. If top slot is required install bracket as follows:

1. Remove the shelving from cases.
2. Loosen bottom thumb screw (do not remove)
3. Remove top thumb screw
4. Rotate the shelf standard towards center of case until the shelf bracket can be slipped into slots of standard.
5. Once shelf bracket is in place, rotate the shelf standard back to vertical position and reinstall top thumb screw and tighten.
6. Tighten lower thumb screw and install shelving as described in shelving installation.

LED Light Plug Connection

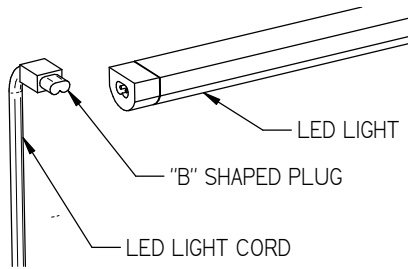

NOTICE: The plug must be inserted in correct orientation into LED light. LED light will not light if Connecting plug into LED light upside down. It may also cause LED light failure.

Look at the end of the plug and the receptacle of LED light. On one side of the LED plug there are two bumps and the other side there is a flat. (Similar to the letter B shape). The LED light has the same configuration. The shapes must align correctly when inserting LED plug into the LED light.

(9) FRONT AND REAR DOORS REMOVAL

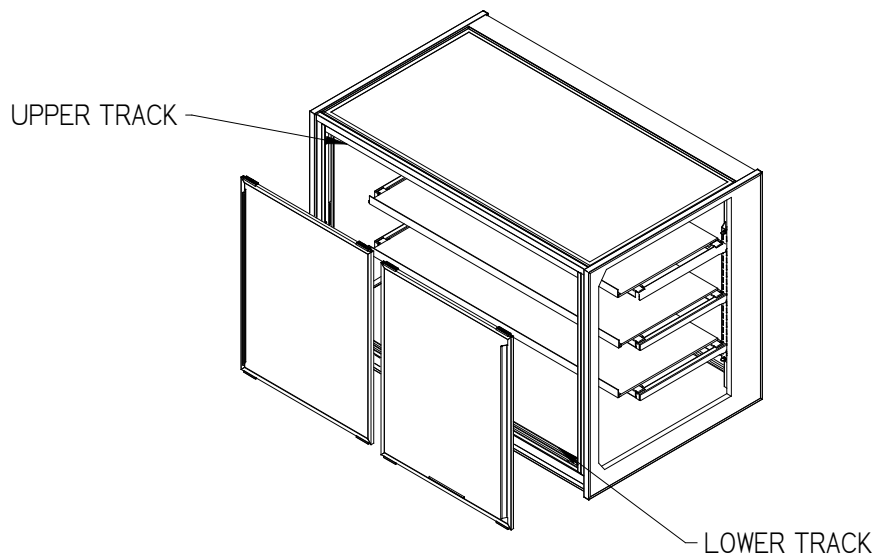
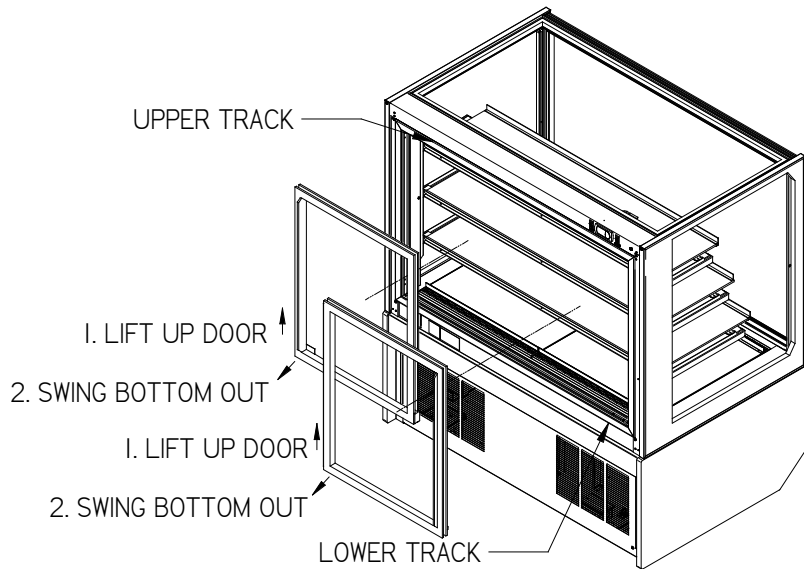

1. Start with the outer door and lift the door upward until the bottom edge of door clears the lower track and then swing the bottom of the door outward and down out of upper track.

2. After the outer door is removed repeat the procedure for the inner door.
3. Reverse this procedure for door reinstallation. Rear doors are not interchangeable.

(10) CONTROL OPERATION

▲NOTICE▲

Load items at 170°F or warmer. At time of loading, items stocked in unit **MUST** be pre-heated at 170°F or warmer.

The controls are found on the back of the unit just below the rear door track.

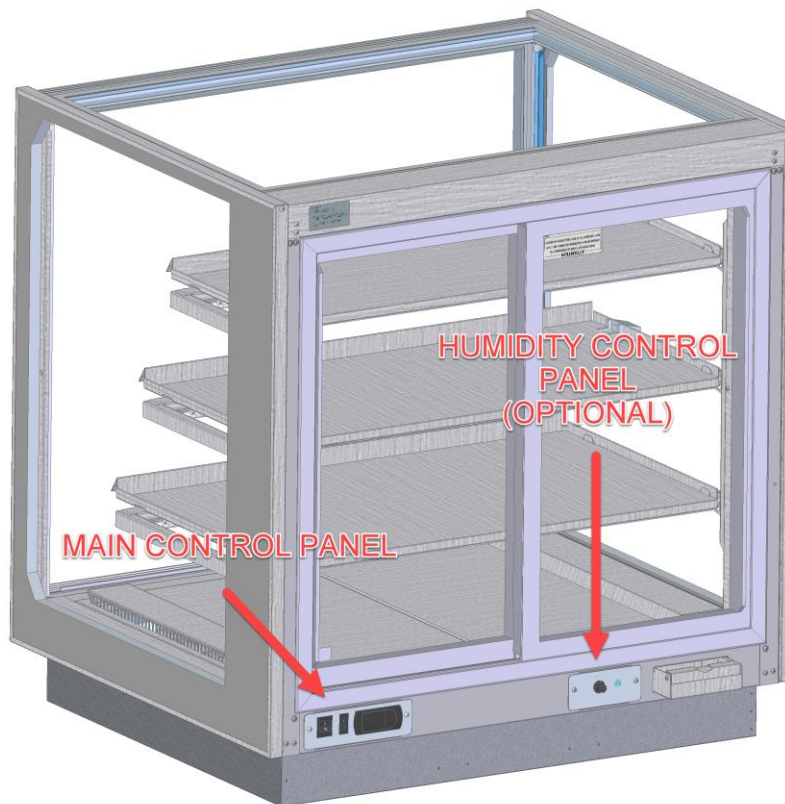

<u>CONTROL</u>	<u>PURPOSE</u>
POWER ON/OFF	POWER ENTIRE UNIT OFF OR ON; TURNS OFF ALL LIGHTS, HEATERS, AND CONTROLS
LIGHTS ON/OFF	TURN ALL LIGHTS ON OR OFF
AIR TEMPERATURE	ADJUST INTERNAL CASE TEMPERATURE, POWER ON/OFF AIR HEATING SYSTEM.
HUMIDITY (OPTIONAL)	ADJUST INTERNAL HUMIDITY LEVEL OF CASE. LIGHT ON INDICATES THAT WATER PAN IS DRY

10.1 Air Temperature Control

Use the following procedure to adjust the control setpoints.

ADJUSTMENT

- ▲ Power & set point up adjust
- Set point adjust mode
- ▼ Set point down adjust

- Power
- ▲ Hold 3 seconds to start system if off
- ▲ Hold 3 seconds to shut down system if on

- Temp Adjust
- Hold for 3 seconds to enter set point adjust mode
- ▲ Adjusts system to warmer setting while in set point mode
use higher settings for warmer temps - eg. "6" instead of "5"
- ▼ Adjusts system to colder setting while in set point mode
use lower settings for lower temps - eg. "4" instead of "5"

DISPLAY

- Heater on
- Alarm active

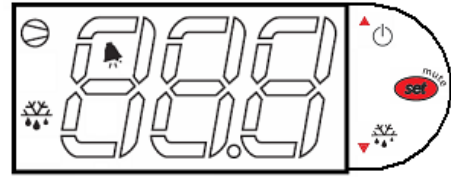

Display Reads

In normal operation the Display reads control setting
 "OFF" - System is off
 "1" thru "9" - Currently selected set point (system is on)
 "E" followed by any character - Error code see Federal owner's manual
 Some controls display green characters, some display red,
 the control is operating normally in either case

If control emits beeping noise press and release to mute
 Read error code and check Federal owner's manual to determine
 if service is required

Error code E0=Temperature probe disconnected or failed.

The temperature controllers each reference one temperature probe that is mounted in the deck or shelf depending on the control. Do not locate the probe to a different position.

Temperatures are digitally controlled via factory settings 1-9. Setting "1" provides the coolest surface temperatures while setting "9" will provide the warmest. See table below for the temperature of each setting.

CONTROL SETTING	INTERNAL CABINET TEMPERATURE
1	130°F
2	135°F
3	140°F
4	145°F
5	150°F
6	155°F
7	160°F
8	165°F
9	170°F

10.2 Humidity Control And Pan Operation (When Equipped)

Rotate the knob clockwise to a higher setting to increase internal cabinet humidity and counterclockwise to reduce the humidity level.

Different air temperatures will result in different relative humidity values for the same number setting of the control.

Turning the control to “OFF” does not prevent the addition of humidity. This setting turns off the water pan heater that is required to increase humidity levels past what the standard air heating element does.

To eliminate all humidity generation, simply do not add water to the pan.

See also the cleaning section of this manual for details on how to remove hard water residue.

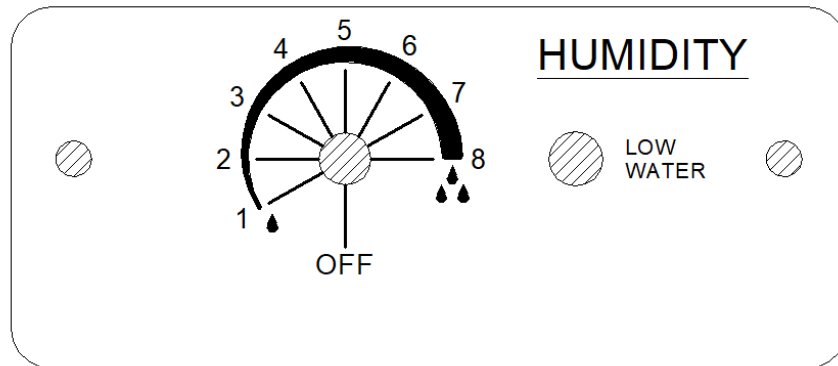

To start using the humidity pan first check that the drain valve is in the closed position. The valve is located on the end of the drain hose underneath the display cabinet. If equipped with a rear panel, this panel must be removed to access the hose and valve.



Pull out the sliding cover and add water until the pan is visibly full. The amount of time the water will last in the pan depends on the air temperature and humidity level settings chosen. At max air and humidity settings, the water should last roughly 4hrs prior to needing refilled. When the pan needs to be refilled the blue indicator light on the humidity control panel will light up. Water may be added prior to this, but it is not necessary.

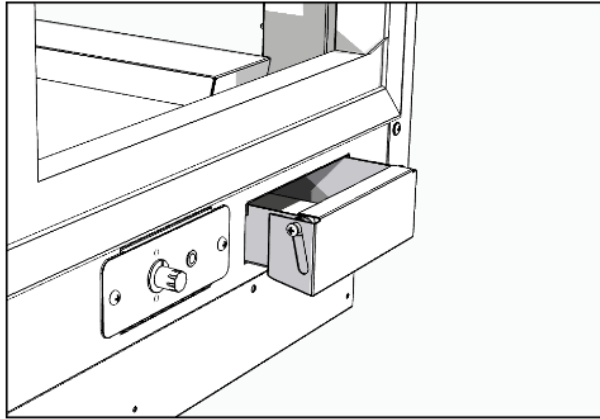
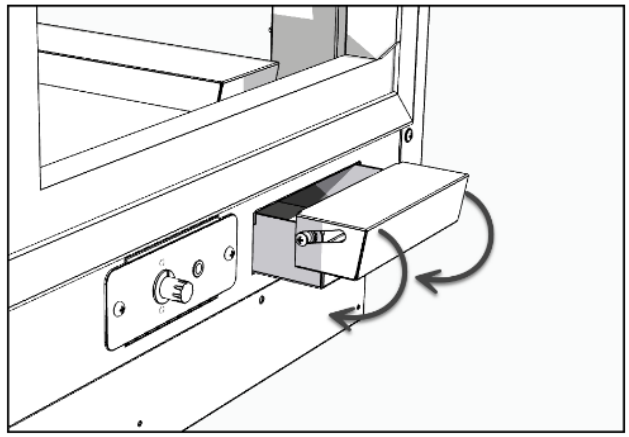
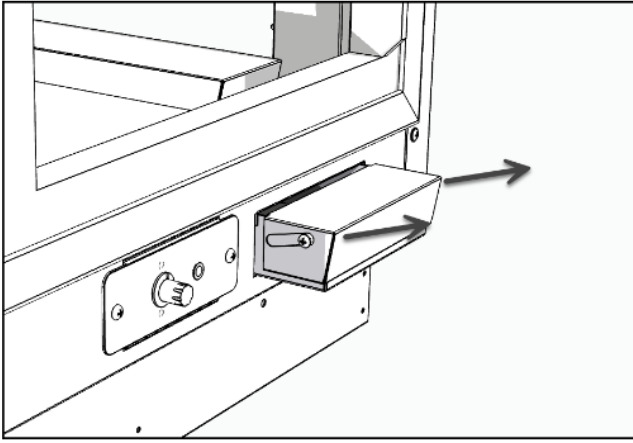

10.3 Typical Humidity Conditions

The following table represents approximate humidity levels that the humidity package can generate at various control settings.

Temperature Control Setting	Temperature [°F]	Temperature [°C]	Relative Humidity at max highest setting
1	130	54.4	70%
5	150	65.6	40%
9	170	76.7	20%

(11) FOOD PACKAGING RECOMMENDATIONS





This merchandiser is designed to be used with pre-packaged product only. All food items placed in the merchandiser must be packaged. No foods should be placed in the merchandiser without packaging.

▲NOTICE▲

Load items at 150°F or warmer. At time of loading, items stocked in unit MUST be pre-heated at 150°F or warmer.

Not all packaging is compatible with this merchandiser. Any packaging material with a rating of less than 200°F should not be used.

Typically, polypropylene (recycle code 5) works well, but check with the manufacturer first to get an accurate assessment of the application.





 <u>DO NOT USE</u> the following packaging materials:	
Recycle Code	Material Name
	Polyethylene terephthalate
	High-density polyethylene
	Polyvinyl chloride
	Low-density polyethylene

Materials listed in the table above will not survive the high temperature conditions of this merchandiser.

(12) CLEANING INSTRUCTIONS

12.1 DAILY CLEANING

The case should be cleaned thoroughly, as described in the weekly cleaning section before it is used for the first time.

	NOTICE: Avoid splashing or soaking any electrical components with water to prevent electrical damage to the case.
	NOTICE: Shut off power switch and remove all product from case. Allow enough time for the unit to reach room temperature before proceeding with cleaning.
	NOTICE: Remove all product from case before proceeding with cleaning procedure.
	NOTICE: This case is not designed to be cleaned by flushing.

Note: For major spills or foreign material buildup perform the weekly cleaning instructions.



Note: Detergents are not recommended and do not use abrasive cleaners or pads to prevent scratching of surfaces.

1. Clean all foreign materials from the door opening.
1. Wipe complete interior of both the upper & lower areas of case using a damp cloth.
2. The remaining exterior surface should be wiped down using any ammoniated cleaners or soapy warm water.

12.2 WEEKLY CLEANING

This procedure is recommended on a weekly basis. It may need to be performed more often if necessary, to maintain a clean, sanitary case. The case should be cleaned to this procedure before using the first time.

	NOTICE: Avoid splashing or soaking any electrical components with water to prevent electrical damage to the case.
---	---

	<p>NOTICE:</p> <p>Shut off power switches and remove all product from case. Allow enough time for the unit to reach room temperature before proceeding with cleaning.</p>
	<p>NOTICE:</p> <p>Remove all product from case before proceeding with cleaning procedure.</p>
	<p>NOTICE:</p> <p>This case is not designed to be cleaned by flushing.</p>

1. Side, and rear door glass can be cleaned with common window cleaners.
2. Remove interior shelving and display deck from unit as described in the “Shelving Installation and Removal” section of this manual.
3. Clean all shelves, shelf supports, shelf light deflectors, shelf brackets, shelf standards using warm soapy water and a brush. Rinse thoroughly and allow to dry.
4. Remove the display deck and clean using warm soapy water and a brush. Rinse thoroughly and allow to dry.
5. Clean the entire interior of the case using warm soapy water. Wipe off all soapy water with a damp cloth and allow to dry. (DO NOT use solvents such as Acetone, Benzene, Carbon Tetrachloride, and Lacquer Thinners)
6. Reassemble all components in reverse order.
7. The exterior surfaces should be wiped down using any ammoniated cleansers or warm soapy water.

12.3 CLEANING THE OPTIONAL HUMIDITY PAN

The humidity pan will need to be cleaned on a regular basis. The frequency of the cleaning required is directly related to the hardness of water being added to the pan. See table below.

Water Hardness	Cleaning Interval Recommendation
0 gpg	Typically not required
1-9 gpg	Once per month
10-20 gpg	Twice per month
20+ gpg	Weekly

gpg = grains per gallon

To clean the humidity pan:

1. Locate the drain hose protruding from underneath the case. The rear panel will need to be removed if included.
2. Using a 2.5gal bucket or other container, open the drain valve and let the water drain completely into the bucket.
3. Close the drain valve to prevent any further flow.

4. Add a 50% white vinegar (5% acidity) 50% water solution to the pan until it is full.
5. Turn the humidity up to the highest setting.
6. Allow the unit to run for 30mins to dissolve the scale buildup in the pan.
7. Drain the solution into a bucket and discard using the same method described for remaining water above.
8. For extreme scale buildup this procedure may need to be repeated, or full strength vinegar may be required.

Other lime scale removal products may be used for this process, but anything used should be food safe.

(13) SERVICE

Service Information

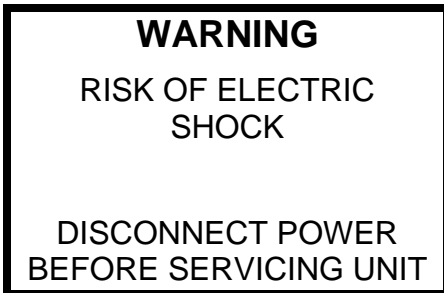

Before any service work is performed on the case, make sure all power is disconnected to the case.

To find a service company in your area, please visit our website at <https://federalind.com/support-service/service-rep-locator>. There you can also find self-service tools to help you get the answers you need faster!

For warranty service requests and all technical support, including compressors and other service parts please contact:

- Phone: (833) 238-8168
- Email: techservice@partstown.com



Federal Industries has partnered with Parts Town for ALL Non-Warranty Part Identification, Pricing, Lead Times, Orders & Freight Quotes. Please contact Parts Town directly if you need parts:

- Website: Partstown.com
- Email: CustomerService@Partstown.com
- Phone: 833-809-8188

(14) SALE & DISPOSAL

14.1 OWNER RESPONSIBILITY

If you sell or give away your Federal Industries case you must make sure that all safety labels and the Installation-Service Manual are included with it. If you need replacement labels or manuals, Federal Industries will provide them free of charge. Contact the customer service department at Federal Industries at (800) 356-4206.

The customer service department at Federal Industries should be contacted at the time of sale or disposal of your case so records may be kept of its new location.

(15) TROUBLESHOOTING

Pre-Service Checklist

You may avoid the cost and inconvenience of an unnecessary service call by first reviewing this checklist of frequently encountered situations that can cause unsatisfactory case performance.

Case Does Not Operate

Check for disconnected power supply.

Check for tripped breaker on blown fuse.

Check that the thermostat display is on and is not displaying an error.

Lights Do Not Operate

Check that light switch is on.

Check for tripped breaker or blown fuse.

Check that light cords are plugged in correctly to sockets. Check connector on LED light, and connector on

Temperature is too low

Increase control setpoint

Check supply voltage to case is above 208V

Look for HVAC discharge vents, fans, and other possible air disruptions.

Temperature is too high

Turn down control setpoint

Check the control for errors and contact service

Control Error

Turn the main power switch to off to power down the unit

Wait 10s, and power the unit back on

Wiring Diagrams

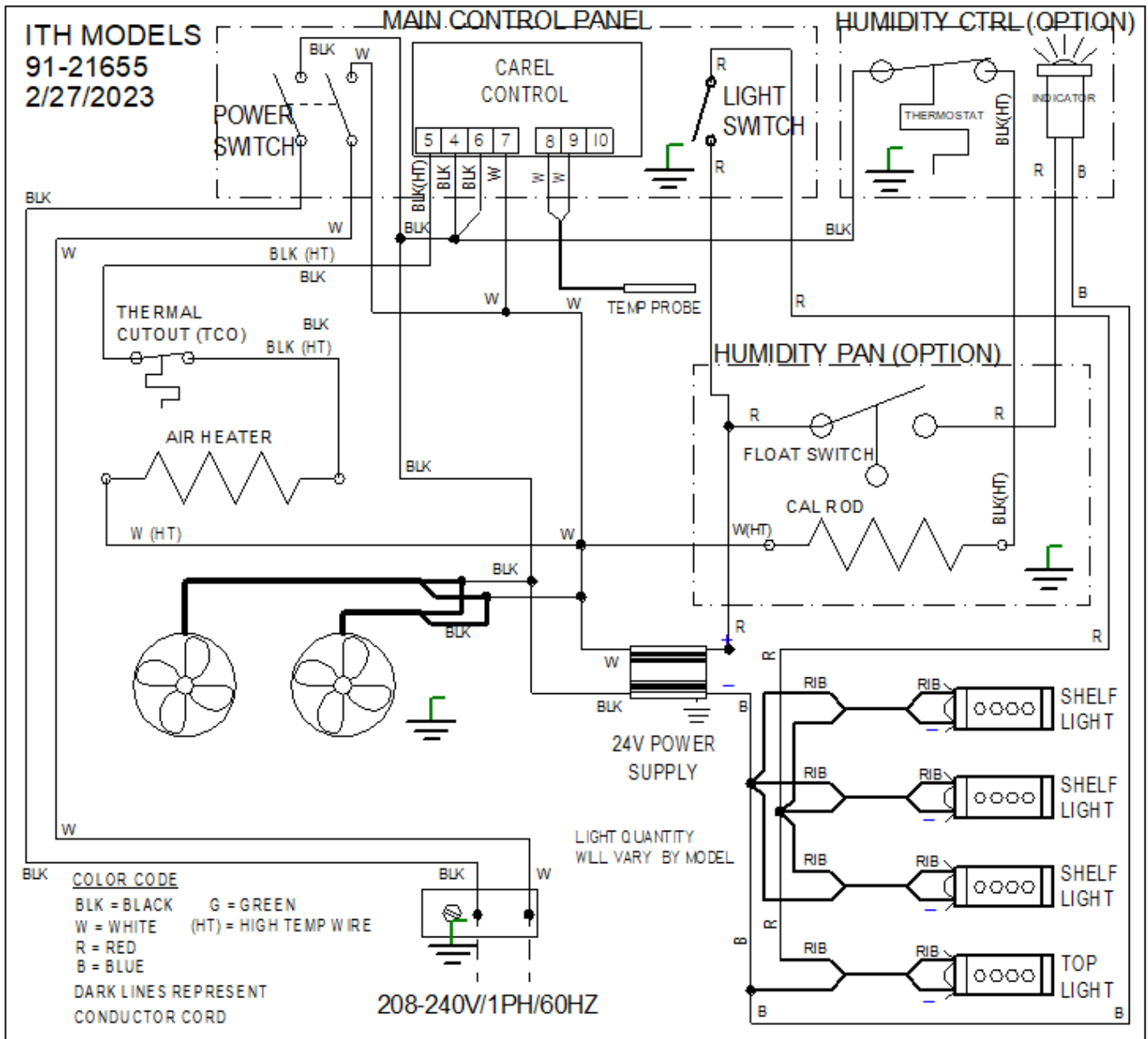

(16) SERVICE PARTS

ELECTICAL COMPONENTS

MODELS	LIGHT SWITCH	POWER SWITCH	LIGHT POWER SUPPLY	LIGHT 24V LED STRIP	SHELF LIGHT CORD	MAIN WIRING DIAGRAM	MAIN WIRE HARNESS
ITH36	4I-11066	4I-18186	39-20555	42-20870-29C35	43-20475	9I-21655	43-2164I
ITH48	4I-11066	4I-18186	39-20555	42-20870-40C35	43-20475	9I-21655	43-2164I
ITH60	4I-11066	4I-18186	39-20555	42-20870-51C35	43-20475	9I-21655	43-2164I

AIR HEATING COMPONENTS

MODELS	AIR HEATER	FAN	FAN CORD	ELECTRONIC CONTROL	TEMPERATURE PROBE	THERMAL OVERLOAD PROTECTOR
ALL	40-21532	4I-21617	43-11171	32-19865-20	32-21046	4I-17129

HUMIDITY PACKAGE COMPONENTS

MODELS	CONTROL ASSEMBLY	PAN ASSEMBLY
ALL	SA6I24-2	SA6I22

HUMIDITY PACKAGE CONTROL COMPONENTS

MODELS	CONTROL	INDICATOR LIGHT	DECAL
ALL	4I-21646	42-21629	9I-21649

HUMIDITY PAN COMPONENTS

MODELS	PAN	PAN LID	HEATER	DRAIN TUBE	DRAIN VALVE	HOSE CLAMPS	FLOAT SWITCH	THERMOSTAT PROBE BRACKET	ENCLOSURE GASKET
ALL	SA6I2I	M2I860	40-21598-3	I5-21606	84-21608	8I-21609	4I-2162I	M2I832	I6-12426

GLASS COMPONENTS

MODELS	FRONT GLASS / PLASTIC ON SS	TOP GLASS	END GLASS CLEAR L.H. SS TRIM. W/SCREWS	END GLASS CLEAR R.H. SS TRIM W/SCREWS	END GLASS REFL. L.H. SS TRIM W/SCREWS	END GLASS REFL. R.H. SS TRIM W/SCREWS	FRONT GLASS MAGNET SIDE
ITH3626	5I-20598-4	5I-20599-4	SA6I38-IL	SA6I38-IR	SA6I38-3L	SA6I38-3R	64-20476-5
ITH4826	5I-20598-5	5I-20599-4	SA6I38-IL	SA6I38-IR	SA6I38-3L	SA6I38-3R	64-20476-5
ITH6026	5I-20598-6	5I-20599-4	SA6I38-IL	SA6I38-IR	SA6I38-3L	SA6I38-3R	64-20476-5
ITH3634	5I-20598-1	5I-20599-1	SA6I38-L	SA6I38-R	SA6I38-2L	SA6I38-2R	64-20476-4
ITH4834	5I-20598-2	5I-20599-2	SA6I38-L	SA6I38-R	SA6I38-2L	SA6I38-2R	64-20476-4
ITH6034	5I-20598-3	5I-20599-3	SA6I38-L	SA6I38-R	SA6I38-2L	SA6I38-2R	64-20476-4

REAR DOORS

MODELS	DOOR LEFT CLEAR	DOOR RIGHT CLEAR	DOOR LEFT REFLECTIVE	DOOR RIGHT REFLECTIVE
ITH3626	53-20467-4	53-20468-4	53-20467-4A	53-20468-4A
ITH4826	53-20467-5	53-20468-5	53-20467-5A	53-20468-5A
ITH6026	53-20467-6	53-20468-6	53-20467-6A	53-20468-6A
ITH3634	53-20467-1	53-20468-1	53-20467-1A	53-20468-1A
ITH4834	53-20467-2	53-20468-2	53-20467-2A	53-20468-2A
ITH6034	53-20467-3	53-20468-3	53-20467-3A	53-20468-3A

SHELF & DECK COMPONENTS

MODELS	S/S SHELF - 11" (NOT STANDARD FOR 26IN MODELS)	S/S SHELF - 14"	S/S SHELF - 17"	SHELF BRACKET FOR 11" SHELF	SHELF BRACKET FOR 14" SHELF	SHELF BRACKET FOR 17" SHELF	DISCHARGE DISPLAY DECK (LEFT)	INTAKE DISPLAY DECK (RIGHT - TEMP CONTROL SIDE)
ITH36	M21813-1	M21813-2	M21813-3	67-20621-1L	67-20621-2L	67-20621-3L	SA6126-1	SA6120-1
ITH48	M21813-4	M21813-5	M21813-6	67-20621-1L	67-20621-2L	67-20621-3L	SA6126-2	SA6120-2
ITH60	M21813-7	M21813-8	M21813-9	67-20621-1L	67-20621-2L	67-20621-3L	SA6126-3	SA6120-3

REV	CHANGE RECORD	APP'D	DATE	ECN#
-	INITIAL RELEASE	JTR	3/3/2023	3856
A	Added service parts, and humidity details.	JTR	5/4/2023	-

California Residents Only.

 **WARNING**

This product can expose you to chemicals including chromium which is known to the State of California to cause cancer and birth defects or other reproductive harm. For more information go to www.P65Warnings.ca.gov