

E3670-20  
REV 0 3/13/26



*The Signature of Quality®*

**FEDERAL INDUSTRIES  
LMD4878, LMD7278, LMD9678  
INSTALLATION & OPERATIONS MANUAL**



**KEEP THIS MANUAL FOR FUTURE REFERENCE**

Engineering and technical data are subject to change without notice.

FEDERAL INDUSTRIES  
Toll Free 1(800) 356-4206

P.O. Box 290  
WI Phone (608) 424-3331

Belleville, WI 53508  
Fax: (608) 424-3234

---

---

# Contents

---

---

A) INTRODUCTION .....	5
REGISTRATION & SERIAL NUMBER .....	5
B) WARNING LABELS & SAFETY INSTRUCTIONS .....	6
C) REFRIGERATION WARNING .....	7
INSTALLATION-REPAIR-DECOMMISSIONING .....	7
D) BASE COMPONENT LAYOUT .....	14
E) ELECTRICAL & REFRIGERATION DATA .....	15
F) INSTALLATION .....	15
Inspection For Shipping Damage .....	16
Locating The Display Case .....	16
Remote Units .....	16
Maximum Releasable Charge .....	18
Removing Case From Shipping Skid .....	19
Removing Packaging Material .....	19
Lifting and Moving Case .....	20
Single Case Installation .....	21
Leveling the Case .....	21
Sealing Unit to The Floor .....	21
Multiple Case Lineup Installation .....	22
Two Cases Connected to Single Remote Condenser .....	23
Floor Preparation .....	24
Joining and Leveling Line Up .....	24
Sealing all Unit to The Floor .....	26
Electrical Connection .....	26
Permanent Connected (Standard) .....	26

Panel Removal for Electrical Access .....	28
Condensate Drain Hose (Standard).....	29
Condensate Pump (Optional) .....	29
Shelving Installation.....	30
Shelf Lights .....	31
G) OPERATING INSTRUCTIONS .....	32
Control Description .....	32
Electronic Temperature Control Operation.....	33
Operation.....	33
Defrost Cycle .....	33
Powering on control .....	34
Adjusting the set point .....	35
Entering manual defrost mode.....	35
Refrigerant detection and mitigation system .....	37
Refrigerant Detection System (RDS) Location .....	38
Night Curtain Operation .....	39
Security Cover Operation (Optional).....	40
H) INITIAL START-UP .....	41
Placing Product into Case .....	41
I) MAINTENANCE .....	42
Top Light Bulb Replacement .....	42
cleaning Condenser Coil.....	42
J) CLEANING INSTRUCTIONS .....	43
Daily Cleaning .....	43
K) SERVICE INFORMATION .....	46
Special Service Situations .....	47
Pre-Service Checklist.....	48
L) SALE & DISPOSAL .....	49

M)	REFRIGERATION OPERATION .....	50
	Electronic Expansion Valve (EEV) .....	51
	EEV Controller Settings .....	51
N)	PARTS LIST .....	52
O)	CASE WIRIG DIAGRAMS .....	54
	LMD48, 72, 96 .....	54

---

---

## A) INTRODUCTION

---

---

Thank you for purchasing a Federal Industries display case. This manual contains important instructions for installing and servicing the LMD Models. A repair parts list and wiring diagrams are also included in the manual. Read all of these documents carefully before installing or servicing your case.



### NOTICE

**Read this manual before installing your case. Keep this manual and refer to it before doing any service on the equipment. Failure to do so could result in personal injury or damage to the case.**



### NOTICE

**Installation and service of the electrical components in the case must be performed by a licensed electrician.**

**The portions of this manual covering components contain technical instructions are intended only for persons qualified to perform electrical work.**



### DANGER

**Improper or faulty hookup of electrical components in the case can result in severe injury or death.**

**All electrical wiring hookups must be done in accordance with all applicable local, regional, or national standards.**

## REGISTRATION & SERIAL NUMBER

It's important to keep a record of the model and serial number of your merchandiser for warranty and part identification. Please write them here for your quick reference.

**Register your product online!** Visit our website at [www.federalindustries.com](http://www.federalindustries.com) and register your product today.

Case Model \_\_\_\_\_ Serial Number \_\_\_\_\_

We're here to provide you with the best possible experience with your new product, however, we cannot cover everything about your merchandiser in this manual, so if you have any additional questions or issues, please see the SERVICE INFORMATION PAGE to find who you should contact.

---

---

## B) WARNING LABELS & SAFETY INSTRUCTIONS

---

---



This is the safety-alert symbol. When you see this symbol on your case or in the manual, be alert to the potential for personal injury or damage to your equipment.

Be sure you understand all safety messages and always follow recommended precautions and safe operating procedures.



### NOTICE TO EMPLOYERS

**You must make sure that everyone who installs, uses, or services your case is thoroughly familiar with all safety information and procedures.**

Important safety information is presented in this section and throughout the manual. The following signal words are used in the warning and safety messages:

**DANGER:** Severe injury or death will occur if you ignore the message.

**WARNING:** Severe injury or death can occur if you ignore the message.

**CAUTION:** Minor injury or damage to your case can occur if you ignore the message.

**NOTICE:** This is important installation, operation, or service information. If you ignore the message, you may damage your case.

---

---

The warning and safety labels shown throughout this manual are placed on your Federal Industries case at the factory. Follow all warning label instructions. If any warning or safety labels become lost or damaged, call our customer service department at 1(800) 356-4206 for replacements.

---

---

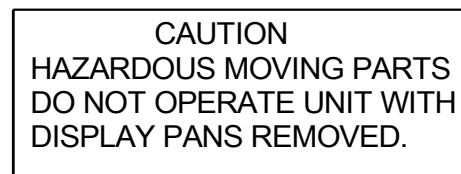
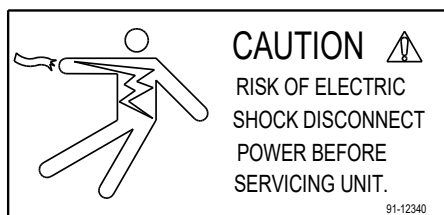

***This label is located on removable electrical panels. This label is located below near moving parts***

---

---

## C) REFRIGERATION WARNING

---

---

### **INSTALLATION-REPAIR-DECOMMISSIONING**

Be sure you understand all safety messages and always follow recommended precautions and safe operating procedures.



#### **DANGER**

**Risk of fire or explosion. Flammable refrigerant used. To be repaired only by trained service personnel. Do not puncture refrigerant tubing. Dispose of properly in accordance with federal or local regulations.**

Consult repair manual/owner's guide before attempting to service this product. All safety precautions must be followed.

Follow handling instructions carefully in compliance with national regulations.

Auxiliary devices which may be ignition sources shall not be installed in the ductwork, other than auxiliary devices listed for use with the specific appliance.

Do not store explosive substances (such as aerosol cans with a flammable propellant) in this case.

Do not use an electrical appliance **INSIDE** the food storage compartments unless its type is recommended by manufacturer.

Flammable refrigerant type specified on case nameplate is on the serial label.

**APPLIES TO R290 REFRIGERANT MODELS ONLY!** Contains a charge of R290 refrigerant with a lower flammability limit (LFL) of  $.038\text{kg/m}^3$ . See table for amount of charge.

**APPLIES TO R454C REFRIGERANT MODELS ONLY!** Contains a charge of R454C refrigerant with a lower flammability limit (LFL) of  $.0.286\text{kg/m}^3$ . See data plate for amount of charge.

#### **WARNING**

- Do NOT use means to accelerate the defrosting process or to clean, other than those recommended by the manufacturer
- The appliance **SHALL** be stored in a room without continuously operating ignition sources  
For example: open flames, an operating gas appliance, or an operating electric heater
- Do NOT pierce or burn.
- Be aware that refrigerants may not contain an odor

## MISE EN GARDE

-Ne pas utiliser de moyens autres que ceux recommandés par le fabricant pour accélérer le processus de dégivrage ou pour nettoyer l'appareil.

-L'appareil doit être entreposé dans un local ne contenant pas de sources d'inflammation permanentes (flammes nues, appareil à gaz ou dispositif de chauffage électrique en fonctionnement, par exemple).

-Ne pas percer ou brûler.

-Attention, les fluides frigorigènes peuvent ne pas dégager d'odeur.

### Qualification:

All refrigeration and electrical maintenance, service, and repair must be performed by a Certified Technician that is trained in the required flammable refrigerants safety procedures. Technicians must read the entire section **Error! Reference source not found.** section of this manual.

Work requiring qualification includes but is not limited to the following:

- a) breaking into the refrigerating circuit.
- b) opening of sealed components.
- c) opening of ventilated enclosures.

### Required Safety Checks:

Prior to beginning work on systems containing FLAMMABLE REFRIGERANTS, perform the following safety checks to ensure that the risk of ignition is minimized prior to conducting work on the system.

- Discharge all capacitors using safe, non-sparking method to prevent accidental arcing.
- Ensure no live electrical components or wiring are exposed during charging, recovering or purging.
- Confirm continuity of earth bonding.
- Ensure all personnel (direct, contracted, etc.) in the area are informed of the nature of the work being performed.
- Ensure the work area is open or adequately ventilated.
  - Ensure ventilation is maintained during work.
  - Ventilation should disperse any released refrigerant and preferably discharge it externally to atmosphere.
  - Work in confined spaces shall be avoided.

- Survey the surrounding area to ensure there are NO flammable hazards, ignition sources, or other unsafe conditions present.
  - All possible ignition sources, including cigarette smoking, shall be kept sufficiently far away from the site of installation, repairing, removing and disposal, during which refrigerant can potentially be released to the surrounding area.
  - “NO Smoking” signs shall be posted and visible.
- Check the area with an appropriate refrigerant detector prior to and during work to ensure the technician is aware of potentially toxic or flammable vapors.
  - Ensure that the leak detection equipment being used is suitable for use with all applicable refrigerants (e.g., non-sparking, adequately sealed, or intrinsically safe)
  - NOTE: The use of silicon sealants can inhibit the effectiveness of some types of leak detection equipment.
- Work shall follow a controlled procedure that prevents release or accumulation of flammable gas or vapor throughout the process.
- No person performing work to or near a REFRIGERATION SYSTEM that involves exposing any pipe work shall use any sources of ignition in such a manner that it may lead to the risk of fire or explosion.
- Verify the actual REFRIGERANT CHARGE is in accordance with the room size within which the refrigerant containing parts are installed.
- Verify the ventilation machinery and outlets are operating adequately and are not obstructed.
- Verify markings on the equipment continue to be visible and legible.
  - Markings and signs that are illegible shall be corrected.
- Verify refrigerating pipes and components are installed in a position where they are unlikely to be exposed to any substance which may corrode refrigerant containing

### **Hot Work Controls**

If any hot work is to be conducted on the refrigerating equipment or any associated parts,

- Recover or isolate refrigerant prior to beginning hot work (See part 0 of this section)
- Appropriate fire extinguishing equipment shall be made readily available before starting work.
- A dry chemical or CO<sub>2</sub> fire extinguisher should be adjacent to the charging area.
- The area shall be adequately ventilated before and during any hot work to safely disperse any released refrigerant.

### **Electrical Components**

- Electrical components being changed shall be suitable for the purpose and to the correct specification so as to minimize the risk of possible ignition due to incorrect parts.
  - At all times, the manufacturer’s maintenance and service guidelines shall be followed.
  - If in doubt, consult the manufacturer’s technical department for assistance.

- If a fault exists that could compromise safety, then no electrical supply shall be connected to the circuit until it is satisfactorily resolved. If the fault cannot be corrected immediately but it is necessary to continue operation, an adequate temporary solution should be used.

### **Repairs to sealed components**

- During repairs to sealed components, all electrical supplies shall be disconnected from the equipment being worked upon prior to any removal of sealed covers, etc.
  - If it is necessary to have an electrical supply to equipment during servicing, then a permanently operating form of leak detection shall be located at the most critical point to warn of a potentially hazardous situation.
- Measures shall be taken to ensure that work on electrical components does not alter the casing in such a way that it compromises its level of protection. This includes preventing:
  - Damage to cables;
  - Excessive number of connections;
  - Terminals not made to original specification;
  - Damage to seals;
  - Incorrect fitting of glands;
  - etc.
- Ensure that the apparatus is mounted securely.
- Ensure that seals or sealing materials have not degraded to the point that they no longer prevent the egress of flammable vapors.
- Replacement parts shall be in accordance with the manufacturer's specifications.

### **Repairs to intrinsically safe components**

Note: Intrinsically safe components do not have to be isolated prior to working on them

- Do not apply any permanent inductive or capacitance loads to the circuit without ensuring that this will not exceed the permissible voltage and current permitted for the equipment in use.
- Replacement parts shall be in accordance with the manufacturer's specifications to ensure that the risk of ignition is minimized,

### **Safe Detection of flammable refrigerants:**

Under no circumstances shall potential ignition sources be used in the searching for or detection of refrigerant leaks. A halide torch (or any other detector using a naked flame) shall not be used.

### **The following leak detection methods are deemed acceptable for all refrigerant systems:**

Electronic leak detectors may be used to detect refrigerant leaks but, in the case of FLAMMABLE REFRIGERANTS, the sensitivity might not be adequate or might need recalibration.

- Detection equipment shall be calibrated in a refrigerant-free area.
- Ensure that the detector is not a potential source of ignition and is suitable for the refrigerant used.

- Leak detection equipment shall be set at a percentage of the LFL of the refrigerant and shall be calibrated to the refrigerant employed, and the appropriate percentage of gas (25 % maximum) is confirmed.

Leak detection fluids are also suitable for use with most refrigerants but the use of detergents containing chlorine shall be avoided as the chlorine can react with the refrigerant and corrode the copper pipework. Examples of leak detection fluids are

- bubble method,
- fluorescent method agents.

If a leak is suspected, all naked flames shall be removed/extinguished.

If a leakage of refrigerant is found which requires brazing, all the refrigerants shall be recovered from the system, or isolated (by means of shut off valves) in a part of the system remote from the leak.

### **Removal and Evacuation:**

Prior to breaking into the refrigerant circuit for any purpose, the following procedure shall be adhered to due to the added flammability risk:

- a) Safely remove refrigerant following local and national regulations.
- b) Purge the circuit with oxygen-free nitrogen (OFN).
- c) Evacuate (optional for R454C).
- d) Purge the circuit with oxygen-free nitrogen (OFN) (optional for R454C).
- e) Open the circuit by cutting or brazing.

The refrigerant shall be recovered into the correct recovery cylinders.

Due to use of flammable refrigerants, the system shall be purged with oxygen-free nitrogen to render the appliance safe for flammable refrigerants. This process might need to be repeated several times.

- Compressed air or oxygen shall not be used for purging flammable refrigerant systems.

For appliances containing flammable refrigerants, refrigerants purging shall be achieved by breaking the vacuum in the system with oxygen-free nitrogen and continuing to fill until the working pressure is achieved, then venting to atmosphere, and finally pulling down to a vacuum (optional for R454C). This process shall be repeated until no refrigerant is within the system (optional for R454C). When the final oxygen-free nitrogen charge is used, the system shall be vented down to atmospheric pressure to enable work to take place.

Ensure that the outlet for the vacuum pump is not close to any potential ignition sources and that ventilation is available.

### **Charging procedures:**

In addition to conventional charging procedures, the following requirements shall be followed.

- Ensure that contamination of different refrigerants does not occur when using charging equipment.
- Hoses or lines shall be as short as possible to minimize the amount of refrigerant contained in them.
- Cylinders should be kept in an appropriate position according to the instructions.
- Ensure that the REFRIGERATING SYSTEM is earthed prior to charging the system with refrigerant.
- Label the system when charging is complete (if not already).
- Extreme care shall be taken not to overfill the REFRIGERATING SYSTEM.

Prior to recharging the system, it shall be pressure-tested with the appropriate purging gas. The system shall be leak-tested on completion of charging but prior to commissioning. A follow up leak test shall be carried out prior to leaving the site.

### **Decommissioning:**

Before carrying out this procedure, it is essential that the technician is completely familiar with the equipment and all its details. It is recommended good practice that all refrigerants are recovered safely. Prior to the task being carried out, an oil and refrigerant sample shall be taken in case analysis is required prior to re-use of recovered refrigerant. It is essential that electrical power is available before the task commences.

- a) Become familiar with the equipment and its operation.
- b) Isolate the system electrically.
- c) Before attempting the procedure, ensure that:
  - I. Mechanical handling equipment is available, if required, for handling refrigerant cylinders.
  - II. All personal protective equipment is available and is being used correctly.
  - III. The recovery process is supervised at all times by a competent person.
  - IV. Recovery equipment and cylinders conform to the appropriate standards.
- d) Pump down the refrigerant system, if possible.
- e) If a vacuum is not possible, make a manifold so that refrigerant can be removed from various parts of the system.
- f) Make sure that the cylinder is situated on the scales before recovery takes place.
- g) Start the recovery machine and operate in accordance with instructions.
- h) Do not overfill cylinders (no more than 80% volume liquid charge).
- i) Do not exceed the maximum working pressure of the cylinder, even temporarily.
- j) When the cylinders have been filled correctly and the process completed, make sure that the cylinders and the equipment are removed from the site properly and all isolation valves on the equipment are closed off.
- k) Recovered refrigerant shall not be charged into another refrigerating system unless it has been cleaned and checked.

**Labeling:**

Equipment shall be labeled stating that it has been de-commissioned and emptied of refrigerant. The label shall be dated and signed. For appliances containing flammable refrigerants, ensure that there are labels on the equipment stating the equipment contains flammable refrigerant.

**Recovery:**

When removing the refrigerant from a system, either for servicing or decommissioning, it is recommended good practice that all refrigerants are removed safely.

When transferring refrigerant into cylinders, ensure that only appropriate refrigerant recovery cylinders are employed. Ensure that the correct number of cylinders for holding the total system charge is available. All cylinders to be used are designated for the recovered refrigerant and labeled for that refrigerant (i.e., special cylinders for the recovery of refrigerant). Cylinders shall be complete with pressure-relief valve and associated shut-off valve in good working order. Empty recovery cylinders are evacuated and, if possible, cooled before recovery occurs.

The recovery equipment shall be in good working order with a set of instructions concerning the equipment that is at hand and shall be suitable for the recovery of all appropriate refrigerants including, when applicable, FLAMMABLE REFRIGERANTS. In addition, a set of calibrated weighing scales shall be available and in good working order. Hoses shall be complete with leak-free disconnect coupling and in good condition. Before using the recovery machine, check that it is in satisfactory working order, has been properly maintained and that any associated electrical components are sealed to prevent ignition in the event of refrigerant release. Consult manufacturer if in doubt.

The recovered refrigerant shall be returned to the refrigerant supplier in the correct recovery cylinder, and the relevant waste transfer note arranged. Do not mix refrigerants in recovery units and especially not in cylinders.

If compressors or compressor oils are to be removed, ensure that they have been evacuated to an acceptable level to make certain that FLAMMABLE REFRIGERANT does not remain within the lubricant. The evacuation process shall be carried out prior to returning the compressor to the suppliers. Only electric heating to the compressor body shall be employed to accelerate this process. When oil is drained from a system, it shall be carried out safely.

## D) BASE COMPONENT LAYOUT

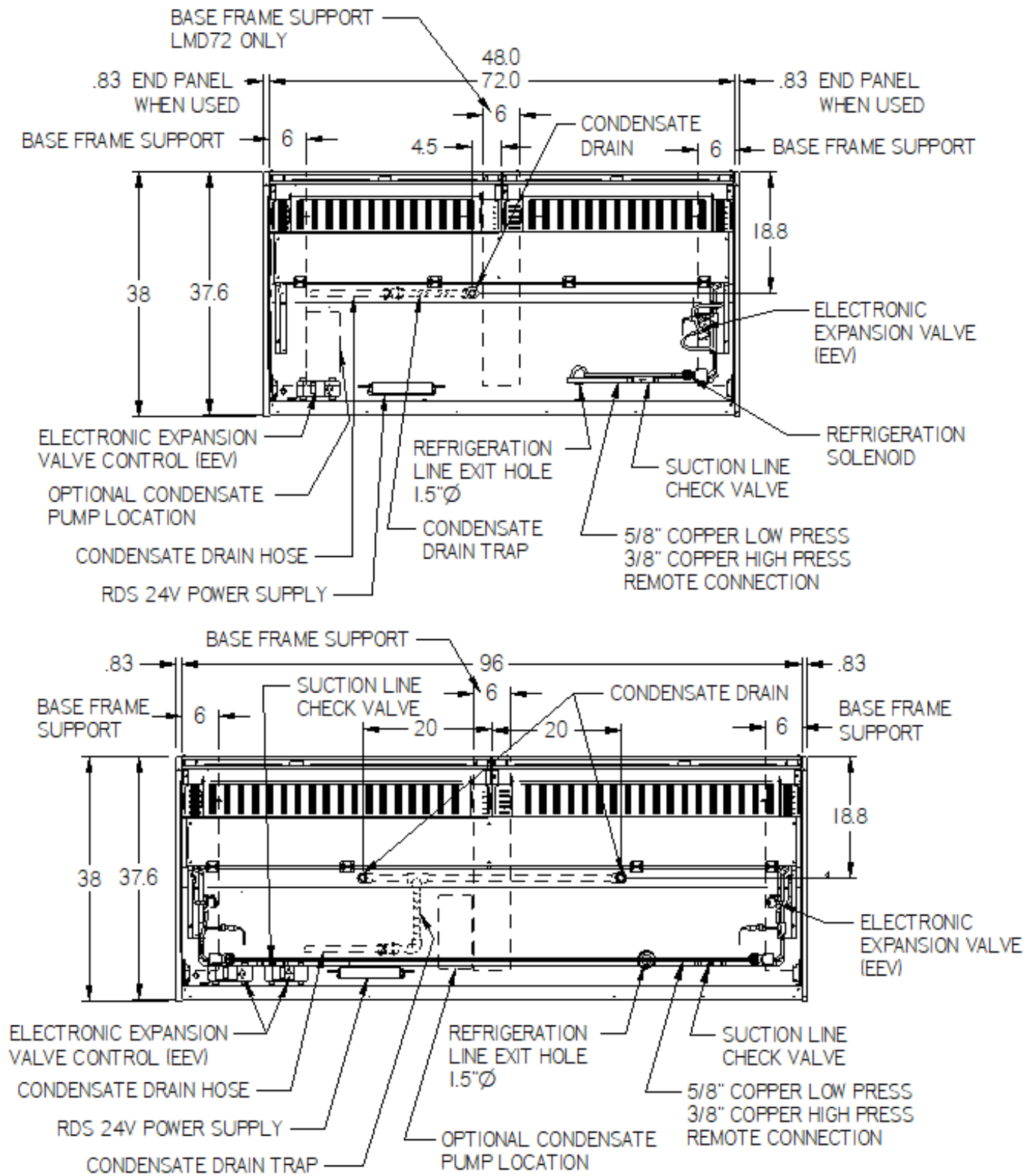

---

---

## E) ELECTRICAL & REFRIGERATION DATA

---

---

MODELS	LMD4878R	LMD7278R	LMD9678R
REFRIGERANT	R454c		
VOLTS	120 VOLTS		
FREQUENCY	60 HERTZ		
PHASE	1 PHASE		
# OF WIRES	2 WIRE + GROUND		
TOTAL AMPS	4 AMPS	4 AMPS	4 AMPS
OPTIONAL CONENSATE PUMP	(1)1.5 AMPS 120 VOLTS		

**Refer to the rating plate data attached to side of base for Maximum Fuse Size and Minimum Circuit Ampacity.**

---

---

## F) INSTALLATION

---

---

**IMPORTANT:** Read this Section of this manual located on page 7&8.

“REFRIGERATION WARNING &INSTALLATION-REPAIR-DECOMMISSIONING”

All refrigeration and electrical work must be performed by certified technicians.

The installation of the appliance and the refrigerant must only be performed by Federals approved Service or suitably qualified person.

Appliance to be installed in accordance with safety standards ANSI/ASHREA 15.

Case meets requirements for safe operation in climate class 3 environment. (Dry bulb temperature, 77°F; Relative humidity 60%). This is not a performance indication.

This case is designed for performance in NSF TYPE 2 environment: Maximum Ambient Temperature cannot exceed 80°F and Maximum Relative Humidity of 55%.

## **INSPECTION FOR SHIPPING DAMAGE**

You are responsible for filing all freight claims with the delivering truck line. Inspect all cartons and crates for damage as soon as they arrive. If damage is noted to shipping crates, cartons, or if a shortage is found, note this on the bill of lading (all copies) prior to signing.

If damage is discovered when the case is uncrated, immediately call the delivering truck line and follow-up the call with a written report indicating concealed damage to your shipment. Ask for an immediate inspection of your concealed damaged item. Crating material must be retained to show the inspector from the truck line.

## **LOCATING THE DISPLAY CASE**

The case(s) should be located where it is not subjected to the direct rays of the sun, heating ducts, grills, radiator, or ceiling fans, nor should it be located near open doors or main door entrances. Also, avoid locations where there is excessive air movement or air disturbances and avoid high humidity locations such as near cases with water misting or fogging devices. Failure to locate this case as stated will reduce the performance of your display and will affect temperature of interior of case and product.

If this case or cases are to be located against a wall there should be at least 6” between the case and the wall to allow air circulation. Failure to give adequate space may cause exterior surfaces to sweat.

## **REMOTE UNITS**

There are special requirements for A2L refrigerants such as R454C

Piping material, pipe routing, and installation shall include protection from physical damage in operation and service, and be in compliance with national and local codes and standards, such as ANSI/ASHRAE 15, IAPMO Uniform Mechanical Code, ICC International Mechanical Code, or CSA B52. All field joints shall be accessible for inspection prior to being covered or enclosed

The installation of pipe work shall be kept to a minimum.

Federal remote units are charged with dry nitrogen only. Joints made in the installation where any part is pre-charged shall be made in accordance with the following:

- a) A brazed, welded or mechanical connection shall be made before opening the valves to permit refrigerant to flow between the refrigerating system parts. A vacuum valve shall be provided to evacuate the interconnecting pipe and/or any uncharged refrigerating system part.
- b) Mechanical connectors used indoors shall comply with ISO14903 or UL 207 or CSA C22.2 No.140.3. When mechanical connectors are reused indoors, sealing parts shall be renewed. When flared joints are reused indoors, the flare part shall be refabricated.

- c) Refrigerant tubing shall be protected or enclosed to avoid damage. Flexible refrigerant connectors (such as connecting lines between the indoor and outdoor unit) that might be displaced during normal operation shall be protected against mechanical damage.

Mechanical connections shall be accessible for maintenance purposes.

Provisions shall be made for expansion and contraction of long runs of pipes. Protection devices, piping, and fittings shall be protected as far as possible against adverse environmental effects, for example, the danger of water collecting and freezing in relief pipes or the accumulation of dirt and debris.

Piping in refrigeration systems shall be designed and installed to minimize the likelihood of hydraulic shock damaging the system

Do not use steel refrigeration lines with Federal products.

Flexible pipe elements shall be protected against mechanical damage, excessive stress by torsion, or other forces, and that they should be checked for mechanical damage annually.

Precautions shall be taken to avoid excessive vibration or pulsation. Use vibration dampening tubing clamps as necessary, especially near sources of vibration.

This unit requires a minimum room area size to operate in. See table below for minimum room areas

<b>Model</b>	<b>A<sub>min</sub> [sq meters]</b>	<b>A<sub>lim</sub> [sq ft]</b>
LMD4878	19	200
LMD7278	22	240
LMD9678	14	150

After completion of field piping for split systems, the field pipework shall be pressure tested with dry nitrogen and then vacuum tested prior to refrigerant charging according to the following requirements:

- 1) The minimum test pressure for the low side of the system shall be the low side design pressure and the minimum test pressure for the high side of the system shall be the high side design pressure, unless the high side of the system cannot be isolated from the low side of the system in which case the entire system shall be pressure tested to the low side design pressure. See the unit data plate for applicable pressures.
- 2) The test pressure after removal of pressure source shall be maintained for at least 1 h with no decrease of pressure indicated by the test gauge, with test gauge resolution not exceeding 5 % of the test pressure.

3) During the evacuation test, after achieving a vacuum level of 250 microns or less, the refrigeration system shall be isolated from the vacuum pump, and the pressure shall not rise above 500 microns within 10 min. The vacuum pressure level shall be the lessor of 500 microns or the value required for compliance with national and local codes and standards, which may vary between residential, commercial, and industrial buildings.

Always follow local codes during installation.

Be sure that any refrigeration line running through an occupied space is protected against damage by using line set covers, sleeving, etc. As little line set as possible should be run through an occupied space. Run refrigeration line sets through building floors, ceilings, walls, or mechanical rooms as much as possible. Be sure to follow all local codes.

**Maximum Releasable Charge**

The maximum releasable charge may be required to comply with local codes. This must be calculated for the complete system as follows:

$$M_{rel} = \text{Maximum Releasable Charge}$$

$$M_{rel} \text{ of Federal Product} + M_{rel} \text{ of condensing unit} + M_{rel} \text{ of line set}$$

The table below shows various maximum releasable charge values for line sets.

		Liquid Line Maximum Releasable Line Charge By Length							
		1/4" (6.35mm)		3/8" (9.53mm)		1/2" (12.7mm)		3/4" (19.1mm)	
Line Length [ft]	Line Length [m]	lbs	kg	lbs	kg	lbs	kg	lbs	kg
10	3.0	0.6	0.3	0.8	0.4	1.1	0.5	0.6	0.3
50	15.2	1.1	0.5	2.1	1.0	3.5	1.6	1.1	0.5
100	30.5	1.8	0.8	3.8	1.7	6.5	3.0	1.8	0.8
250	76.2	3.8	1.7	8.8	4.0	15.6	7.1	3.8	1.7

		Suction Line Maximum Releasable Line Charge By Length							
		1/2" (12.7mm)		5/8" (15.9mm)		3/4" (19.1mm)		7/8" (22.2mm)	
Line Length [ft]	Line Length [m]	lbs	kg	lbs	kg	lbs	kg	lbs	kg
10	3.0	1.0	0.4	1.3	0.6	1.7	0.8	2.2	1.0
50	15.2	3.1	1.4	4.8	2.2	6.8	3.1	9.2	4.2
100	30.5	5.8	2.6	9.2	4.2	13.2	6.0	17.9	8.1
250	76.2	13.9	6.3	22.3	10.1	32.4	14.7	44.1	20.1

## **REMOVING CASE FROM SHIPPING SKID**

Remove the (8) 1/4" screws that secure the case to the skid. These screws are located in the front and rear Base Rails. The (4) screws in the rear base rail are easily accessible from the back of the case. To access the (4) screws in the front base rail the Front Kick panel will need to be removed.

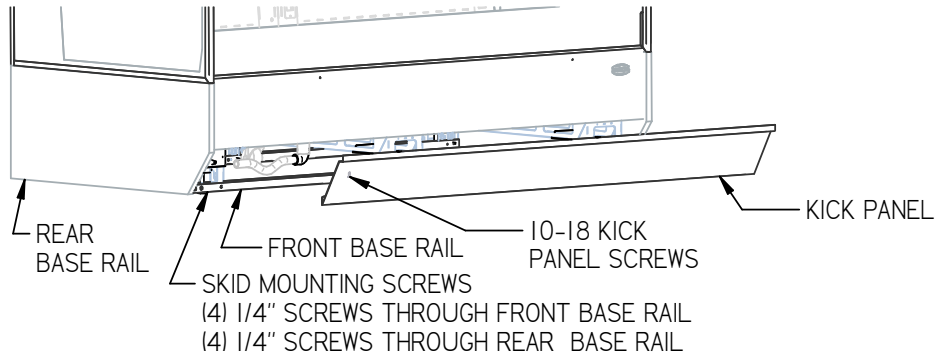

Note that the case has casters installed at factory to allow case to be moved to final location. There are leg levelers on bottom of case, once case is off skid turn the leg levelers up to allow case to roll on casters.

## **REMOVING PACKAGING MATERIAL**

Remove bubble wrap and packing material for all shelves and panel, brackets, etc. If it is necessary to remove tape residue from plastic materials, use cleaning compounds recommended in the cleaning section of this manual.

## LIFTING AND MOVING CASE



**CAUTION:** Do not push or pull against the clear acrylic deflector on front of case. Doing so can cause the acrylic to break and may cause injury.

Do not push or pull on side glass or pull on base panel. Doing so will break glass or pull out panel mounting screws.

Care must be taken not to damage or tip the case when removing it from the skid or moving the case.

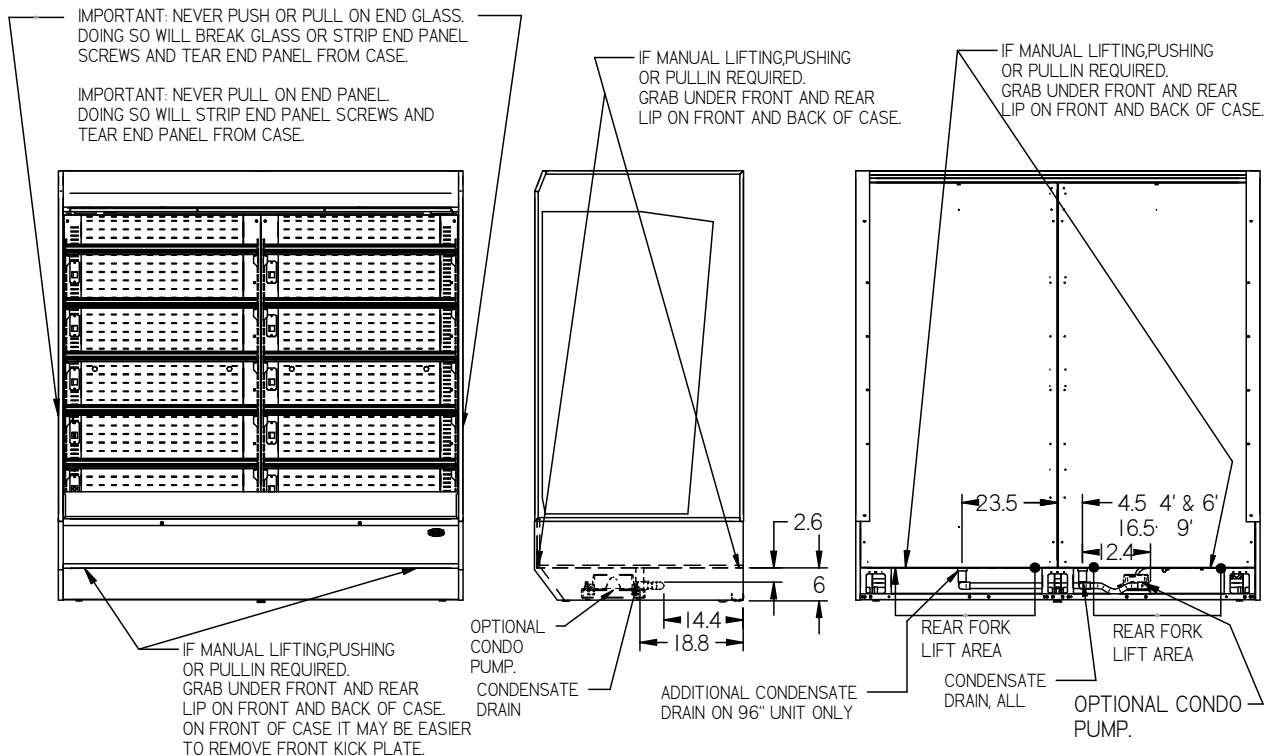

- Care must be taken when lifting and moving cases from skid as well as moving case into position.

- The case should be lifted off skid using a fork lift. The case must be lifted from rear in location noted in picture above. Be sure case is balanced equally on forks. When sliding forks under case someone must be watching that forks do not hit and damage refrigeration lines, drain or optional condensate pump.

-To prevent injury, it is not recommended to attempt lifting case manually. When lifting, pulling or pushing is required grab under front and back lip of case.

-Case is supplied with casters and once case is off of skid and on floor it should move easily into position. Light pushing on lower part of end near the base is fine. NEVER PUSH OR PULL ON GLASS. DOING SO CAN BREAK GLASS. NEVER PULL ON END PANEL OR GLASS. Doing so will strip end panel screws and tear end from case.

## **SINGLE CASE INSTALLATION**

### **Leveling the Case**

It is important that the cases are level. This will allow for proper drainage of condensate water from evaporator coil. Once the case is rolled to final location the case must be level for proper drainage of defrost water to the condensate pump. A wrench is included to aid in adjusting leg levelers

Check the level of the case along front of acrylic air deflector.

Adjust the (4) outside leg levelers as needed to **level** the case in each direction.

The LMD72 & LMD96 have (2) center leg levelers adjust these so that the center of base floor is flat.

**NOTE:** If necessary use a wood or plastic shim under each leg leveler to avoid scratching the tile floor.

### **Sealing Unit to The Floor**

After the unit is positioned and the leg levelers are turned out, the unit needs to be sealed to the floor for NSF approved installation.

# MULTIPLE CASE LINEUP INSTALLATION

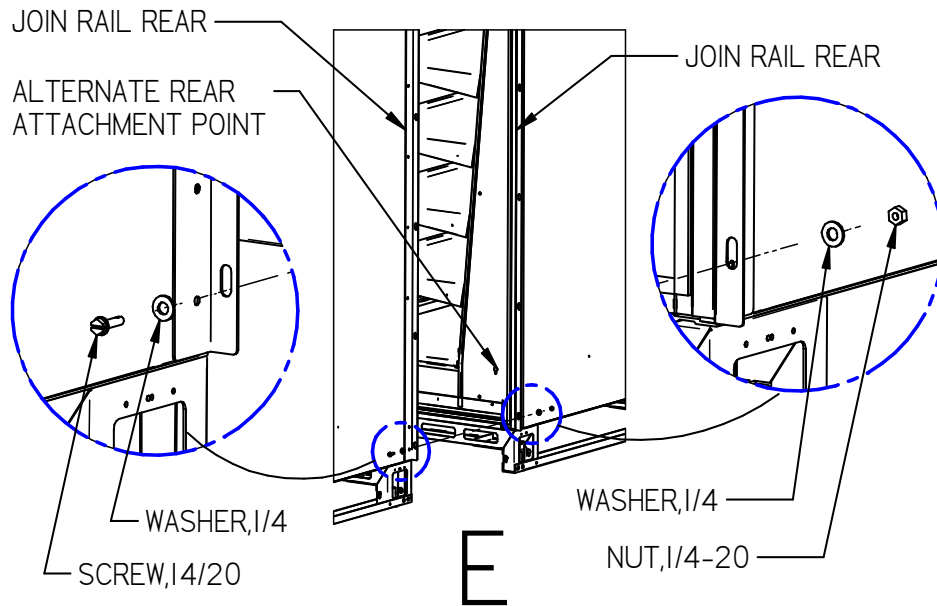
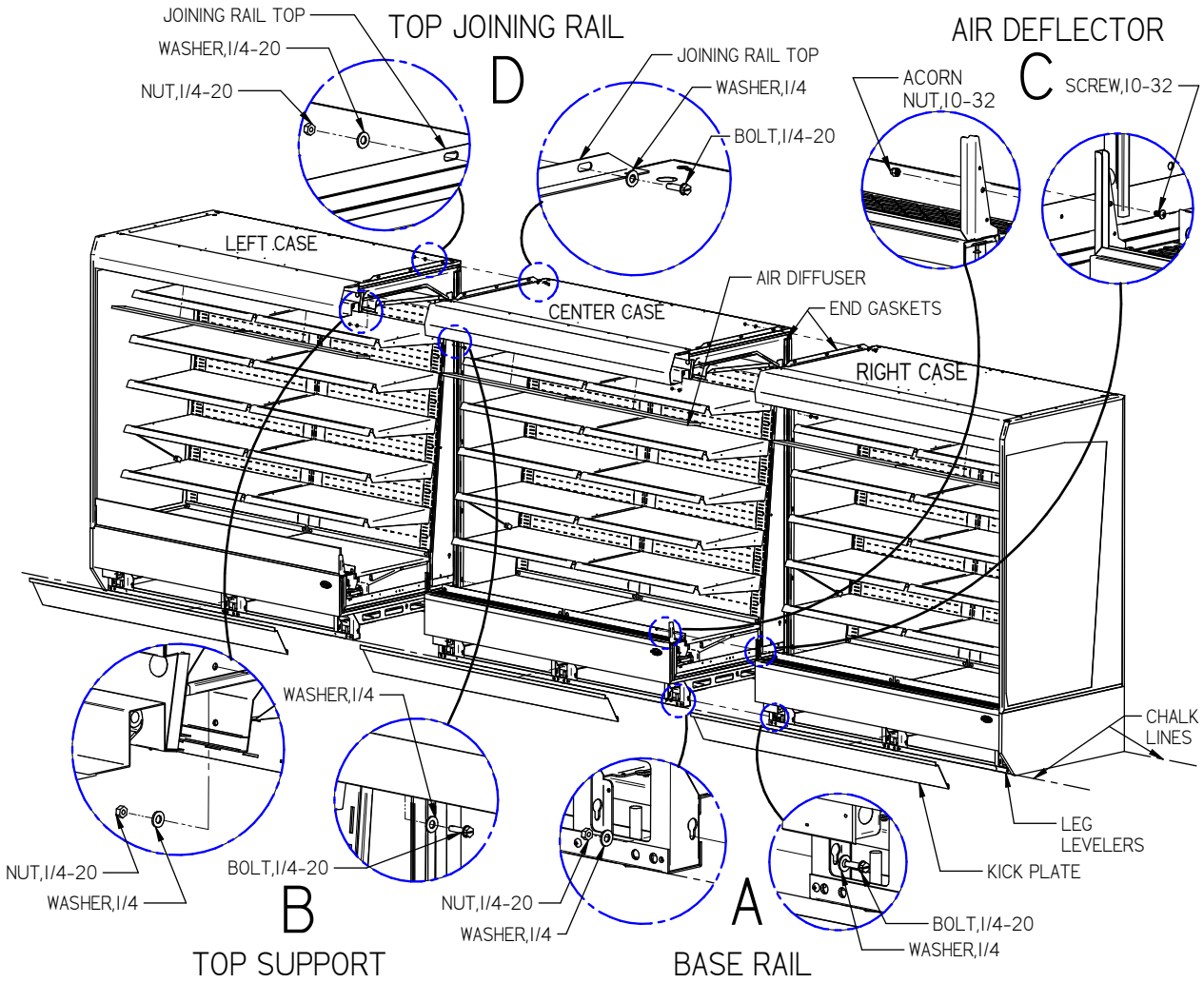

## Two Cases Connected to Single Remote Condenser

If (2) cases are ordered from factory to run on a single condensing unit, there is only one control that will operate both units.

The cases are prewired to connect both refrigeration solenoids together. These Wires are hanging out from joining side of each case near the top front behind canopy.

Once all prep work is complete and both cases are ready to be joined, connect the wires from each case together. Connect the yellow wire from case 1 to yellow wire to from case 2 and connect the white wire from case 1 to white wire from case 2.

Once connected join cases as described below. Be careful not to pinch the wires between cases.



**CAUTION:** The refrigeration solenoid on the case that does not have a control is powered from the case that does have the control. When servicing cases disconnect power from both cases to prevent electrical shock.



**⚠ DANGER**  
HIGH VOLTAGE.  
Turn power off  
before servicing.  
May have more than  
one disconnect  
switch.

"IMPORTANT"  
BEFORE INSTALLING CASES TOGETHER  
CONNECT YELLOW WIRE FROM CASE 1  
TO YELLOW WIRE FROM CASE 2.  
CONNECT WHITE WIRE FROM CASE 1  
TO WHITE WIRE FROM CASE 2.  
WHEN PLACING CASES TOGETHER DO  
NOT PINCH WIRES BETWEEN CASES.

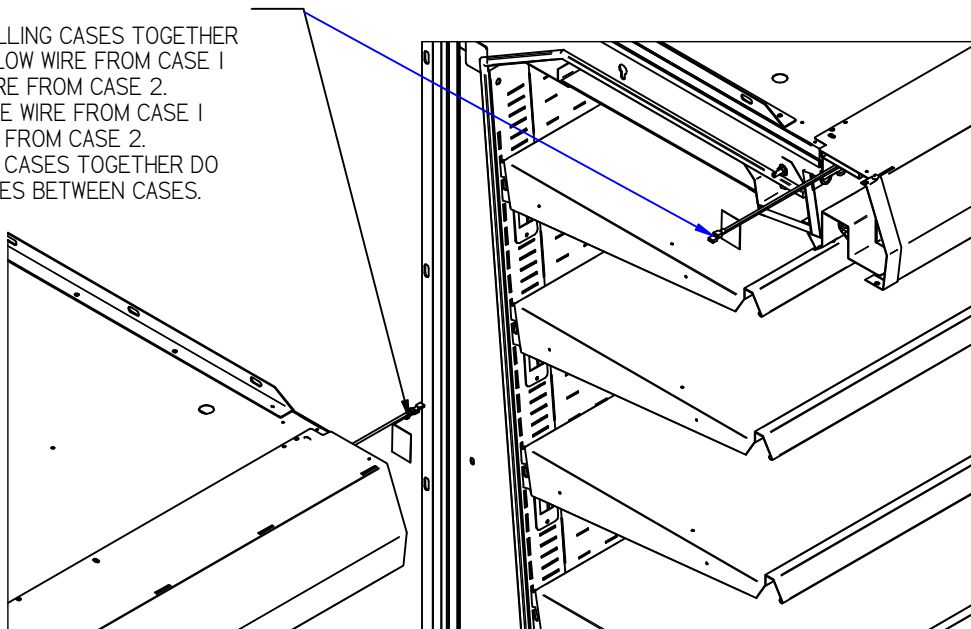

## **Floor Preparation**

Be sure the floor where the case line up will be located is strong enough to support cases without sagging.

It is important that the cases are level. This will allow for proper drainage of condensate water from evaporator coil and allow for proper alignment of cases.

Most floors are not level and the high and low spots in location of cases must be determined. Place a chalk line in the desired position of where the back of the cases will be located. If the back of the cases are to be along a wall there should be at least 6" clearance between wall and the back of the cases.

Measure 33.25" from this chalk line to where the front of cases will be. This line is where the front base rail meets the floor not the actual front of the case.

Mark the location along these lines that the outside edges of case will be. The cases without end panels will be 48", 72", or 96" depending on cases ordered. Add additional 1" to case end that has an end panel.

Use a transit or line level to determine the highest point along chalk line.

## **Joining and Leveling Line Up**

If case line up is along a wall it will make it difficult to gain access to back of case once line up is complete. If it all possible make all connections accessible from front under side of cases, but if necessary make any required connections at back of case as you install the cases.

-There are factory installed gaskets located on each end of all adjoining cases. Inspect all gaskets to be sure they are properly located and not damaged.

-Remove the front kick plates from all cases as described Panel Removal section of this manual.

-Remove all Top Air Diffuser from all cases from upper air duct track. Loosen thumb screws on Retainers located behind air diffuser. Retainer will drop down allowing diffuser to be pulled out of case.

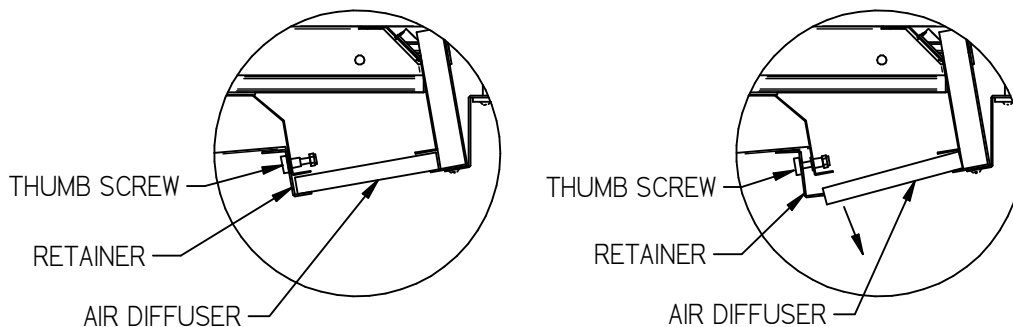

-The required fasteners to join cases are installed at the factory in the location they will be used. These fasteners are on the left side of each case. As each case is installed remove these fasteners from the case and reuse them.

-Determining highest point as described in Floor Preparation above. Install the case that will be located over the highest point first. Once the first case is rolled to final location the case must be level for proper drainage of defrost water to the condensate pump. A wrench is included to aid in adjusting the leg levelers. Check the level of the case along the ledge in front of acrylic air deflector. Adjust the (4) outside leg levelers as needed to level the case in each direction. The LMD72 & LMD96 have (2) center leg levelers adjust these so that the center of base floor is flat. If necessary, use a wood or plastic shim under each leg leveler to avoid scratching the tile floor

-Place the next adjoining case into line up. Level case until case end profiles are aligned and touching. Install fasteners in the order below as designated with corresponding letter in detailed diagram. As cases are joined additional leg leveler adjustments may be necessary.

- A)** Align the front of the base rail and fasten through hole in base rail using ¼-20 bolt and ¼-20 nut, use a ¼ washer against each base support as shown in diagram.
- B)** Align the top front of case and fasten through hole in top support using ¼-20 bolt and ¼-20 nut, use a ¼ washer against each top support as shown in diagram. If necessary the top valance can be adjusted to provide better alignment. Loosen the fasteners along the top of the valance located on top of case and adjust as needed. If a perfect alignment cannot be achieved Valance Joining strap can be used only if needed. Place strap over seam and attach with self-drilling screws provided.

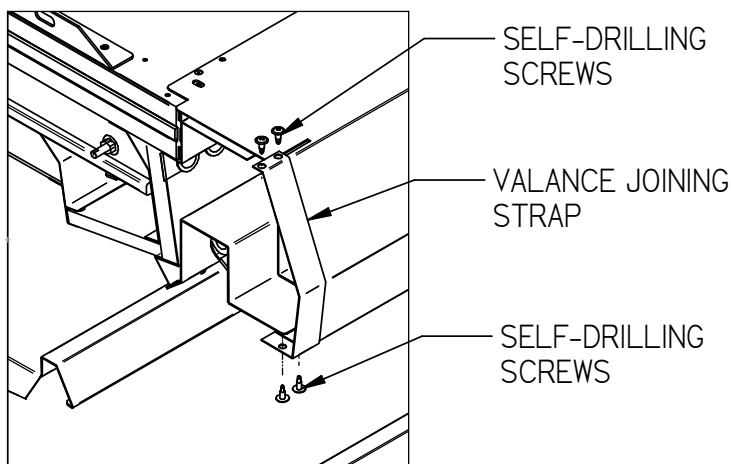

- C)** Align the holes in the air deflector supports and join with 10-32 screw and 10/32 acorn nut.
- D)** Align slots in top joining rail and join using ¼-20 bolt and ¼-20 nut, use a ¼ washer against each top joining rail as shown in diagram.
- E)** Align slots in rear joining rail and join using ¼-20 bolt and ¼-20 nut, use a ¼ washer against each rear joining rail as shown in diagram. Alternate rear attachment point shown in diagram is used if it is not possible to get to back of case. Using this attachment point requires removing all shelving and slotted back panel from both cases to gain access. See appropriate section of this manual for shelf and slotted back panel removal.

Repeat for all additional cases in line up. Once all cases are attached continue with electrical, refrigeration and drain connections as described in appropriate section of this manual. Reinstall Kick Panels and air diffusers as described in appropriate section of this manual.

### **Sealing all Unit to The Floor**

After the unit is positioned and the leg levelers are turned out, the unit needs to be sealed to the floor for NSF approved installation.

### **ELECTRICAL CONNECTION**



**DANGER: Improper or faulty hookup of electrical components in the display case can result in severe injury or death.**

#### **Permanent Connected (Standard)**

- Only a licensed electrician must perform all case electrical connections.
- All electrical wiring hookups must be done in accordance with all applicable local, regional, or national electrical standards.
- A separate circuit for each display case is required to prevent other appliances on the same circuit from overloading the circuit and causing malfunction.
- The Merchandiser unit and the condensing unit do not share any wiring.
- The electrical service must be grounded upon installation.
- See the electrical data plate located on the inside back wall of display case, for proper circuit size and wire ampacity.

**Standard Bottom Base Electrical Connection:** Use this electrical connection when power source is from floor or wall outlet. The electrical connection box is on the bottom left side of case behind the bottom Front Kick Panel. The box is accessible by removing the Front Kick Panel. (See “Panel Removal Section” of this manual for panel removal instructions). Remove electrical box cover to access electrical connection.

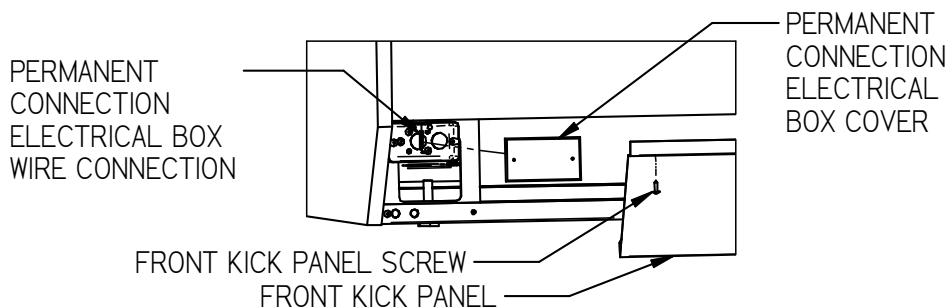

**Top Electrical Connection (OPTION):** Use this optional factory installed electrical connection when power source is from the ceiling. If equipped with this option the connection box is located on the top back left corner of case. Remove electrical box cover to access electrical connection.

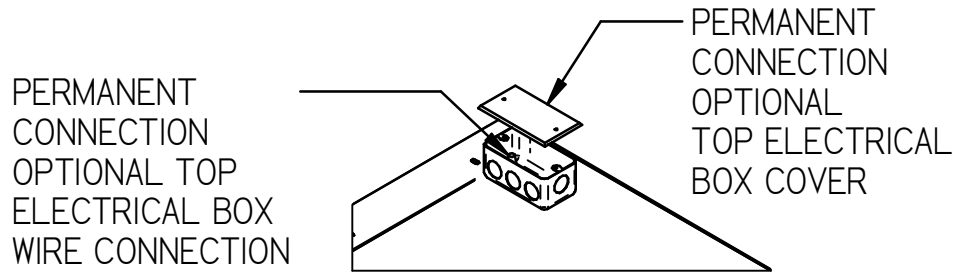

## PANEL REMOVAL FOR ELECTRICAL ACCESS



**DANGER: Electric shock hazard. Do not operate unit with panels removed.**

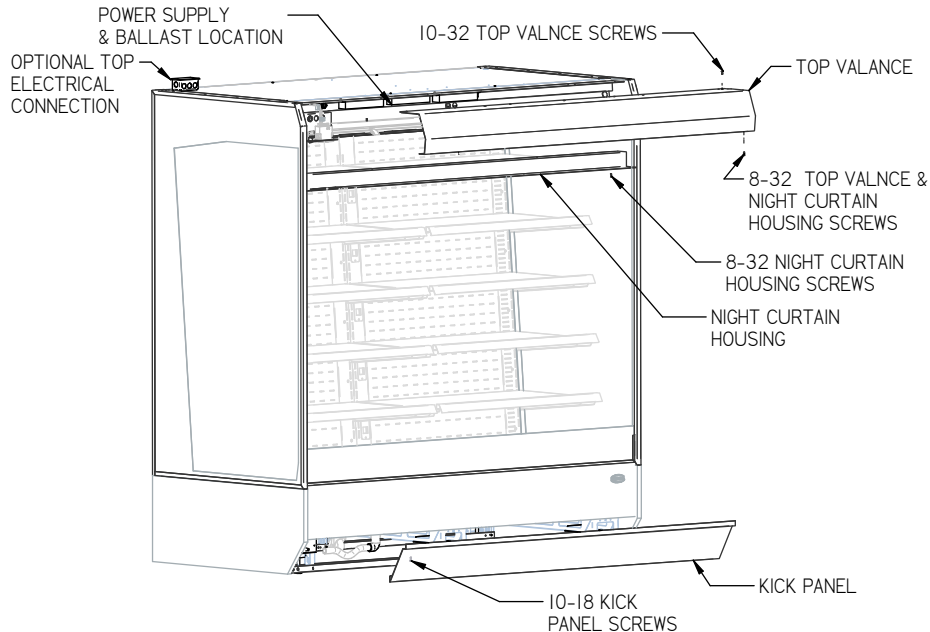

### Kick Panels

The kick panel located at the front base of unit can be removed to access electrical connection, condensate drain trap and hose, leg levelers and casters.

1. Loosen the 3 to 5 10-18 Kick Panel screws located under the front lip of Kick Panel.
2. Tilt the top of the Kick Panel away from the base. The bottom of Kick panel is setting on top of a frame rail and once screws are removed the Kick Panel will drop down and out of case
3. Set the Kick Panel and screws in safe place to prevent damage.
4. Reinstall Kick Panel in the reverse order.

### Front Valance & Night Curtain Housing Removal

The Front Valance can be removed to access all lighting ballasts, power supplies and controls. If additional access is required, the Night Curtain Housing can also be removed. The Night Curtain Housing is located directly behind the top front valance. The night curtains are housed inside

1. Remove the front (3) to (5) 8-32 screws holding the Night Curtain to the Front Valance.
2. From top of case remove the (3) to (5) 8-32 screws holding the Front Valance to top of case.
3. Carefully remove Front Valance from unit and set Front Valance and screws in safe place to prevent damage.
4. If additional access is required remove the Night Curtain Housing.  
Hold up on Night Curtain Housing and Remove the back (3) to (5) 8-32 Night Curtain Housing screws.
5. Set the Night Curtain Housing and screws in safe place to prevent damage.
6. Reinstall Front Valance and Night Curtain Housing in the reverse order.

### **CONDENSATE DRAIN HOSE (STANDARD)**

The case is furnished with a drain trap & 25' of drain hose. The drain hose must be run to a nearby floor drain. If draining up a slope or into a drain that is not on floor an optional pump must be used.

The drain hose is rolled up under the case for shipment. It can be accessed from the back of case and run to nearby floor drain. The drain trap and drain hose can also be accessed from front of case by removing the front Kick Panel. (See panel removal section of this manual)

Be sure not to kink or pinch hose when running drain line to floor drain.

### **CONDENSATE PUMP (OPTIONAL)**

**NOTICE: This unit could be shipped with an optional condensate pump. The pump has a float that turns the pump on automatically when needed.**

**The pump is mounted in the base compartment. The pump should be cleaned and inspected every 3-4 months.**

**Note: There is a piece of cardboard that has to be removed from the side of the pump to free up the float. If this is not done, the pump will not turn on and the pan will overflow.**

The case is available with an optional condensate pump. The pump is located under the case and wired to the display case electrical. It is also furnished with a drain trap & 25' of drain hose. The drain hose must be run to a drain. The pump can be accessed by removing the Kick Panel as described in the Panel Removal section of this manual.

The drain hose is rolled up under the case for shipment. It can be accessed from the back of case and run to nearby floor drain. The drain trap and drain hose can also be accessed from front of case by removing the front Kick Panel. (See panel removal section of this manual)

Be sure not to kink or pinch hose when running drain line to floor drain.

## SHELVING INSTALLATION

The LMD has 5 tiers of solid metal shelves. LMD48 Models have a total of 5 shelves and the LMD72 and LMD96 shelves are split in the middle with a total of 10 shelves. Standard Shelves for each case are the same so any shelf will fit in any tier location. Some cases may be provided with optional staggered shelves meaning each shelf is a different depth. If case has optional staggered shelves the deepest shelf goes on the bottom and shallowest goes on the top.

Cases are shipped with shelves installed in the flat straight position and with the top of the bottom shelf 10.5" from top of the deck. The remaining shelves would be spaced 9.7" apart. This is a good starting shelf location and then shelf can be adjusted to suit product needs.

Follow the instruction in the illustration below. Start with the bottom shelf and determine desired shelf location. The shelves are adjustable in 1 5/8" increments and can be set in either a flat straight position or in a 10deg tilt position.

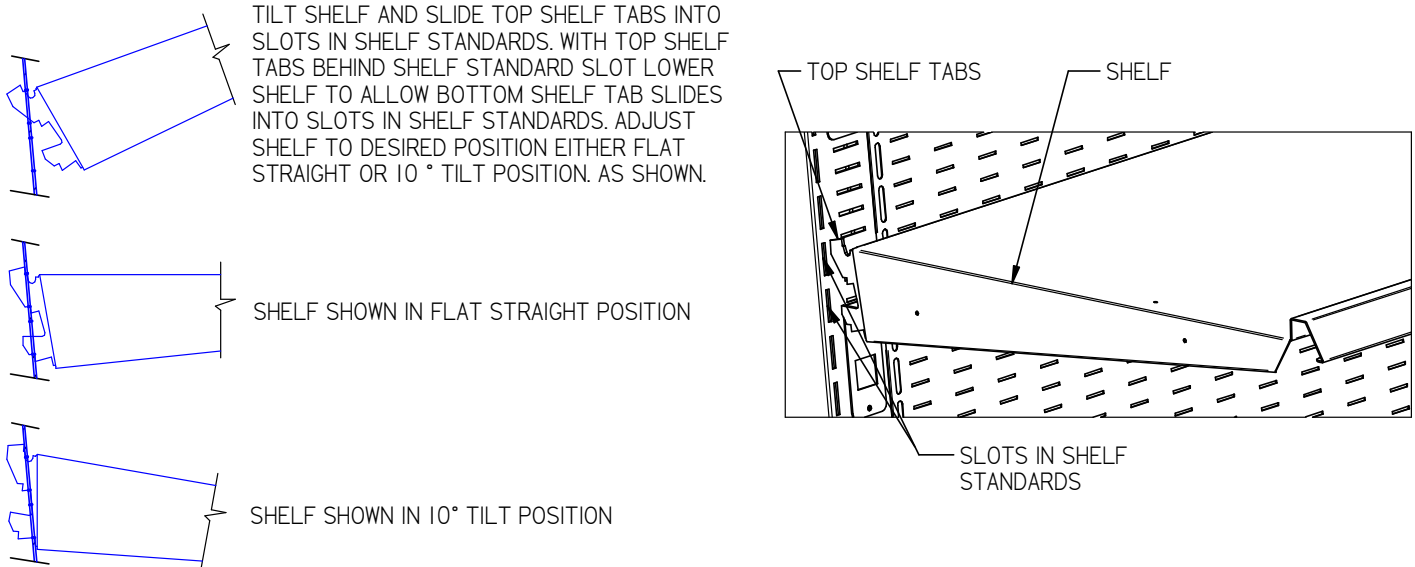

## **SHELF LIGHTS**

1. The shelf lights are attached with tape to the front underside of each shelf as shown below.  
Place LED Light Strip under shelf as shown and center it on shelf. The LED Light Strip plug end must be to the left side of the case.
2. Attach the Shelf Light Cord to the end of the LED light Strip as shown.

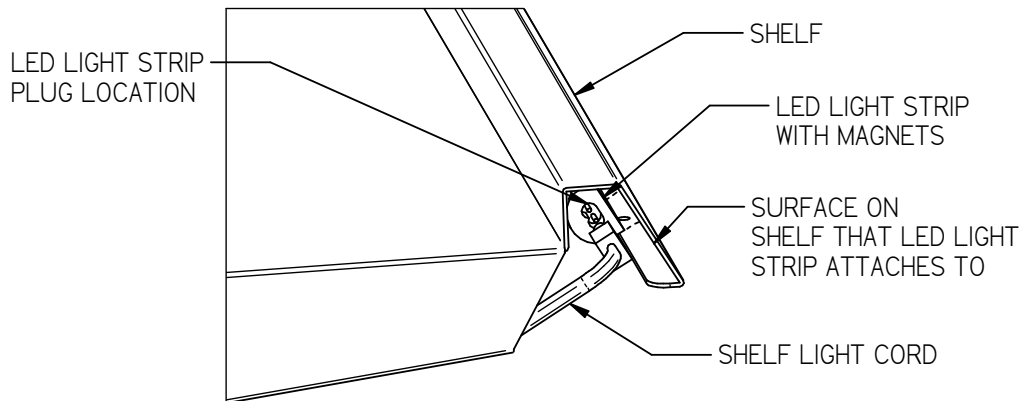

3. Remove the cap from the appropriate female light sockets.  
If the socket is not being used for a shelf light, the cap must be plugged into socket to prevent contamination and moisture out of the socket.
4. Plug in each shelf light by aligning the male pins on the appropriate shelf light cord plugs with the female light sockets and push together. **IMPORTANT:** Do not roll plug during insertion.
5. Hook extra cord in notch on end of shelf support and notch on back flange of shelf to keep it out of the way as shown.



---

---

## G) OPERATING INSTRUCTIONS

---

---



### **CONTROL DESCRIPTION**

#### **Light Switch**

The unit has a light switch that turns on and off the interior lights of unit.

#### **Electronic Temperature Control**

Located in the rear grille of the display case, the temperature control allows the user to adjust the temperature of the display merchandiser to their needs.

## **ELECTRONIC TEMPERATURE CONTROL OPERATION**

This unit is equipped with an electronic temperature control. The control parameters are set at the factory and cannot be manually changed in the field. The preset control parameters are listed on the chart in the Settings Chart below.

### **Operation**

The control uses two sensors, one located in the air stream and one located on the evaporator coil. The sensor located in the air stream is referred to as the temperature control sensor. The sensor located on the evaporator coil is referred to as the defrost probe. The temperature control sensor is located on the plastic tub behind the evaporator coil to the left in the cold air stream. The sensor location is critical for proper operation on the unit. Do not move or relocate this sensor.

The coil sensor is strapped to the evaporator coil. This sensor location is critical for proper operation of the unit. Do not move or relocate this sensor. The temperature control is set to cut in at 39°F (3.9°C). The Temp control cuts out at 26°F (-3.3°C) at the coldest setting “9” and 36°F (2.2°C) at the warmest setting “1”.

### **Defrost Cycle**

The control is programmed to initiate defrost via two different methods. There are 3 programmed defrost cycles in the case which will initiate a defrost cycle every 8 hours. The unit does not have a time clock so the defrost cycles cannot be set for any specific time of day.

The unit also has an ‘On demand’ defrost feature that will initiate a defrost when the temperature differential between the evaporator temperature and the air temperature is more than 20°F (11.1°C) for 5 minutes after 30 minutes into the refrigeration cycle (e.g. if the air stream probe measures 42°F/5.6°C or greater and the defrost probe measures 20°F/-6.7°C or lower for five minutes). Once initiated the defrost cycle will terminate when evaporator coil sensor reaches 43°F (6.1°C).

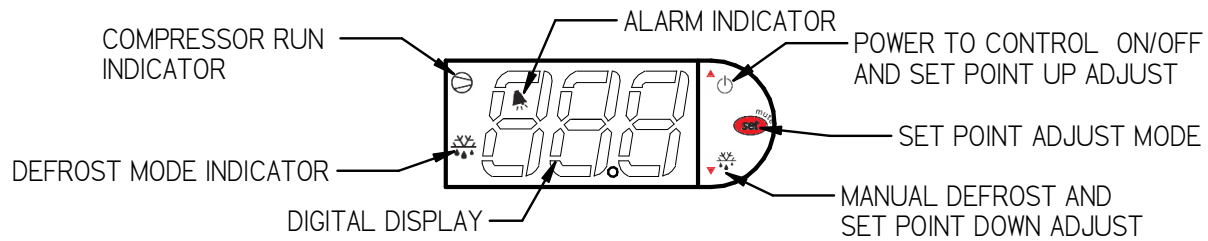

If a manual defrost is required, one can be initiated by pressing and holding the down arrow for three (3) seconds. This is typically unnecessary and should only be performed if special circumstances require it.





### Button Overview

	Press and hold this button for 3 seconds to turn system on (if off) or off (if on). Also used to adjust set point when in set point adjust mode
	Press to enter set point adjust mode, confirm set point changes, and mute alarms.
	Press and hold this button for 3 seconds to initiate a manual defrost (and cancel defrost if initiated), also adjusts set point down when in set point adjust mode



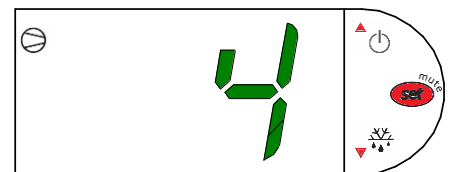
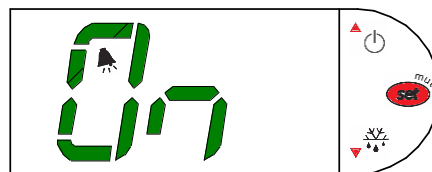

### Powering on control

To turn refrigeration control power on, press and hold  for approx. five seconds. The display will read “On” while the button is depressed. When the control powers on, the display will read the control set point of 1 thru 9. The compressor run indicator  will illuminate on the display, meaning that the compressor is running. (Note: the control may already be in the on mode when shipped from factory).

To turn refrigeration control power to off, press and hold  for approx. five seconds. The display will read “Off” while the button is depressed. When the control powers off the display will flash back and forth between the control set point and “Off”. The compressor run indicator  will be off on the display. When refrigeration control is in the off- mode cabinet lights and evaporator fans will still operate, but the compressor will not turn on causing the case to gradually reach room temperature.





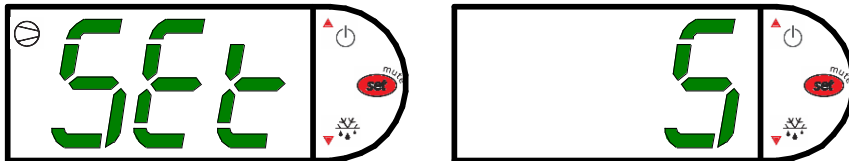

## Adjusting the set point

The setpoint is what determines how cold the display case will hold food and beverage. To adjust the setpoint press and hold the  button approx. 5 seconds until the display begins to flash the set point number. Then press the use the  button to scroll number up (colder) or press the  button to scroll number lower (warmer). There are nine (9) available setpoints numbers, the higher the number of the setpoint, the colder the display case will run, with setting “9” being the coldest and setting “1” being the warmest. Once you have chosen your desired setting press the  button again to confirm your choice.



## Entering manual defrost mode

To initiate a manual, defrost press and hold the  button approx. 5 seconds. The control will read “dEF” while the button is being held. The defrost is initiated when the defrost mode indicator  illuminates on the display. The control display will then return to reading the set point. When the defrost mode indicator  turns off the defrost is complete and the compressor will turn back on illuminating the compressor run indicator .



## Error codes

It is possible for error codes to be displayed on the control screen. In the event of a malfunction an alarm will sound and the alarm indicator  will be displayed on the display. An error code or codes will flash intermittently on the display. If there are multiple codes, the display will continuously cycle through them. The following photo shows error code “E0” as an example.



**Mute:** You may mute the alarm by pressing and releasing the wrench button. The red ringing bell and all error codes will still be displayed. When the fault is remedied the control will return to normal operation and will automatically clear the codes from the display.

Error codes may be encountered if either the controller or the display case is malfunctioning. The following is a list of error codes that may be encountered.

## Error Codes and Resolutions

Code	Description	Cause	Resolution
E0	Temperature probe error	Probe signal is interrupted or short-circuited	1. Check to ensure probe wires and quick disconnect are secure in control.
E1	Defrost probe error	See E0	2. Check probe resistance to table below. If 0 resistance is present check wiring insulation. If infinite resistance is present check for breaks in wiring (meter will likely read overload or very high in the mega-ohm range). 3. Ensure that probes are wired per the wiring diagram provided. 4. Replace probe if other remedies fail, or if probe resistance deviates from <b>“Error! Reference source not found.” Error! Reference source not found.</b>
EE	Unit parameter reading error	Operating conditions	1. Remedy abnormal operating conditions. The control is rated to operate in a range of 14 to 122°F (-10 to 50°C) and less than 90%RH non-condensing.
EF	Operating parameter reading error	See EE	2. Replace control if problem persists.

## Temperature Probe Common Resistance Chart

Probe Temp	Maximum Resistance [Ω]	Normal Resistance [Ω]	Minimum Resistance [Ω]
32°F (0°C)	27.83	27.28	26.74
77°F (25°C)	10.1	10	9.9
212°F (100°C)	1	0.97	0.94

## **REFRIGERANT DETECTION AND MITIGATION SYSTEM**

The refrigerant detection system (RDS) shuts down the operation of the refrigerator when a leak is detected. The system is comprised of 2 or more sensors, a low voltage power supply, 1-2 safety shutoff solenoid valves, and 1-2 refrigerant check valves.

When a leak is detected by one of the sensors, the internal sensor relay opens to shut off the safety solenoid valve(s). The refrigeration check valve prevents any back flow from the rest of the external system from entering the unit that would further contribute to a leak.

The sensor is equipped with an LED status light, indicating the Refrigerant Detection System's status, as shown below:



Please note that once a leak is detected and the flow of refrigerant is stopped, the display case will stop cooling, and any temperature sensitive products must be removed from the unit.

This display case's fans are a part of the leak mitigation system and are required to remain powered on as long as there is power to the display case. In the event of a refrigerant leak, the unit's fans are required to run to reduce the concentration of flammable refrigerant in and around the unit. When replacing gas detection sensors, only replace with the original model of sensor provided by Federal.

To replace a faulty sensor, simply remove unplug the electrical quick connection and unscrew the sensor fasteners and attach the new sensor to the original sensor location in the original orientation.

After replacing installing the new sensor, power on the display case. After a few seconds, the sensor light will begin to blink green. See illustration above. The refrigeration system will be allowed to run as normal.

The sensor is capable of a long life and will monitor its condition to ensure functionality. If the sensor's self-monitoring system detects an issue it will go into a fault state and shut off the flow of refrigerant to the appliance. See above illustration for fault indication on LED.

The gas inlet exposes the sensing element of the sensor to surrounding gases. The opening in the sensor housing exposes the humidity and temperature sensors inside the sensor to the environment and makes them susceptible to pollutants such as volatile chemicals, acids, bases, cleaning and foaming agents. Exposure to those pollutants should be avoided. Cleaning products might damage the sensor or temporarily block its gas inlet, inhibiting or delaying the response to the refrigerant.

The use of solvent emitting materials near the sensor, such as PVC cement glues, may lead to nuisance trips. Solvent emitting materials can lead to high concentrations of volatile gas in the nearby environment. The gas sensor may sense these concentrations, and trigger a system mitigate response. Please note that the safety shut-off valve system is installed at the factory. No safety shut-off valves are required to be installed in the field on new equipment.

**Refrigerant Detection System (RDS) Location**

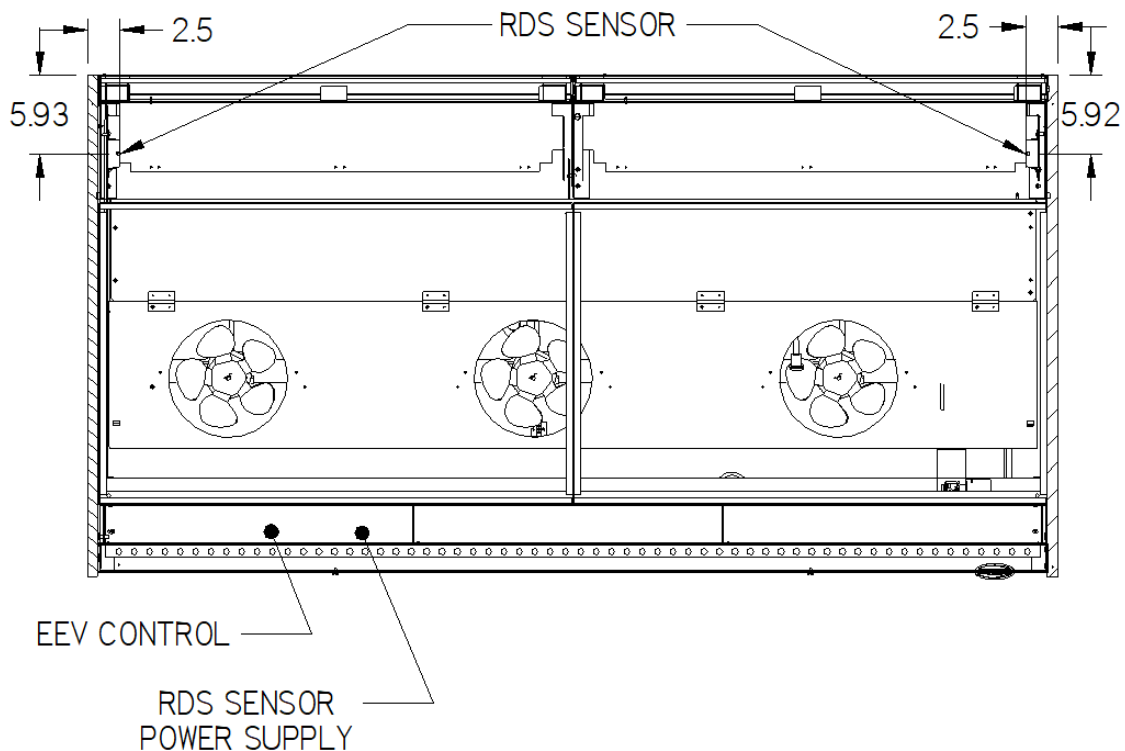
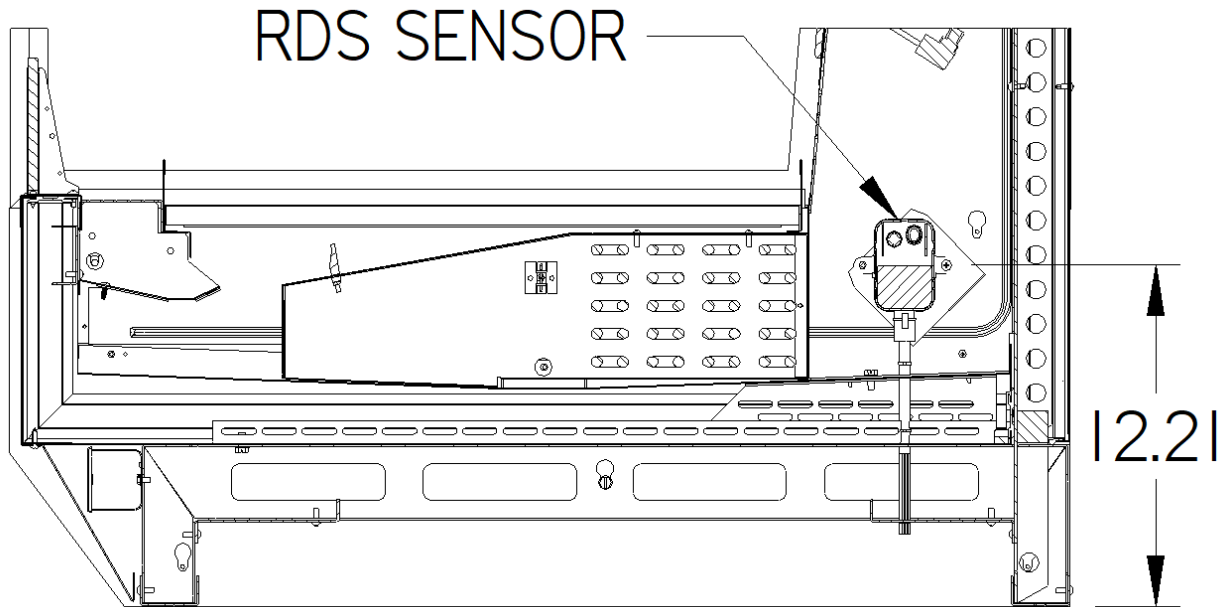

## **NIGHT CURTAIN OPERATION**

Night curtains are standard on all LMD models. They are provided to conserve energy when case is not being used.

**NOTE:** When using optional Security Cover the Night Curtain(s) must be closed.

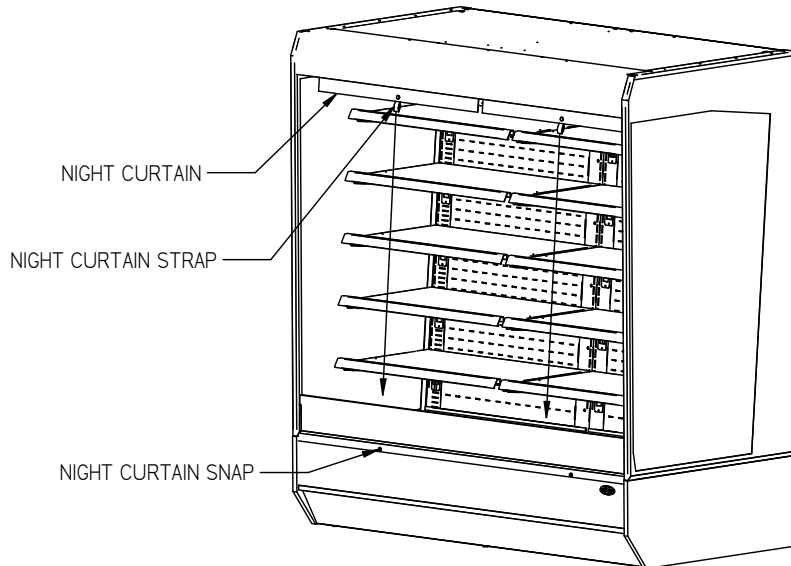

### **OPENING:**

1. Grab night curtain strap located behind the top valance. Pull the night curtain down the front of case opening.
2. Attach the snap located under the night curtain strap on to the snap located on the front trim.

### **CLOSING:**

1. Grab the night curtain strap and detach the snap from the snap located on the front trim.
2. While holding the night curtain strap allow the night curtain to roll up.

**Note:** The LMD72 AND LMD96 models have (2) night curtains.

## **SECURITY COVER OPERATION (OPTIONAL)**

Security Covers are optional on all LMD models. They are provided to cover product and allow case to run while unattended.

**NOTE: When using optional Security Cover the Night Curtain(s) must be closed.**

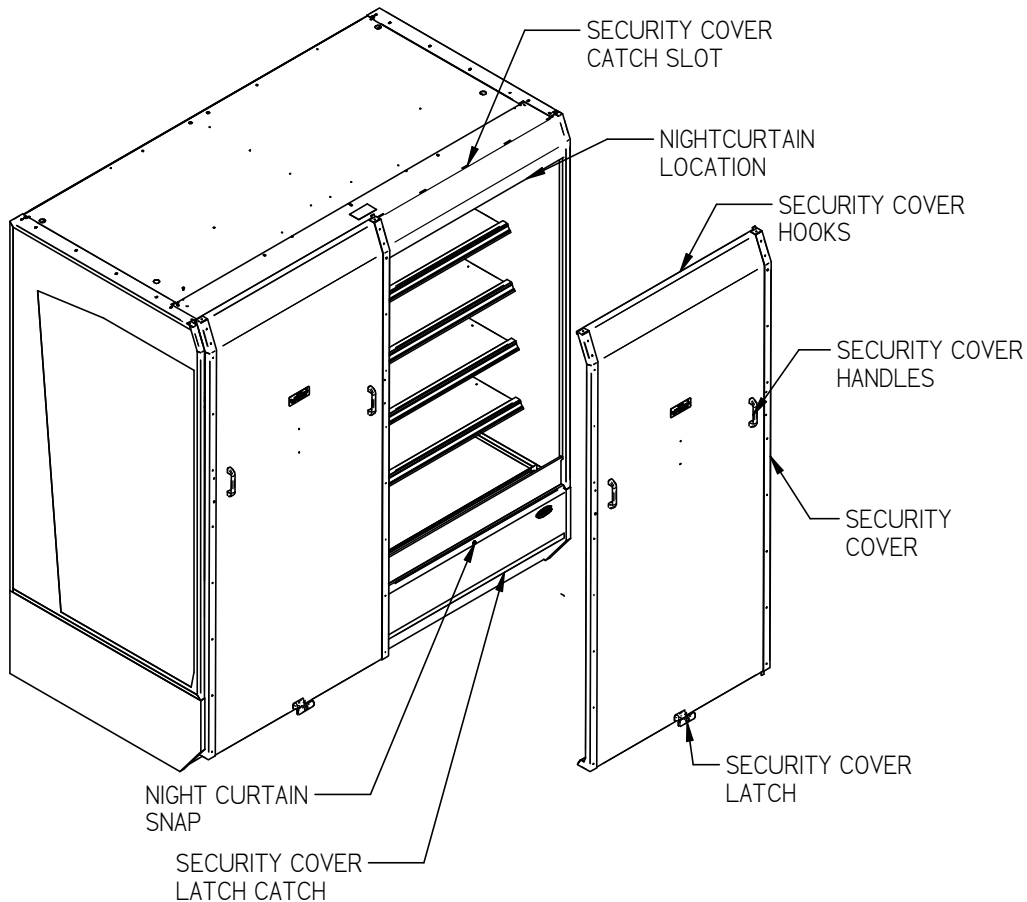

### **REMOVING**

1. Use key provided to unlock Latch.
2. Turn Security Cover Latch vertical to unhook it from Security Cover Latch Catch.
3. Grab Security Cover Handles and lift Security Cover up so the Security Cover Hooks lift out of the Security Cover Catch Slots.

### **INSTALLING:**

1. Close Night Curtain(s) as described in previous section. **IMPORTANT:** Night Curtain must be closed or condensation will form on front of Security Cover.
2. Grab Security Cover Handles and lift it up so the Security Cover Hooks slide down into the Security Cover Catch Slots located on top of case canopy.
3. Push in on bottom of Security Cover and turn Security Cover Latch Horizontal to hook behind Security Cover Latch Catch.
4. Use key provided to lock Latch in horizontal position.

**Note:** The LMD72 AND LMD96 models have (2) security covers.

---

---

## H) INITIAL START-UP

---

---

After all the checks outlined in the installation section of this manual have been made, the case is ready to be put into service. Turn on the Power at the breaker box and flip the Power Switch and Light Switch on unit to the on position.

At start up from a warm unit, it is recommended that the temperature control is set at a warm setting, such as 1 on the dial. After the unit has gone through several cycles, turn the control to a mid-range setting, then to a colder setting if necessary to maintain desired product temperature



**NOTICE: This refrigerated display case is designed to operate in a maximum environment of 80° F and 55% relative humidity. Exceeding these limits will cause poor case performance and excessive sweating.**

### **PLACING PRODUCT INTO CASE**

- Do not exceed 100 pounds of weight per shelf. Heavy product should be distributed evenly across the entire shelving area.
- Determine desired shelving location before placing product in case. Product must be removed to readjust shelf location.
- Allow a minimum of 2” between top of product and bottom of shelf.
- Do not overhang the front or rear of shelves with product. Improper clearance in front and rear of shelf will block the refrigerated airflow and will cause product loss.
- Do not block the slots along the front and rear air discharge slots. Covering these slots will block the refrigerated airflow and could cause product loss.
- The display deck is removable for cleaning and can become dislodged in shipment. To ensure proper airflow and performance of the case, make sure that the display deck is pushed completely down.
- Allow refrigerated models to run for at least two hours before placing pre-chilled product into unit.



**NOTICE: CASE MUST BE STOCKED WITH PRE-CHILLED PRODUCT**

**38° OR COLDER.**



**NOTICE: This refrigerated display case is designed to operate in a maximum environment of 80° F and 55% relative humidity. Exceeding these limits will cause poor case performance and sweating of glass panels.**

---

---

## I) MAINTENANCE

---

---

### **TOP LIGHT BULB REPLACEMENT**

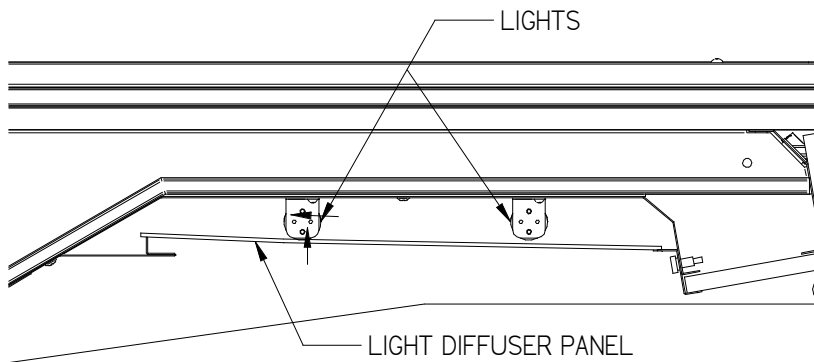

There are (2) top lights on the LMD4878 & LMD7278 and there are (4) on the LMD9678. To access these lights, the top light diffuser must be removed.

1. Remove the top shelf or shelves from the case.
2. Push up on the back of the Light Diffuser Panel and slide it back over The lip on the rear retainer until the front drops down of the front retainer.
3. Once light diffuser is removed the lights can be removed.  
**-LED Strip Light:** Led can be removed by unplugging cord from end of led and then unsnapping lights from the light clip. Replace LED light in reverse order
4. Reinstall light diffuser.

### **CLEANING CONDENSER COIL**



**NOTICE:**

**Condenser coil must be cleaned a minimum of twice per month to insure proper refrigeration performance and prevent compressor failure. In some environments, it may be necessary to clean more frequently. FAILURE TO CLEAN CONDENSER COIL WILL VOID COMPRESSOR WARRANTY.**

The condenser coil is remotely mounted in another location, but it is very important that the Condenser coil is cleaned twice per month to insure proper refrigeration performance and to prevent compressor failure. Failure to clean condenser coil will void condenser warranty.

1. Find the remote mounted Condensing unit
2. Disconnect power to the unit.
3. Carefully vacuum the front surface of condenser coil. Take care not to bend coil fins with vacuum cleaner nozzle.

---

---

## J) CLEANING INSTRUCTIONS

---

---

### **DAILY CLEANING**

The case should be cleaned thoroughly, as described in the weekly cleaning section, before it is used for the first time.



**NOTICE:**

**Avoid splashing or soaking any electrical components with water to prevent electrical damage to the case.**



**NOTICE:**

**Shut off lights, disconnect power and remove all products from case. Allow sufficient time for the unit to reach room temperature before proceeding with cleaning.**



**NOTICE:**

**Remove all products from the case before proceeding with cleaning procedure.**



**NOTICE:**

**Acrylic air deflector requires special washing procedures to prevent hazing and yellowing of material. Clean as described in “Acrylic Air Deflector Cleaning” section of this manual.**

**Note:** For major spills or foreign material buildup use complete weekly cleaning instructions.

**Note:** Detergents are not recommended and do not use abrasive cleaners or pads to prevent scratching of surfaces.

1. Dip rag in warm soapy water and ring out thoroughly. Wipe complete interior of case and dry with soft dry towel.
2. The remaining exterior surface should be wiped down using any ammoniated cleaners or soapy warm water and dried with soft dry towel.
3. **IMPORTANT:** Cleaning the clear acrylic plastic front air deflector requires special care to prevent hazing and yellowing of material. Clean as described in “Acrylic Air Deflector Cleaning” section of this manual.



**NEVER USE** paper towels (wet or dry) for cleaning or drying and never use a dry towel.

**NEVER USE** glass cleaner of any kind.

Lightly dust (not wipe) surface with a damp Micro Fiber towel or chamois. The surface can then be washed using a small amount of dishwashing detergent such as Dawn or Joy and lukewarm water. Use a Micro Fiber towel or chamois, applying only light pressure. The cloth or chamois must be kept free of grit by frequently rinsing. Rinse surface with clear water and dry by blotting with a damp Micro Fiber towel or chamois.

## Weekly Cleaning



### NOTICE:

Shut off lights and disconnect power and remove all products from case. Allow sufficient time for the unit to reach room temperature before proceeding with cleaning.



### NOTICE:

Avoid splashing or soaking any electrical components with water to prevent electrical damage to the case.



### NOTICE:

Remove all products from case before proceeding with cleaning procedure.



### NOTICE:

Acrylic front air deflector requires special washing procedures to prevent hazing and yellowing of material.

**Note:** Detergents are not recommended and do not use abrasive cleaners or pads to prevent scratching of surfaces.

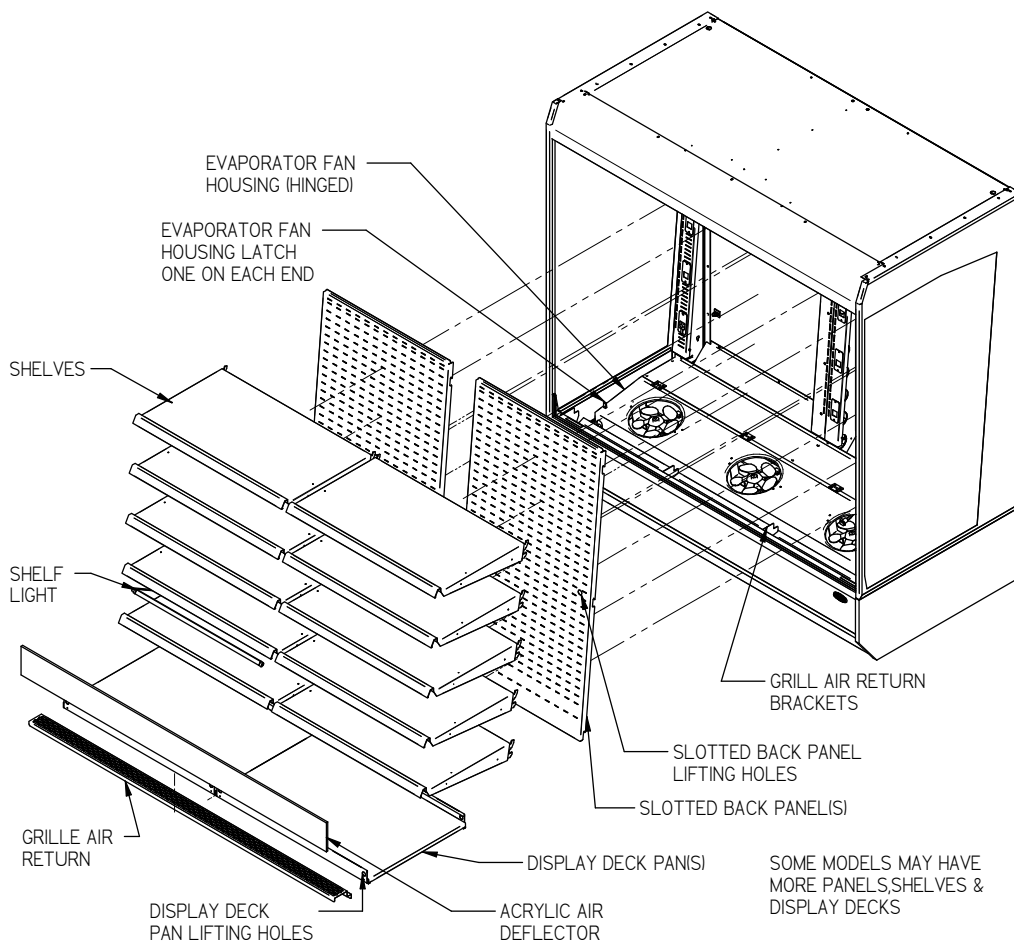

1. Remove the Acrylic Air Deflector by lifting it up and out of Air Deflector Retainer. Clean as described:



**IMPORTANT: Cleaning the clear acrylic plastic front air deflector requires special care to prevent hazing and yellowing of material. Clean as described in “Acrylic Air Deflector Cleaning” section of this manual.**

**NEVER USE** paper towels (wet or dry) for cleaning or drying and never use a dry towel.

**NEVER USE** glass cleaner of any kind.

Lightly dust (not wipe) surface with a damp Micro Fiber towel or chamois. The surface can then be washed using a small amount of dishwashing detergent such as Dawn or Joy and lukewarm water. Use a Micro Fiber towel or chamois, applying only light pressure. The cloth or chamois must be kept free of grit by frequently rinsing. Rinse surface with clear water and dry by blotting with a damp Micro Fiber towel or chamois.

2. Remove interior Shelves and Shelf Lights from unit as described in the “Shelving Installation” section of this manual.
3. Remove the Display Deck Pan(s) from unit by grabbing the lifting holes located on front lip of Display Deck Pan(s) and lifting them up and out of unit.
4. Remove the Grill Air Return by lifting it up and off the Grill Air Return Brackets.
5. Remove the Slotted Back Panel(s) from unit. Lift the Slotted Back Panel up until the bottom of panel clears the evaporator cover and then swing the bottom of the Slotted Back Panel out until the top of panel clears the top light housing flange.
6. Dip rag in warm soapy water and ring out thoroughly. Clean all shelves, Display Deck(s), Grill Air Return and Slotted Back Panel(s) and dry with soft dry towel.
7. Clean the entire interior of the case using warm soapy water. Wipe off all soapy water with a damp cloth and allow to dry. (DO NOT use solvents such as Acetone, Benzene, Carbon Tetrachloride, and Lacquer Thinners)  
Clean under the Evaporator Fan Housing and Drain area by lifting (2) Evaporator Fan Housing latch levers up and swinging the hinged Evaporator Fan Housing up and out of the way.
8. Remove the honeycomb air diffuser(s) from upper air duct track. Loosen thumb screws on Retainer located behind diffuser. Retainer will drop down allowing diffuser to be pulled out of case.

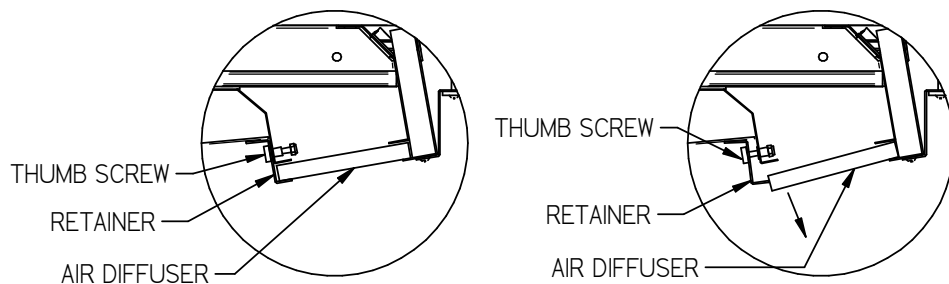

9. Clean honeycomb air diffuser with warm soapy water and a brush. Rinse thoroughly and allow it to dry.
10. Reassemble all components in reverse order.

NOTE: Depending on the amount of usage and spillage of foreign material, some fasteners may have to be removed, and parts disassembled to allow proper cleaning of the unit.

---

---

## K) SERVICE INFORMATION

---

---

**CAUTION**

RISK OF ELECTRIC SHOCK

DISCONNECT POWER  
BEFORE SERVICING UNIT

**Before any service work is performed on the case, make sure all power is disconnected to the case.**

To find a service company in your area, please visit our website at [www.federalindustries.com](http://www.federalindustries.com). There you can also find self-service tools to help you get the answers you need faster!

For Warranty Service Requests & ALL Technical Support please contact:

- Phone: (800) 356-4206 and choose the Tech Support/Warranty Option
- Email: [Service@federalind.com](mailto:Service@federalind.com)

For Warranty Compressors please contact the Parts Department:

- Phone: (800) 356-4206 and choose the Warranty Parts Option
- Email: [Parts@Federalind.com](mailto:Parts@Federalind.com)



Federal Industries has partnered with Parts Town for ALL Non-Warranty Part Identification, Pricing, Lead Times, Orders & Freight Quotes. Please contact Parts Town directly if you need parts:

- Website: [PartsTown.com](http://PartsTown.com)
- Email: [CustomerService@PartsTown.com](mailto:CustomerService@PartsTown.com)
- Phone: 833-809-8188

## **SPECIAL SERVICE SITUATIONS**

There are rare occasions when the refrigerant charge must be evacuated from a case in order to perform service work. In those situations, Federal Industries recommends that the refrigerant charge be evacuated into a recovery system to prevent the possibility of hydrofluorocarbons (HFC's) from being released into the atmosphere.

If moisture or liquid is observed around or under a Federal Industries case, an immediate investigation should be made by qualified personnel to determine the source of the moisture or liquid. The investigation made should determine if the case is malfunctioning or if there is a simple housekeeping problem.



### **NOTICE:**

**Moisture or liquid around or under a case is a potential slip/fall hazard for persons walking by or working in the general area of the case. Any case malfunction or housekeeping problem that creates a slip/fall hazard around or under a case should be corrected immediately.**

## **PRE-SERVICE CHECKLIST**

You may avoid the cost and inconvenience of an unnecessary service call by first reviewing this checklist of frequently encountered situations that can cause unsatisfactory case performance.



**CAUTION: Before servicing case, turn off power at the main breaker of fuse box.**

### ***Case Does Not Operate***

- Check for disconnected power supply.
- Check for tripped breaker on blown fuse.
- Check that the thermostat display is on and that the green indicator light is lit.

### ***Lights Do Not Operate***

- Check that light switch is on.
- Check for tripped breaker or blown fuse.
- Check that light housing cords are plugged in correctly to sockets in the tower

### ***Case Temperature Too Warm***

- Check that the cold air inlet and outlet slots are not blocked.
- Check for a blocked or dirty condenser coil.
- Check for cold airflow. Lack of adequate cold airflow could indicate a defective evaporator fan or a blocked evaporator coil. Check that paper or foreign materials are not blocking evaporator. If the evaporator coil is blocked due to excessive frost, put into manual defrost. Excessive frost can buildup overtime if the case is set too cold or if there is excessive humidity in the store.
- Check all the fans in the evaporator compartment and tower are running.

### ***Case Sweating Note:*** Some interior sweating is normal on this case.

- Check room ambient – Case is designed to operate in an environment not to exceed 75°F and 55% relative humidity.
- Check all the fans in the evaporator compartment are running.

### ***Overflow of Condensate Pan***

- Check that drain in bottom of tub floor is not plugged.
- Check that drain trap to the condensate pan is not plugged

### ***Overflow of Optional Condensate Pump:***

- Check that drain in bottom of tub floor is not plugged.
- Check that drain trap to the condensate pan is not plugged
- Check that drain lines from pump is not plugged or pinched.
- Check to see that pump float is operating correctly.
- Verify that pump is plugged in and has power.
- Replace pump if still not pumping condensate.

---

---

## L) SALE & DISPOSAL

---

---

If you the owner sells or gives away this Federal Industries case it is the owner's responsibility to make sure that all safety labels and the Installation-Service Manual are included with it. If you need replacement labels or manuals, Federal Industries will provide them free of charge. Contact the customer service department at Federal Industries at (800) 356-4206.

The customer service department at Federal Industries should be contacted at the time of sale or disposal of your case so records may be kept of its new location.

If you sell or give away your Federal Industries case, you should evacuate the refrigerant charge before shipment. Federal Industries recommends that the charge be evacuated into a recovery system to prevent the possibility of HCFC's from being released into the atmosphere.

## M) REFRIGERATION OPERATION

Refrigeration R454C Charge	CHARGED IN FIELD
Remote Low Press. Switch Cut In	40 psi
Remote Low Press. Switch Cut Out	15 psi
Adjustable Head Master	200 psi
Remote High Press. Switch Cut Out	400 psi

The remote models are designed to use R454C refrigerant and shipped from the factory with the evaporator coil, expansion valve, and refrigerant solenoid valve. Drier filter must be installed in field for proper operation. Electronic control opens and closes a refrigeration solenoid valve located on the suction line and shuts off the refrigeration flow to the unit and initiates a pump down cycle. This will allow the remote low-pressure switch to open and shut off remote compressor.

The condensing unit and pressure controls are optionally supplied from the factory for remote location installation. The condensing unit must be mounted and wired by the installer. The high low-pressure switch must be wired in series with the compressor power supply as shown in diagram below.

1. Mount condensing unit indoors as close to the remote display case as practical. The refrigeration line should be as short as possible and must not exceed 30 feet.
2. All refrigeration and/or electrical materials between the condensing unit and display case are to be supplied by installing contractor.
3. Route properly sized and designed refrigeration lines from the condensing unit to the cabinet. Horizontal suction lines should be pitched downward towards the condensing unit at least ½” per 10’ run to aid the oil drainage. A “P” trap must be installed in the suction line at the foot of every riser to insure oil return. Dry nitrogen must be used to flow through tubing while brazing refrigeration lines.
4. Suction line must be insulated the entire length with Armaflex (or equivalent). Do not run liquid line inside insulation with suction line.
5. The remote high/low-pressure control must be installed and set pressures by the installer.
6. Leak check condensing unit, cabinet, and all connecting tubing. Cabinet and condensing unit tubing should be checked to insure no leaks occurred during shipping or from rough handling. Make certain all refrigeration valves are opened and evacuate system to 500 microns. Charge the system with refrigerant type specified on the data plates.

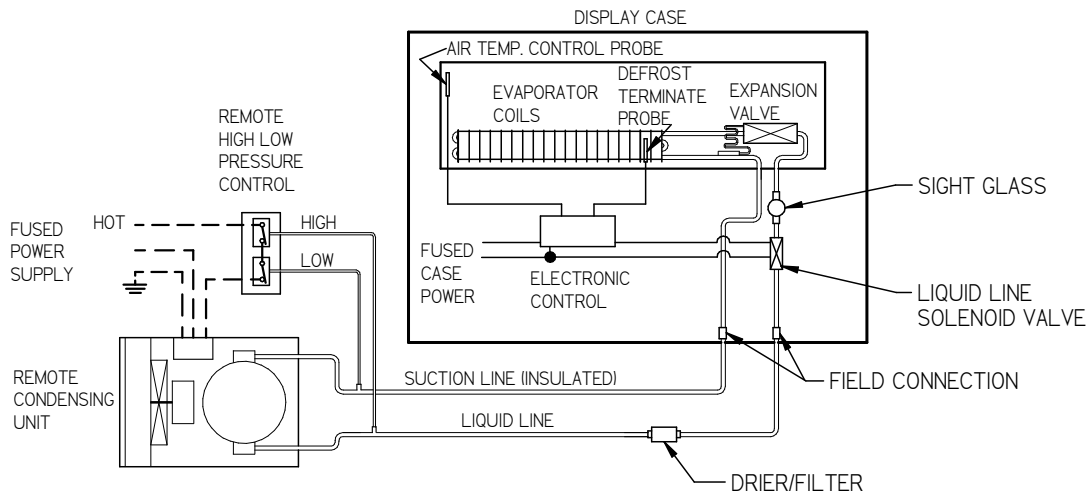

## **ELECTRONIC EXPANSION VALVE (EEV)**

A traditional TXV uses springs and a temperature bulb to open and close a valve port that controls the flow of refrigerant entering the evaporator coil. An electronic expansion valve (EEV) controls the refrigerant flow much more precisely, increasing the performance and efficiency of the refrigeration system. The EEV controls the flow of Refrigerant by opening and closing the valve port based on the response to signals sent to the EEV by an electronic controller. The electronic Control bases these signals by processing information provided from a temperature sensor and pressure transducer located on the discharge side of the evaporator coil.

These sensors monitor the evaporator superheat and protects the compressor from any liquid flood back under low superheat conditions.

## **EEV CONTROLLER SETTINGS**

The electronic expansion valve controller also allows the use of different types of refrigerants without the need to change the expansion valve.

The controller is set from the factory to run on 454C refrigerant (code 54C) and will not need to be changed unless another refrigerant is used.

NOTE: On units with older model EEV's, the EEV is set to code 40C

**Note: Check your State and Local regulations for approved refrigerants for your install location. Federal Industries is not liable for any alternate refrigerants used.**





The control is located in the front left corner of evaporator tub under the Display Deck Pan.

**Note: Never change any of the other setting other than the refrigerant type. It may also be necessary to change the superheat setting only when using a different refrigerant.**







Indicator lights	
	Red light - critical alarm (system is NOT running)
	Yellow light - non-critical alarm (system running)
	Green light - compressor on
	Green blinking - compressor waiting on timer to start/stop

### Changing Refrigerant

- Access the set point mode by pressing and holding the **ENTER** button until Ctl displays on the screen.
- Use the  up or  down arrows to advance through the available set points until rFG displays on the screen and press the **ENTER** button.
- Use the  up or  down arrows until the desired refrigeration displays on the screen and press and hold the **ENTER** button until rFG once again displays on the screen.
- Press the **BACK** to return to escape the settings menu.

### Changing Superheat

- Access the set point mode by pressing and holding the **ENTER** button until Ctl displays on the screen.
- Use the  up or  down arrows to advance through the available set points until SSP displays on the screen and press the **ENTER** button.
- Use the  up or  down arrows to set the desired superheat displays on the screen and press and hold the **ENTER** button until SSP once again displays on the screen.
- Press the **BACK** to return to escape the settings menu.

## N) PARTS LIST

	ELECTRICAL COMPONENTS					
	LMD4878R		LMD7278R		LMD9678R	
	QTY	PART#	QTY	PART#	QTY	PART#
CAREL TEMP. CONT. 115V	1	32-19864-12	1	32-19864-12	1	32-19864-12
TEMPERATURE PROBE	2	32-19866	2	32-19866	2	32-19866
SWITCH,ROCKER 22A	1	41-11066	1	41-11066	1	41-11066
RECEPTACLE,WHITE	5	43-19080-A	10	43-19080-A	10	43-19080-A
PLATE,RECEPT SHELF LIGHT WHITE	5	M-10167-2B	10	M-10167-2B	10	M-10167-2B
POWER SUPPLY 24V	2	39-20555	2	39-20555	3	39-20555
LED CEILING, 24V 35k	2	42-20871-42C35	2	42-20871-72C35	4	42-20871-42C35
CORD CEILING LED WHITE	2	43-20867-8W	2	43-20867-8W	4	43-20867-8W
LED, 24V 35k	6	42-20871-42C35	12	42-20871-30C35	12	42-20871-42C35
CORD,SHELF LED WHITE	5	43-20862-6W	10	43-20862-6W	10	43-20862-6W
CORD,TOP LED WHITE	1	43-20868-3W	2	43-20868-3W	2	43-20868-3W
HARNESS,5 LIGHT	1	43-20147	2	43-20147	2	43-20147

	REFRIGERATION COMPONENTS					
	QTY	PART#	QTY	PART#	QTY	PART#
MOTOR,FAN 115V. 60Hz,	2	41-17981	3	41-17981	4	41-17981
BLADE,8" 5 BLADE, 15D SUCT	2	72-32507	3	72-14569	4	72-32507
HARNESSWIRE,DOUBLE FAN	1	43-19749	2	43-19749	3	43-19749
EEV, RSV-130 3/8X1/2ODF	1	32-21226	1	32-21226	2	32-21226
EEV CONTROL	1	32-21223	1	32-21223	2	32-21223
TEMP. SENSOR EEV	1	32-21224	1	32-21224	2	32-21224
PRESSURE TRANSDUCER	1	32-21225	1	32-21225	2	32-21225
COIL,EVAP MULTI DECK	1	33-20026-1	1	33-20026-2	1	33-20026-23
VALVE, ACCESS 5/8 COPPER	1	82-14323	1	82-14323	2	82-14323
SOLENOID VALVE	1	32-21915-6	1	32-21915-6	1	32-21915-6
COIL,SOLENOID 24V	1	39-21915-C24	1	39-21915-C24	1	39-21915-C24
SWELL LATCH	2	66-13640	2	66-13640	2	66-13640
HINGE,PLASTIC	3	66-14094	4	66-14094	5	66-14094

	MISC COMPONENTS					
PANEL,END GLASS	2	50-20029	2	50-20029	2	50-20029
PANEL,END GLASS REFLECTIVE LEFT	1	50-20029-1L	1	50-20029-1L	1	50-20029-1L
PANEL,END GLASS REFLECTIVE RIGHT	1	50-20029-1R	1	50-20029-1R	1	50-20029-1R
PANEL,LAMINATE FRONT (COLOR REQD)	1	W11732-1	1	W11732-2	1	W11732-3
PANEL,END LAM (COLOR REQD)	1	68-20042-L	1	68-20042-L	1	68-20042-L
PANEL,END LAM (COLOR REQD)	1	68-20042-R	1	68-20042-R	1	68-20042-R
LEG,1/2-13 X 2.5	4	65-11486	6	65-11486	6	65-11486
CASTER,2-1/2"	4	65-17352	6	65-17352	6	65-17352
ECONO COVER,56" DBL ACTION WHITE	1	65-19464	3	65-19462	2	65-19464
AIR DIFFUSER	2	W11724-1	2	W11724-2	2	W11724-3
THERMOPLASTIC DRAIN	1	84-70225	1	84-70225	2	84-70225
DRAIN ASSY,TUBE	1	SA5522	1	SA5522	1	SA5523
TUBING,3/4 ID CLEAR PVC	25'	15-19609	25'	15-19609	25'	15-19609
SHELF,WELD WHITE	5	SA5458-1	10	SA5458-2	10	SA5458-1
THERMOMETER	1	32-13662	1	32-13662	1	32-13662
DEFLECTOR,AIR FRONT	1	15-20030-1	1	15-20030-2	1	15-20030-2
NIGHT CURTAIN	1	65-19464	2	65-19462	2	65-19464
SECURITY COVER (OPTION) NAT ALUM	1	SA5658-1B	2	SA5658-2B	2	SA5658-1B
SECURITY COVER (OPTION) BLACK TEXT	1	SA5658-1	2	SA5658-2	2	SA5658-1
DECAL,CATION ELECTRICAL SHOCK	2	91-12340	2	91-12340	2	91-12340
LOGO,FEDERAL	1	91-72523	1	91-72523	1	91-72523

# O) CASE WIRING DIAGRAMS

LMD48, 72, 96

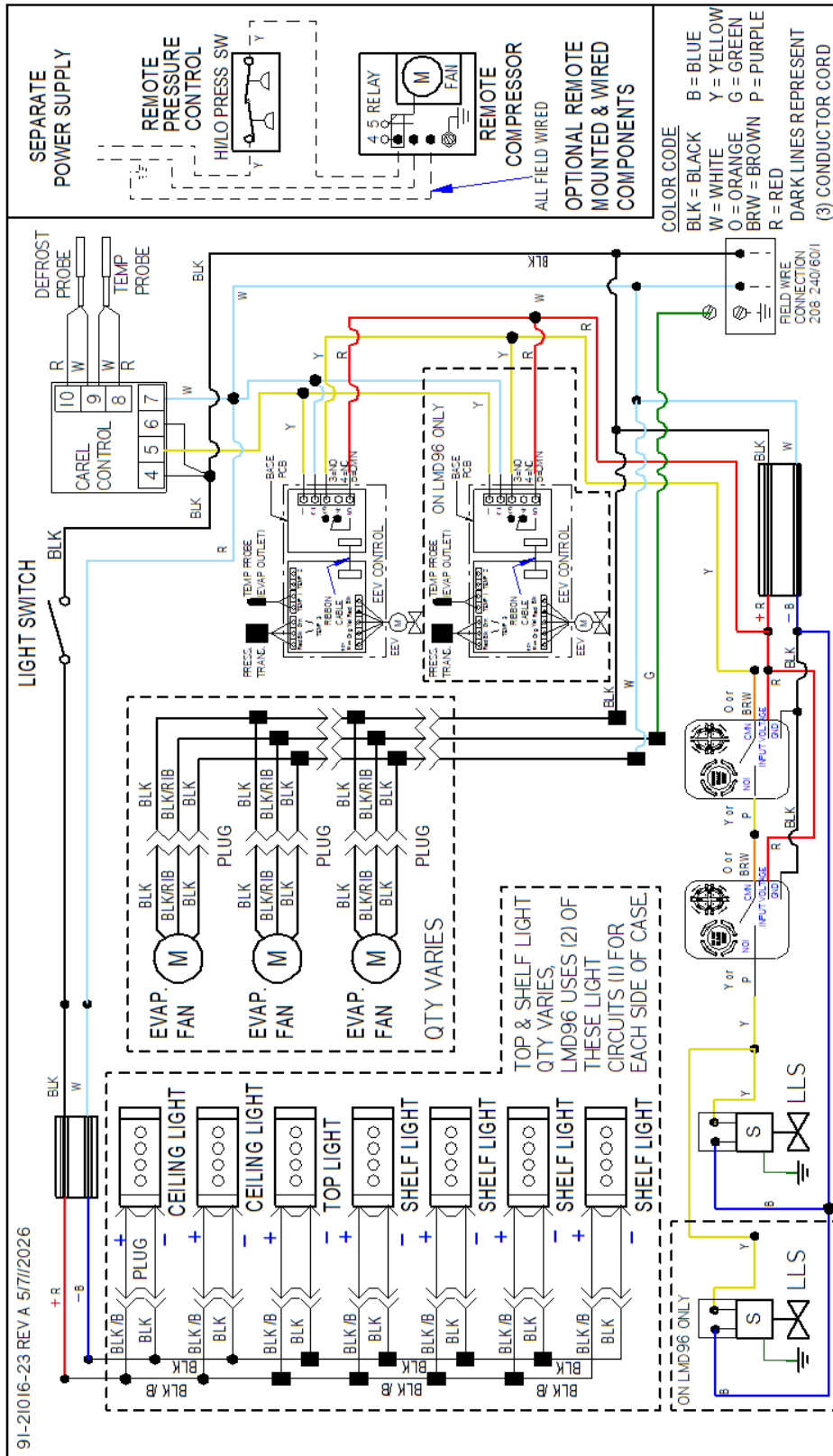

**California Residents Only.**

**WARNING**

**This product can expose you to chemicals including chromium which is known to the State of California to cause cancer and birth defects or other reproductive harm. For more information go to [www.P65Warnings.ca.gov](http://www.P65Warnings.ca.gov)**

